



DLP TV

Chassis : L64C(N_VE Model)_Hurricane-2
Basic Model : HLR5067WX/XAA (HL-R5067W)
Model : HLR4667W1X/XAA (HL-R4667W)
HLR5067W1X/XAA (HL-R5067W)
HLR5667W1X/XAA (HL-R5667W)
HLR6167W1X/XAA (HL-R6167W)

SERVICE Manual

DLP TV



HL-R5067W

FEATURES

- HD Built in TV
- NTSC/ATSC Tuner Embedded
- AV network system (Anynet, D-Net)
- TV Guide On Screen™ system (Gemstar EPG)
- Digital Audio output (OPTICAL) jack
- Cable CARD™ slot
- Firmware upgrade by USB Port



ELECTRONICS

This Service Manual is a property of Samsung Electronics Co.,Ltd.
Any unauthorized use of Manual can be punished under applicable
International and/or domestic law.

© Samsung Electronics Co., Ltd. **Jul. 2005**
Printed in Korea
AA82-02823A

Table of Contents

Chapter 1 Precaution

■ 1-1 Safety Precautions	1-1
■ 1-2 Servicing Precautions	1-3
■ 1-3 Static Electricity Precautions	1-4
■ 1-4 Installation Precautions	1-5

Chapter 2 Product Specification

■ 2-1 Product Features	2-1
■ 2-2 Key Features	2-2
■ 2-3 Specifications Analysis	2-4
■ 2-4 Accessories	2-5

Chapter 3 Alignment & Adjustment

■ 3-1 Service Instruction	3-1
■ 3-2 How to Access Service Mode	3-2
■ 3-3 Factory Data	3-3
■ 3-4 Service Adjustment	3-13
■ 3-5 Software Upgrade	3-16
■ 3-6 Replacements & Calibration	3-17

Chapter 4 Exploded View & Part List

■ 4-1 HLR4667W1X/XAA	4-1
■ 4-2 HLR5067W1X/XAA	4-2
■ 4-3 HLR5667W1X/XAA	4-3
■ 4-4 HLR6167W1X/XAA	4-4
■ 4-5 L620 Engine Ass'y	4-5

Chapter 5 Electrical Part List

■ 5-1 HLR4667W1X/XAA Service Item	5-1
■ 5-2 HLR5067W1X/XAA Service Item	5-2
■ 5-3 HLR5667W1X/XAA Service Item	5-3
■ 5-4 HLR6167W1X/XAA Service Item	5-4

Chapter 6 Troubleshooting

■ 6-1 Checkpoints by Error Mode	6-1
■ 6-2 Troubleshooting Procedures by Error Modes	6-7
■ 6-3 Troubleshooting Procedures by ASS'Y	6-9

Chapter 7 Block Diagram

■ 7-1 Overall Block Diagram	7-1
■ 7-2 Partial Block Diagram	7-2

Chapter 8 Wiring Diagram

■ 8-1 Overall Wiring	8-1
■ 8-2 Connection between Analog and Digital Board	8-2

Chapter 9 PCB Diagram

■ 9-1 Power Board	9-1
■ 9-2 Digital Board	9-3
■ 9-3 Analog Board	9-6
■ 9-4 DMD Board	9-10

Chapter 10 Schematic Diagram

■ 10-1 Analog Board	10-1
■ 10-2 Digital Board	10-10
■ 10-3 DMD Board	10-28
■ 10-4 Actuator Board	10-35
■ 10-5 Ballast	10-36
■ 10-6 Power Board	10-37
■ 10-7 Combined Bridge and Control Module	10-38
■ 10-8 Detect	10-39
■ 10-9 Side-AV	10-40
■ 10-10 Key Control	10-40
■ 10-11 RMC-LED	10-40

Chapter 11 Operation Instruction & Installation

■ 11-1 Product Features and Functions	11-1
■ 11-2 New Features	11-5

Chapter 12 Disassembly & Reassembly

■ 12-1 Overall Disassembly & Reassembly	12-1
---	------

Chapter 13 Circuit Description

■ 13-1 Overall Block Description	13-1
■ 13-2 Partial Block Description	13-2
■ 13-3 New Circuit Description	13-7

Chapter 14 Reference Information

■ 14-1 Other issues related to other products	14-1
■ 14-2 Technical Terms	14-3

1. Precaution

To avoid possible damages or electric shocks or exposure to radiation, follow the instructions below with regard to safety, installation, service and ESD.

1-1 Safety Precautions

1. Make sure all protective devices are properly installed including non-metallic handles and compartment covers when installing or re-installing the chassis or chassis assemblies.
2. Make sure that no gaps exist between the cabinets for children to insert their fingers in to prevent children from receiving electric shocks.

Errors may occur when the resistance is below 1.0 M Ω or over 5.2 M Ω .

In these cases, make sure that the device is repaired before sending it back to the customer.

3. Check for Electricity Leakage (Figure 1-1)
Warning: Do not use an insulated transformer for checking the leakage. Use only those current leakage testers or mirroring systems that comply with ANSIC 101.1 and the Underwriter Laboratory's specifications (UL1410, 59.7).

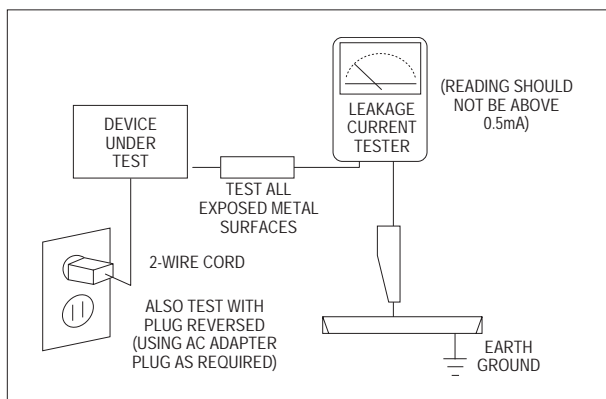

Fig. 1-1 AC Leakage Test



4. A high voltage is maintained within the specified limits using safety parts, calibration and tolerances. When voltage exceeds the specified limits, check each special part.
5. Warning for Engineering Changes:
Never make any changes or additions to the circuit design or the internal part for this product.
Ex: Do not add any audio or video accessory connectors. This might cause physical damage.
Furthermore, any changes or additions to the original design/engineering will invalidate the warranty.
6. Warning - Hot Chassis:
Some TV chassis are directly connected to one end of the AC power cord for electrical reasons.
Without insulated transformers, the product can only be repaired safely when the chassis is connected to the earthed end of the AC power source.

To make sure the AC power cord is properly connected, follow the instructions below. Use the voltmeter to measure the voltage between the chassis and the earthed ground. If the measurement is over 1.0V, unplug the AC power cord and change the polarity before re-inserting it. Measure the voltage between the chassis and the ground again.
7. Some TV chassis are shipped with an additional secondary grounding system. The secondary system is adjacent to the AC power line. These two grounding systems are separated in the circuit using an unbreakable/unchangeable insulation material.
8. When any parts, material or wiring appear overheated or damaged, replace them with new regular ones immediately. When any damage or overheating is detected, correct this immediately and make a regular check of possible errors.
9. Check for the original shape of the lead, especially that of the antenna wiring, any sharp edges, the AC power and the high voltage power. Carefully check if the wiring is too tight, incorrectly placed or loose. Never change the space between the part and the printed circuit board. Check the AC power cord for possible damages. Keep the part or the lead away from any heat-emitting materials.

Precaution

10. Safety Indication:

Some electrical circuits or device related materials require special attention to their safety features, which cannot be viewed by the naked eye. If an original part is replaced with another irregular one, the safety or protective features will be lost even if the new one has a higher voltage or more watts.

Critical safety parts should be bracketed with ( ). Use only regular parts for replacements (in particular, flame resistance and dielectric strength specifications). Irregular parts or materials may cause electric shock or fire.

11. Pay additional attention to the current leakage as the voltage between the power board and the ballast is 220 to 440v, i.e. very high.
And also beware of possible electric shock from the primary power source.

1-2 Servicing Precautions

Warning 1: First carefully read the "Safety Instruction" in this service manual.

When there is a conflict between the service and the safety instructions, follow the safety instruction at all times.

Warning 2: Any electrolytic capacitor with the wrong polarity will explode.

1. The service instructions are printed on the cabinet, and should be followed by any service personnel.
2. Make sure to unplug the AC power cord from the power source before starting any repairs.
 - (a) Remove or re-install parts or assemblies.
 - (b) Disconnect the electric plug or connector, if any.
 - (c) Connect the test part in parallel with the electrolytic capacitor.
3. Some parts are placed at a higher position than the printed board. Insulated tubes or tapes are used for this purpose. The internal wiring is clamped using buckles to avoid contact with heat emitting parts. These parts are installed back to their original position.
4. After the repair, make sure to check if the screws, parts or cables are properly installed. Make sure no damage is caused to the repaired part and its surroundings.
5. Check for insulation between the blade of the AC plug and that of any conductive materials (i.e. the metal panel, input terminal, earphone jack, etc).
6. Insulation Check Process: Unplug the power cord from the AC source and turn the switch on. Connect the insulating resistance meter (500v) to the AC plug blade.

The insulating resistance between the blade of the AC plug and that of the conductive material should be more than 1 M Ω .
7. Any B+ interlock should not be damaged. If the metal heat sink is not properly installed, no connection to the AC power should be made.
8. Make sure the grounding lead of the tester is connected to the chassis ground before connecting to the positive lead. The ground lead of the tester should be removed last.
9. Beware of risks of any current leakage coming into contact with the high-capacity capacitor.
10. The sharp edges of the metal material may cause physical damage, so ensure wearing protective gloves during the repair.

1-3 Static Electricity Precautions

1. Some semi-conductive ("solid state") devices are vulnerable to static electricity. These devices are known as ESD. ESD includes the integrated circuit and the field effect transistor. To avoid any materials damage from electrostatic shock, follow the instructions described below.
2. Remove any static electricity from your body by connecting the earth ground before handling any semi-conductive parts or ass'ys. Alternatively, wear a dischargeable wrist-belt.
(Make sure to remove any static electricity before connecting the power source - this is a safety instruction for avoiding electric shock)
3. Remove the ESD ass'y and place it on a conductive surface such as aluminum foil to prevent accumulating static electricity.
4. Do not use any Freon-based chemicals. Such chemicals will generate static electricity that causes damage to the ESD.
5. Use only grounded-tip irons for soldering purposes.
6. Use only anti-static solder removal devices. Most solder removal devices do not support an anti-static feature. A solder removal device without an anti-static feature can store enough static electricity to cause damage to the ESD.
7. Do not remove the ESD from the protective box until the replacement is ready. Most ESD replacements are covered with lead, which will cause a short to the entire unit due to the conductive foam, aluminum foil or other conductive materials.
8. Remove the protective material from the ESD replacement lead immediately after connecting it to the chassis or circuit ass'y.
9. Take extreme caution in handling any uncovered ESD replacements. Actions such as brushing clothes or lifting your leg from the carpet floor can generate enough static electricity to damage the ESD.

CAUTION

These servicing instructions are for use by qualified service personnel only. To reduce the risk of electric shock do not perform any servicing other than that contained in the operating instructions unless you are qualified to do so.

1-4 Installation Precautions

1. For safety reasons, more than two people are required for carrying the product.

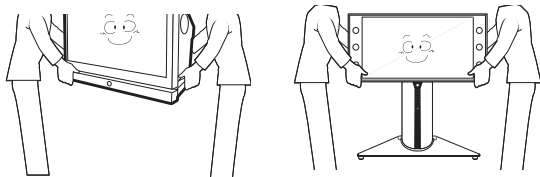

2. Keep the power cord away from any heat emitting devices, as a melted covering may cause fire or electric shock.
3. When installing the product, make sure to keep it away from the wall (more than 10cm/4 inches) for ventilation purposes. Poor ventilation may cause an increase in the internal temperature of the product, resulting in a shortened component life and degraded performance.
4. Bend the external antenna cable when connecting it to the product. This is a measure to protect it from being exposed to moisture. Otherwise, it may cause a fire or electric shock.
5. Make sure to turn the power off and unplug the power cord from the outlet before repositioning the product. Also check the antenna cable or the external connectors if they are fully unplugged. Damage to the cord may cause fire or electric shock.
6. Keep the antenna far away from any high-voltage cables and install it firmly. Contact with the high-voltage cable or the antenna falling over may cause fire or electric shock.
7. When connecting the RF antenna, check for a DTV receiving system and install a separate DTV reception antenna for areas with no DTV signal.
8. Check the basics of the screen test.
 - Image position/size, Tilt adjustment, Actuator activation

MEMO

2. Product Specification

2-1 Product Features

Block	Specification	Major IC	Remark
DMD	- Panel Resolution : 1280 x 720 (Diamond Pixel)	HD4 DMD Panel(L620 Engine)	
RF	- Integrated HDTV Tuner (NTSC/ATSC/QAM TUNER Embedded)	ATI T313	
Power	- Input Voltage : AC110V - Stand-By : under 30W	Stand-by (KA1M0565)	
Video	- DNIe3-NTSC, ATSC-HDMI, PC -3D Comb filter	ADV7401, ATI X226B, uPD64083	
Sound	- Speaker : 20W x 2 - Trusurround XT, Dolby Digital	MSP4440	
Cabinet	- L6 Design		

■ Chip Description

- ATI x226B : Xilleon 226 is the most advanced and highly integrated component for digital set-top boxes, information appliances, and televisions. Xilleon 226 provides dual-stream high-definition decode and display, an assortment of peripheral device controllers, and an embedded microprocessor.
- ADV7401 : The ADV7401 is an integrated video decoder that automatically indicates and converts High Definition or Standard Definition analog baseband television signal into a 4:2:2 component digital video data stream compatible with 20/16-bit or 10/8-Bit CCIR601/CCIR656 outputs for standard definition & SMPTE293M/296M/274M & ITU-R.BT1358 for High definition. All RGB graphics signals are output as 30-bit 4:4:4 RGB or 20-bit 4:2:2 YCrCb.
- MSP4440 : The MSP 44x0G family of single-chip Multistandard Sound Processors covers the sound processing of all analog TV-Standards worldwide, as well as the NICAM digital sound standards.
- ATI T313 : ATI T313 is an advanced QAM, NTSC, and VSB demodulator chip designed to operate in the Digital Cable Ready, analog NTSC, and ATSC terrestrial broadcast environments. ATI T313 also incorporates a QPSK forward data channel (FDC) receiver and a BTSC/Dual-FM demodulator and decoder enabling a complete digital and analog TV solution with a minimum number of components.
- uPD64083 : uPD64083 realizes a high precision Y/C separation and a noise reduction by the three-dimension signal processing for NTSC signal.

2-2 Key Features

Model	HL-R4667W	HL-R5067W	HL-R5667W	HL-R6167W
Voltage	AC 110~120V			
Frequency of Operation	60Hz			
Power Consumption	230 watts			
Dimensions (W x D x H)	42.83 x 13.44 x 32.05 inches 1088 x 341.5 x 814 mm	46.54 x 14.00 x 34.25 inches 1182 x 355.5 x 870 mm	52.36 x 15.26 x 37.87 inches 1330 x 387.5 x 962 mm	56.93 x 18.37 x 41.59 inches 1446 x 466.5 x 1056.5 mm
Weight	30.3 Kg / 66.80 lbs	33 Kg / 72.75 lbs	36.7 Kg / 80.91 lbs	42.9 Kg / 94.58 lbs

■ H/W Configuration

- DMD Panel : 0.55" (1280 x 720p, TI)
- 1 Optical Engine for the Panel : Slim and Cost-effective
- Color Wheel : R/G/B Color Implementation
- Lamp : 100W (10,000 hours) → Dynamic Mode 120W Drive (6,000 hours)
- 2 NTSC/ATSC/QAM Tuners : NTSC/DTV Reception
- Support HDMI Interface : Adopts DVI/HDMI systems for digital HDs including STB.
- DNle3 : High quality image implementation
- AnyNet Feature : An enhanced interface for various external devices
- USB Interface : Use the USB interface for service purposes (S/W Upgrade)

■ S/W Configuration

- MCU : Built-in 300 MHz MIPS X226B CPU
- 4-Layered Architecture : Device Driver/OS/Hardware Abstraction/Application
- OSD : 32Bit True Color Graphics OSD
- Enhanced system stability by separating the DTV control and the application control systems into multi-processes.

■ Picture

- DMD Panel
 - * Panel Size : 0.55"
 - * Panel Resolution : 1280 x 720 (Diamond Pixel)
- Tuner : Integrated HDTV Tuner (NTSC/ATSC/QAM TUNER Embedded)
- Display Format : 1280 x 720 (Diamond Pixel)

■ Sound

- Sound System : Dolby Digital
- Amp/Channel : 2 Channel Digital Amp
- Speaker System & Output(RMS)
 - * Main L/R : 15W + 15W
 - * Sound (RMS) : 15W + 15W

■ In/Out Terminals

- Side : 1 CVBS In, 1 S-VHS In
- Rear : 2 RF In, 2 CVBS In, 2 S-VHS In, 2 Component In,
1 HDMI In(DVI Comportable With Adaptive Jack Only), 1 Anynet port, 2 IEEE1394, 1 Gemstar IR out, 1 Optical audio,
1 POD Card slot

■ Feature

- Component Interface (480i/480p/720p/1080i, Y/Pb/Pr)
- Digital Interface : HDMI
- Graphic Interface : PC
- Language : English/French/Spanish
- PIP : HD/SD PiP
- Picture Size : 4:3/16:9/Zoom1/Zoom2/Panorama
- V-CHIP
- Closed Caption
- Sleep Timer : 180 Min.
- Anynet Interface
- IEEE1394
- Optical sound output
- Gemstar IR output
- POD

■ Remocon

- TM76







■ Power Supply

- 110V









■ PIP Settings (X : PIP doesn't operate, ▲ : PIP operate and swap doesn't operate, ○ : PIP and swap operate)

Main Sub	ATSC	QAM	NTSC	AV1	AV2	AV3	S-Video1	S-Video2	S-Video3	Component1	Component2	HDMI	PC	D-Net
ATSC	X	X	X	X	X	X	X	X	X	X	X	X	X	▲
QAM	X	X	X	X	X	X	X	X	X	X	X	X	X	▲
NTSC	▲	▲	○	○	○	○	○	○	○	○	○	▲	▲	▲
AV1	▲	▲	○	X	○	○	○	○	○	○	○	▲	▲	▲
AV2	▲	▲	○	○	X	○	○	○	○	○	○	▲	▲	▲
AV3	▲	▲	○	○	○	X	○	○	○	○	○	▲	▲	▲
S-Video1	▲	▲	○	○	○	○	X	○	○	○	○	▲	▲	▲
S-Video2	▲	▲	○	○	○	○	○	X	○	○	○	▲	▲	▲
S-Video3	▲	▲	○	○	○	○	○	○	X	○	○	▲	▲	▲
Component1	▲	▲	○	○	○	○	○	○	○	X	○	▲	▲	X
Component2	▲	▲	○	○	○	○	○	○	○	○	X	▲	▲	X

2-3 Specifications Analysis

Model		HL-R4667W	HL-R5067W	HL-R5667W	HL-R6167W	HL-R5087W	HL-R5687W
Design							
Picture	Display Device	DLP	DLP	DLP	DLP	DLP	DLP
	Built-in Tuner	ATSC, NTSC	ATSC, NTSC	ATSC, NTSC	ATSC, NTSC	ATSC, NTSC	ATSC, NTSC
	Display Format	1080i, 720p, 480p, 480i	1080i, 720p, 480p, 480i	1080i, 720p, 480p, 480i	1080i, 720p, 480p, 480i	1080i, 720p, 480p, 480i	1080i, 720p, 480p, 480i
	Screen Size	46 inch	50 inch	56 inch	61 inch	50 inch	56 inch
	Aspect ratio	16:9	16:9	16:9	16:9	16:9	16:9
	Progressive scan	Yes	Yes	Yes	Yes	Yes	Yes
	Digital Comb Filter	3D Comb	3D Comb	3D Comb	3D Comb	3D Comb	3D Comb
	First Surface Mirror	Yes	Yes	Yes	Yes	Yes	Yes
	Brightness	750cd/m ²	750cd/m ²	750cd/m ²	750cd/m ²	800cd/m ²	800cd/m ²
	Contrast	1500:1	1500:1	1500:1	1500:1	2500:1	2500:1
	Color Wheel Size/Bearing	7segment/65 φ , Air Bearing	7segment/65 φ , Air Bearing	7segment/65 φ , Air Bearing	7segment/65 φ , Air Bearing	7segment/65 φ , Air Bearing	7segment/65 φ , Air Bearing
	Anti-glare Sun Screen	Yes	Yes	Yes	Yes	Yes	Yes
	Screen Pitch	0.098mm	0.098mm	0.098mm	0.098mm	0.098mm	0.098mm
	Image enhancer	DNle3	DNle3	DNle3	DNle3	DNle3	DNle3
Audio	Base/Tremble/Balance	No	No	No	No	No	No
	Equalizer	5 Band	5 Band	5 Band	5 Band	5 Band	5 Band
	Auto Volume Leveler	Yes	Yes	Yes	Yes	Yes	Yes
	Surround Sound	TruSurround XT Dolby Digital	TruSurround XT Dolby Digital	TruSurround XT Dolby Digital	TruSurround XT Dolby Digital	TruSurround XT Dolby Digital	TruSurround XT Dolby Digital
	Speaker system	2 Way 4 Speaker	2 Way 4 Speaker	2 Way 4 Speaker	2 Way 4 Speaker	2 Way 4 Speaker	2 Way 4 Speaker
Output Power	15Wx2	15Wx2	15Wx2	15Wx2	15Wx2	15Wx2	
Features	2-Tuner Split-Screen PIP	Yes(HD/SD)	Yes(HD/SD)	Yes(HD/SD)	Yes(HD/SD)	Yes(HD/SD)	Yes(HD/SD)
	Split-screen Side-by-Side	Yes	Yes	Yes	Yes	Yes	Yes
	MTS with dbx Noise Reduction/SAP	Yes	Yes	Yes	Yes	Yes	Yes
	Still Picture	Yes	Yes	Yes	Yes	Yes	Yes
Connections	Plug & Play	Yes	Yes	Yes	Yes	Yes	Yes
	EPG	Gemstar EPG	Gemstar EPG	Gemstar EPG	Gemstar EPG	Gemstar EPG	Gemstar EPG
	Anynet	Yes	Yes	Yes	Yes	Yes	Yes
	S-Video In	Rear 2/Side 1	Rear 2/Side 1	Rear 2/Side 1	Rear 2/Side 1	Rear 2	Rear 2
	HDTV Component Video Input (Y, Pb, Pr) 1080i/480P/480i	Rear 2	Rear 2	Rear 2	Rear 2	Rear 2	Rear 2
	PC	Yes	Yes	Yes	Yes	No	No
	Digital Sound	Optical 1	Optical 1	Optical 1	Optical 1	Optical 1	Optical 1

2-4 Accessories

Accessories	Item	Item code	Remark	
Supplied Accessories		Remocon Alkaline Battery	BP59-00071B 4301-000103	Samsung Service center
		Manual	BP68-00469A	
		ANYNET cable	BN39-00518B	
		G-Link Cable	MD96-00036A	
Accessories that can be purchased additionally		Video Cable / Audio Cable	-	Internal shopping mall
		Antenna Cable	-	
		Component Cable	-	
		Optical Cable	-	

MEMO

3. Alignment & Adjustment

3-1 Service Instruction

■ Check items listed after changing each

Replaced Items \ Check Items	S/W Version	Front LED	Index Delay	Actuator Gain	V-Position H-Position	CCA	Board LED	Tilt Focus
Digital Board	●(1st)		●(3rd)	●(5th)	●(2nd)	●(4th)		
Analog Board		●					●	
Power Board		●					●	
Optical Engine		●	●(3rd)	●(5th)	●(2nd)	●(4th)		●(1st)
DMD Board				●				●
Lamp		●				●		
Color Wheel						●		
Front LED Assy		●						
Actuator Subdetector Board		●						

※ If you change digital board and optical engine, check in order.
(For example, in case of "D/B", first 'S/W', second 'V/H position' and third 'Index'...)

1. Software version check :

After Entering the Service mode, Check the list below

* S/W Notation

"T_HURRAUS0_0004" indicates "HURRICANE BASIC MODEL USA, ver. 0004".

T_HURRAUS0_0004
2005_XX_XX
T-DTVUCOM5-00XX
T-HURRAUS0_00XX

2. Front LED check : See page 6-11.

3. Index Delay adjustment : See page 3-13.

4. Actuator Gain adjustment : See page 3-15.

5. Vertical / Horizontal Position adjustment : See page 3-13.

6. CCA : See page 3-14.

7. Board LED check : Check all the LED are turned on.

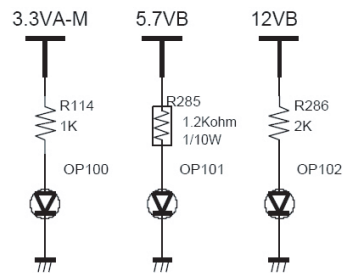

Power Check Indicator LED

8. Tilt/Focus adjustment : See page 3-17.

3-2 How to Access Service Mode

1. Turn off the power to put the unit into the STAND-BY mode.
2. In order to enter the Service Mode, Press "Mute" → "1" → "8" → "2" → "POWER" button on the Remote Control.
In case entry into SERVICE MODE is unsuccessful, repeat the procedures above.
3. Initial DISPLAY State in times of Service Mode Switch overs

```

DDP1011(L6)
DNle
ADV7401(M)
ADV7401(S)
Xilleon226
uPD64083
MSP4440
CCA(ON)
Cinema CCA
SP Actuator
ESP
CHECKSUM      0000
OPTION
SERVICE

T_HUR2AUS0_XXXX
200X_XX_XX
T-HURUCOM5-XXXX
T-HUR2AUS1_XXXX
    
```

4. Buttons operations within Service Mode

MENU	Full Menu Display / Move to Parent Menu
Direction keys ▲ / ▼	Item Selection by Moving the Cursor
Direction keys ◀ / ▶	Data Increase/Decrease for the Selected Item
Source	Cycles through the active input source that are connected to the unit

3-3 Factory Data

★ The underlined are items applied during the service adjustment. None of the others should be adjusted.

1. DDP1011

No	Item	Range	Default	Remark
1	<u>V-Position</u>	0-60	36	Screen upper and lower adjustment
2	<u>H-Position</u>	0-120	60	Screen left and right adjustments
3	LAMP SYNC		Pulse(P)	Pulse(P), Pass(T)
4	<u>INDEX DELAY</u>	0-359	40	Synchronizes the base position of the color wheel with the corresponding color signal. This is critical to the natural color display. If the index delay is not properly set, even the correct CCA coordinates will not help when displaying natural colors.
5	SEQ SELECT	0-15	5	Sequence Selection
6	<u>V-FLIP</u>	Normal/Flip	Normal	Vertical Flip Operation
7	<u>H-FLIP</u>	Normal/Flip	Normal	Horizontal Flip Operation
8	GAMMA	0 ~ 15	2	Gamma Table Selection
9	SLR	OFF/ON	OFF	SLR Function On/Off
10	DMD_BIAS	B,C,D,E	E	DMD Bias pin voltage selection
11	Lamp Boost	0-63	20	Lamp Boost value selection
12	Lamp Sync Delay	0-4095	0	Lamp Sync delay value selection
13	Engine Select		SAMSUNG	SAMSUNG and ZEISS Selection
14	Lamp Watt		120W	120W/132W Selection
15	Lamp Select		Philips	Philips/Osram/Ushio
16	<u>Test Pattern</u>		0	This displays the built-in pattern of the DDP1011 chip. DDP1011 drives the DMD panel, so displaying this pattern means there is no error in the DDP1011 projection function and the panel itself.

2. DNle

No	Item	Range	Default	Remark
1	Test Pattern		0	Test Pattern Selection
2	NR_MAX Y/C	0~255	48	Temporal NR Gain
3	NR_MIN Y/C	0~255	16	Temporal NR Gain
4	Core	0~15	4	NEOnDCE User Set Up
5	B_RATIO		12000	Low level information for the minimum value
6	BLACK_TILT	0~255	120	Black Stretch Area
7	W_RATIO		12000	High level information for the minimum value
8	WHITE_TILT	0~255	200	White Stretch Area
9	GAIN1X	0~63	30	Gain of horizontal high frequency region
10	GAIN1Y	0~63	20	Gain of vertical high frequency region
11	GAIN2X	0~63	17	Gain of horizontal middle frequency region
12	GAIN2Y	0~63	13	Gain of vertical middle frequency region
13	GAIN3X	0~63	11	Gain of horizontal low frequency region
14	NDON		ON	ON,OFF Background Noise Detection ON/OFF Switch
15	CORING_ON		ON	ON,OFFCoring On/Off
16	SCALE_R	0~255	160	Log Mapping Gain
17	WTE_CSC		YCCRGB	YCCRGB, YPPRGB
18	DITHER_MOD		0	1,2,3
19	RED_C_COEFF		128	Gain adjustment of the contrast for the Red signal
20	GRN_C_COEFF		128	Gain adjustment of the contrast for the Green signal
21	BLU_C_COEFF		128	Gain adjustment of the contrast for the Blue signal
22	RED_B_COEFF		128	Gain adjustment of the brightness for the Red signal
23	GRN_B_COEFF		128	Gain adjustment of the brightness for the Green signal
24	BLU_B_COEFF		128	Gain adjustment of the brightness for the Blue signal
25	Sub Contrast	0~150	120	Brightness adjustment for the high-light parts of the screen
26	Sub Brightness		230	Brightness adjustment for the low-light parts of the screen
27	ALPMAU/L	0~255	50	

3. ADV7401(M)

No	Item	Range	Default	Remark
1	AUTO COLOR			Auto Color function execution
2	SOG_SYNC_LEV			Embedded Sync Trigger Level
3	AGC_TIM			AGC Time Constant Selection
4	GAIN_MAN			ON,OFF Manual Gain Control Enable
5	A_GAIN			Manual Gain Value for Channel A
6	B_GAIN			Manual Gain Value for Channel B
7	C_GAIN			Manual Gain Value for Channel C
8	A_OFFSET			Channel A Offset
9	B_OFFSET			Channel B Offset
10	C_OFFSET			Channel C Offset
11	YPM	0~7	4	Y Peaking Filter Mode
12	YSFM	0~32	1	Y Shaping Filter Mode
13	WYSFM	0~32	19	Wide Band TY Shaping Filter Mode
14	CSFM		0	C Shaping Filter Mode
15	Contrast	0~255	128	Contrast Adjust
16	Brightness	0~255	128	Brightness Adjust
17	Hue	0~255	128	Hue Adjust
18	CKILLTHR	0~7	3	Colour Kill Threshold
19	SD_OFF_Cb	0~255	128	SD Offset Cb Channel
20	SD_OFF_Cr	0~255	128	SD Offset Cr Channel
21	SD_SAT_Cb	0~255	128	Saturation Cb Channel
22	SD_SAT_Cr	0~255	128	Saturation Cr Channel
23	IFFILTSEL	0~7	3	IF Filter Select
24	LTA	0~3	0	Luma Timing Adjust
25	CTA	0~7	2	Chroma Timing Adjust
26	DNR_TH1	0~255	0	DNR Noise Threshold
27	DCT	0~3	0	Digital Clamp Timing
28	LAGC	0~7	0	Luma Automatic Gain Control
29	LAGT	0~3	3	Luma Automatic Gain Timing
30	LMG		1144	Luma Manual Gain
31	CAGC	0~7	5	Chroma Automatic Gain Control
32	CAGT	0~3	3	Chroma Automatic Gain Timing
33	CMG		2458	Chroma Manual Gain
34	CTI_AB_EN		ON	ON,OFF Chroma Transient Improvement Alpha Blend Enable
35	CTI_AB	0~3	3	Chroma Transient Improvement Alpha Blend

No	Item	Range	Default	Remark
36	CTI_C_TH	0-255	8	CTI Chroma Threshold
37	NSFSEL	0-3	0	Split Filter Selection NTSC
38	CTAPSN	0-3	2	Chroma Comb Taps NTSC
39	CCMN	0-7	0	Chroma Comb mode NTSC
40	YCMN	0-7	0	
41	HSSLICE			
42	VSSLICE			
43	DLL_PH			
44	ST_NOISE		0xFFFF	
45	ALIAS_FILTER_EN			
46	DNR_TH2		4	

4. ADV7401(S)

No	Item	Range	Default	Remark
1	AUTO COLOR			Auto Color function execution
2	SOG_SYNC_LEV	0~31	11	Embedded Sync Trigger Level
3	AGC_TIM	0~7	0	AGC Time Constant Selection
4	GAIN_MAN		ON	ON,OFF Manual Gain Control Enable
5	A_GAIN	0~1024	275	Manual Gain Value for Channel A
6	B_GAIN	0~1024	287	Manual Gain Value for Channel B
7	C_GAIN	0~1024	287	Manual Gain Value for Channel C
8	A_OFFSET	0~1024	0	Channel A Offset
9	B_OFFSET	0~1024	512	Channel B Offset
10	C_OFFSET	0~1024	512	Channel C Offset
11	YPM	0~7	4	Y Peaking Filter Mode
12	YSFM	0~32	1	Y Shaping Filter Mode
13	WYSFM	0~32	19	Wide Band TY Shaping Filter Mode
14	CSFM	(0~7)	0	C Shaping Filter Mode
15	Contrast	0~255	128	Contrast Adjust
16	Brightness	0~255	126	Brightness Adjust
17	Hue	0~255	128	Hue Adjust
18	CKILLTHR	0~7	3	Colour Kill Threshold
19	SD_OFF_Cb	0~255	128	SD Offset Cb Channel
20	SD_OFF_Cr	0~255	128	SD Offset Cr Channel
21	SD_SAT_Cb	0~255	128	Saturation Cb Channel
22	SD_SAT_Cr	0~255	128	Saturation Cr Channel
23	IFFILTSEL	0~7	3	IF Filter Select
24	LTA	0~3	0	Luma Timing Adjust
25	CTA	0~7	3	Chroma Timing Adjust
26	DNR_TH	0~255	0	DNR Noise Threshold
27	DCT	0~3	0	Digital Clamp Timing
28	LAGC	0~7	0	Luma Automatic Gain Control
29	LAGT	0~3	3	Luma Automatic Gain Timing
30	LMG	0~4096	1064	Luma Manual Gain
31	CAGC	0~7(0~3)	2	Chroma Automatic Gain Control
32	CAGT	0~3	3	Chroma Automatic Gain Timing
33	CMG	0~4096	2458	Chroma Manual Gain
34	CTI_AB_EN		ON	ON,OFF Chroma Transient Improvement Alpha Blend Enable
35	CTI_AB	0~3	3	Chroma Transient Improvement Alpha Blend

No	Item	Range	Default	Remark
36	CTI_C_TH	0~255	8	CTI Chroma Threshold
37	NSFSEL	0~3	0	Split Filter Selection NTSC
38	CTAPSN	0~3	2	Chroma Comb Taps NTSC
39	CCMN	0~7	0	Chroma Comb mode NTSC
40	YCMIN	0~7	0	
41	HSSLICE	0~3	1	
42	VSSLICE	0~3	3	
43	DLL_PH			
44	ST_NOISE		0xFFFF	

5. Xilleon226

No	Item	Range	Default	Remark
1	Main/Sub		Main	
2	Y/UV		Y	
3	Filter		gh121a	

6. Upd64083

No	Item	Range	Default	Remark
1	DYCOR	0 ~ 15	2	DY detection coring level
2	DYGAIN	0 ~ 15	9	DY detection gain
3	DCCOR	0 ~ 15	3	DC detection coring level
4	DCGAIN	0 ~ 15	6	DC detection gain
5	YHCOR	0 ~ 3	1	Y output high frequency component coring
6	CDELAY	0 ~ 3	4	C signal output delay
7	YPFT		3	YPFT adjustment
8	YCFG		8	YCFG adjustment

7. MSP4440

No	Item	Range	Default	Remark
1	MDB Effect	0~127	56	Micronas Dynamic Bass
2	SRS Dialog	0~127	64	SRS Dialog clarity adjustment
3	PLL			Pilot low adjustment
4	PLH			Pilot high adjustment

8. CCA(ON)

No	Item	Range	Default	Remark
1	CCA	On/Off	On	CCA On/Off Selection
2	Red-x	0~32768	640	Red-x adjustment
3	Red-y	0~32768	340	Red-y adjustment
4	Red-Y	0~32768	86	Red-Y adjustment
5	Green-x	0~32768	300	Green-x adjustment
6	Green-y	0~32768	620	Green-y adjustment
7	Green-Y	0~32768	300	Green-Y adjustment
8	Blue-x	0~32768	150	Blue-x adjustment
9	Blue-y	0~32768	60	Blue-y adjustment
10	Blue-Y	0~32768	53	Blue-Y adjustment
11	White-x	0~32768	291	White-x adjustment
12	White-y	0~32768	300	White-y adjustment
13	White-Y	0~32768	439	White-Y adjustment
14	WB Spread			Spread CCA value to all mode
15	Move HDMI			Move to the HDMI Mode
16	DRedX			Target Red X value for CCA
17	DRedY			Target Red Y value for CCA
18	DGreenX			Target Green X value for CCA
19	DGreenY			Target Green Y value for CCA
20	DBlueX			Target Blue X value for CCA
21	DBlueY			Target Blue Y value for CCA
22	DCyanX			Target Cyan X value for CCA
23	DCyanY			Target Cyan Y value for CCA
24	DMagentaX			Target Magenta X value for CCA
25	DMagentaY			Target Magenta Y value for CCA
26	DYellowX			Target Yellow X value for CCA
27	DYellowY			Target Yellow Y value for CCA
28	D_White_X			Target White X value for CCA
29	D_White_Y			Target White Y value for CCA
30	ATV/AV/SV			

9. Cinema CCA

No	Item	Range	Default	Remark
1	DRedX		640	Target Red X value for CCA
2	DRedY		340	Target Red Y value for CCA
3	DGreenX		300	Target Green X value for CCA
4	DGreenY		620	Target Green Y value for CCA
5	DBlueX		150	Target Blue X value for CCA
6	DBlueY		60	Target Blue Y value for CCA
7	DCyanX		205	Target Cyan X value for CCA
8	DCyanY		270	Target Cyan Y value for CCA
9	DMagentaX		290	Target Magenta X value for CCA
10	DMagentaY		140	Target Magenta Y value for CCA
11	DYellowX		425	Target Yellow X value for CCA
12	DYellowY		515	Target Yellow Y value for CCA
13	D-White-X		313	Target White X value for CCA
14	D-White-Y		329	Target White Y value for CCA

10. SP Actuator

No	Item	Range	Default	Remark
1	Actuator Gain	0~175	115	Actuator Gain adjustment
2	Actuator On/Off		On	Actuator On/Off selection

11. ESP

No	Item	Range	Default	Remark
1	Dynamic Con		Off	Dynamic Contrast On/Off
2	Dynamic Strength		Medium	Low/Mid/Mas
3	Dynamic Con Gain	0~100	0	Dynamic Contrast Gain Adjustment
4	Dynamic Sat		Off	Dynamic Saturation On/Off
5	Dynamic Sat Gain	0~255	176	Dynamic Saturation Gain Adjustment
6	Sharp Picture		Off	Sharp Picture On/Off
7	Sharp Filter		HD Low	HD High/HD Low/SD Image
8	Sharp Picture Gain	0~255	176	Sharp Picture Gain Adjustment

12. CHECKSUM 0000

Excute Checksum calcaution

13. OPTION

No	Item	Range	Default	Remark
1	Lamp Clear			Initialize lamp usage time. Lamp Life is set to zero
2	-			All setting is back to the default
3	WB Reset		OFF	Initialize the White Balance value
4	EER Reset			Clear the EEPROM
5	Lamp Life		0h	Lamp on time counter
6	AUTO POWER	ON/OFF	ON	The sets turns on automatically when the power cord is plugged in
7	DNle DEMO	ON/OFF	ON	DNle Demo function selection
8	Lamp Control		Dynamic	Dynamic, Always
9	MUTE TIME		600ms	Time which the screen will be black while switching channels
10	EDID WRITE			
11	DELAY MOD	ON/OFF	OFF	Sound Delay Module ON/OFF selection
12	DBG/ANY SEL	Debug/AnyNet		Select the use of the Anynet jack
13	GEM/GEMIR SEL	GemIR/Gemstar		Not used
14	226 TEST PATT			Xilleon 226 test pattern
15	Set Default Data			Initialize Service Data
16	DDC protection		OFF	DDC write ON/OFF selection
17	LNA Default		AUTO	LNA setting OFF/Auto selection
18	PROTECT		ON	Protection ON/OFF selection
19	WATCH DOG			Watch Dog ON/OFF selection
20	WD COUNT		0	Count for Watch Dog event
21	Auto Pgm Range		8	Not used
22	DIGITAL→DMD			Transfer engine adjustment data from digital to DMD
23	DMD→DIGITAL			Transfer engine adjustment data from DMD to digital

14. SERVICE

No	Item	Range	Default	Remark
1	V-Position	0 ~ 60	30	Screen upper and lower adjustment
2	H-Position	0 ~ 120	60	Screen left right adjustment
3	LAMP SYNC	Pulse/Pass	Pulse	
4	Actuator Gain		105	Actuator Gain adjustment
5	INDEX DELAY	0 ~ 1023	166	Index delay adjustment
6	AUTO COLOR		OFF	Auto Color function execution
7	CCA			CCA menu
8	Lamp Clear			Initialize Lamp usage time
9	User Reset			All setting is back to the default
10	Engine Select		SAMSUNG	SAMSUNG and ZEISS Selection
11	Lamp Watt		120W	120W/132W Selection
12	Lamp Select		Philips	Philips/Osram/Ushio

3-4 Service Adjustment

3-4-1 Vertical / Horizontal Position Adjustment

1. Turn off the power to put the unit into the STAND-BY mode.
 2. In order to enter the Service Mode, Press "Mute" → "1" → "8" → "2" → "POWER" button on the Remote Control.
 3. Select "Service" on the first display of the Service mode menu.
 4. Select the V-position for vertical positioning and H-position for horizontal positioning by using the ▲ ▼ (up, down) buttons.
- ※ Do not set the V-position value to 34 or 35. (Setting to these values will cause horizontal lines on the right side of the screen.)

3-4-2 INDEX DELAY Adjustment

1. Turn off the power to put the unit into the STAND-BY mode.
2. In order to enter the Service Mode, Press "Mute" → "1" → "8" → "2" → "POWER" button on the Remote Control.
3. Select "Service" on the first display of the Service mode menu.
4. Press the ▲ ▼ (Up or Down) button to move to INDEX DELAY, then press ENTER to select.
5. The INDEX DELAY setup screen (with a red bar at the bottom of the screen) will be displayed.
6. Press the ◀▶ (Left of Right) button to check the red color at the bottom of the screen at its minimum and maximum values of changing from red to magenta, then adjust to the mean value.

3-4-3 CCA Adjustment Service Methods : CCA Adjustment is needed after changing a light engine or digital board

■ CCA : In DLP TV, even the same RGB color may differ depending on the light engine. CCA (Color Coordinate Adjustment) corrects the color to achieve the color accuracy. CCA performs color correction after measuring and inputting the current light engine's data on actual color coordinates for displayed Red, Green, Blue, and White color patterns, using a color coordinate measuring equipment.

At this moment, color correction is performed on the basis of previously inputted Desired Color Coordinates and Measured Color Coordinates. Measured Data on Service Engine's color coordinates is presented on the CCA label. Input the label values to perform CCA color correction.

1. Condition of the CCA Label upon Receipt of the Service Engine

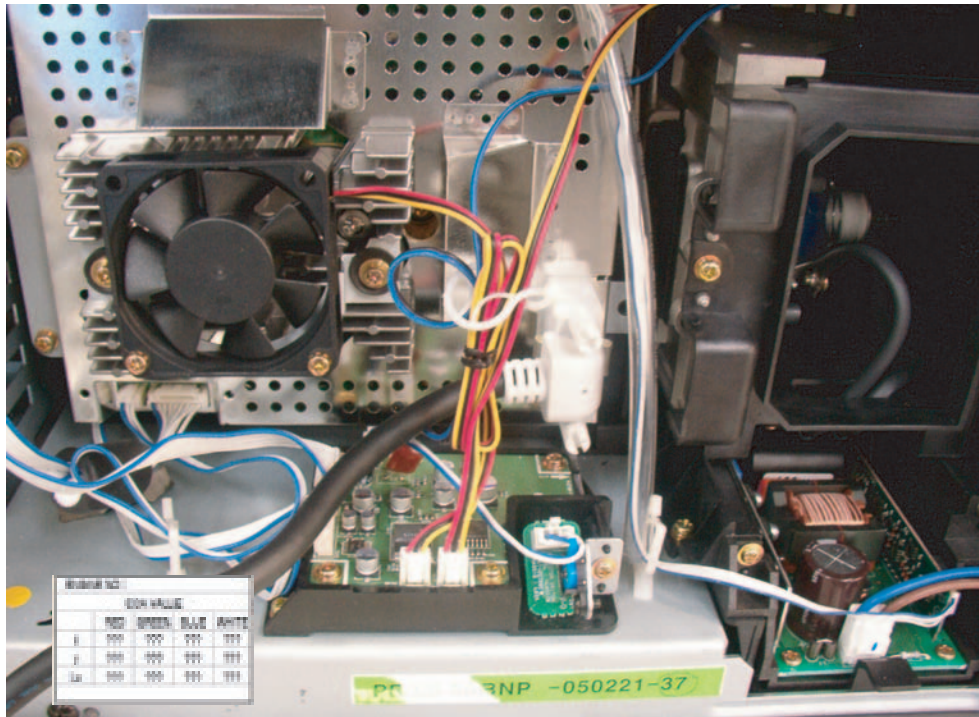

* "CCA LABEL" describes the measured color coordinates on the light engine.

2. CCA Service Procedures

To execute CCA adjustment , perform the following steps :

- 1) Turn off the power to put the unit into the STAND-BY mode.
- 2) In order to enter the Service Mode, Press "Mute" → "1" → "8" → "2" → "POWER" button on the Remote Control.
- 3) From the Factory Service Mode Menu; select SERVICE > CCA.
- 4) Switch the CCA OFF.
- 5) Enter the CCA Red, Green, Blue and White basic engine data to the DLP.
- 6) Input the D-White-x, y values in the coordinates per destination. (if necessary)
- 7) Select WB SPREAD, then press Enter to activate the WB Spread SET ensuring that you adjust until you get the OK sign. After adjusting, exit Factory Mode.
- 8) When the adjustment is complete, check the picture quality.

*** Attention**

Performing CCA is independent on current display's resolution and input signal type if you don't measure color coordinates data.

Measuring color coordinates data requires specific equipment not possessed by service personnel, that makes performing manual adjustment impossible. Adjusting CCA is applied to all the signal mode. Don't change Desired value because it will be harmful to the color of the SET.

CCA Menu in FACTORY Mode

```

CCA ON/OFF
Red - x : ???
Red - y : ???
Red - Y : ???
Green - x : ???
Green - y : ???
Green - Y : ???
Blue - x : ???
Blue - y : ???
Blue - Y : ???
White - x : ???
White - y : ???
White - Y : ???
WB SPREAD
Move HDMI
    
```

3-4-4 ACTUATOR GAIN Adjustment

1. Before Adjustment

- 1) Turn off the power to put the unit into the STAND-BY mode.
- 2) In order to enter the Service Mode, Press "Mute" → "1" → "8" → "2" → "POWER" button on the Remote Control.
- 3) Select "Service" on the first display of the Service mode menu.
- 4) Press the ▲ ▼ (Up or Down) button to move to ACTUATOR GAIN, then press ENTER to select.

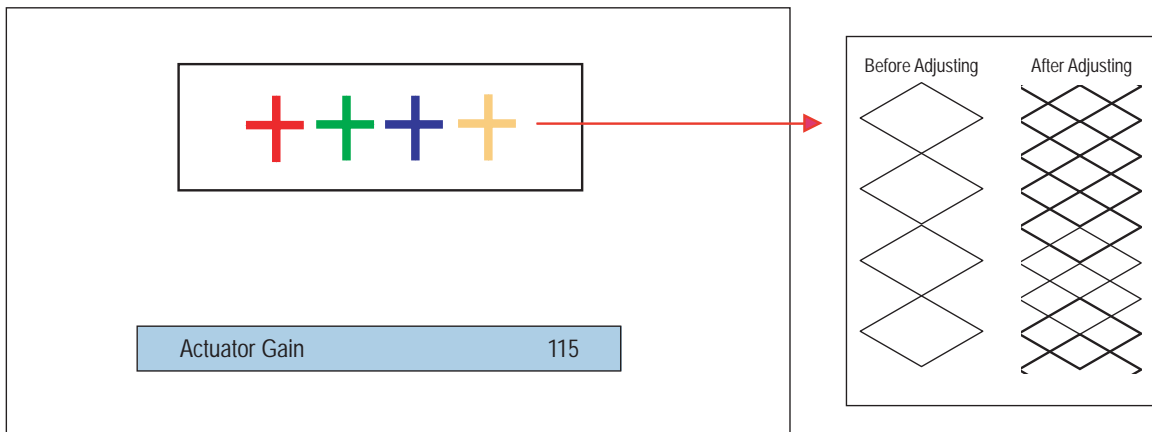

2. Making Adjustments

- 1) As shown in the picture above, change the actuator values to eliminate saw tooth shapes.
 - To fine tune, increase the data value ensuring that you get the center between the starting and ending points of the disappearing saw tooth shape.

3-5 Software Upgrade

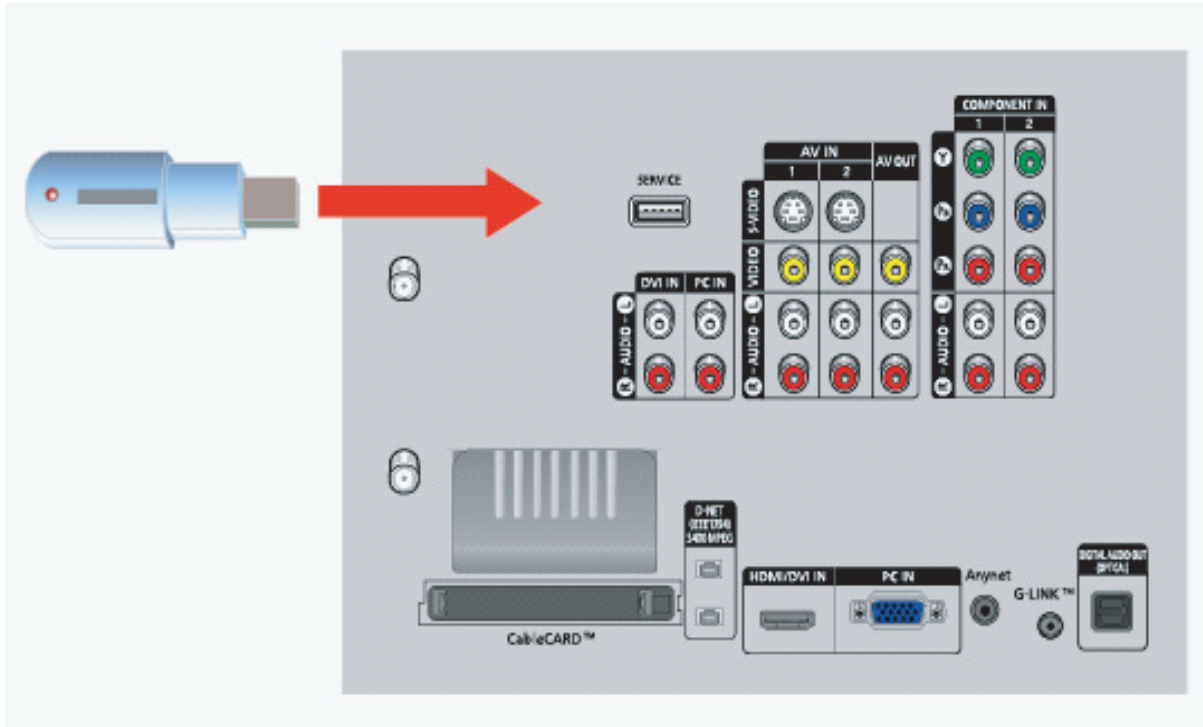

1. Prepare the USB memory stick with the built-in firmware.
2. While the TV is off, insert the USB stick into the SERVICE terminal.
3. When turning on the TV, there should be a long beeping tone and the firmware download process should start. If there is no sound from the TV, turn it off and then on again.
4. When the download is complete, there will be another long beeping tone and the TV will go into standby mode.

※ Check for the Firmware Version

- 1) Turn off the power to put the unit into the STAND-BY mode.
- 2) In order to enter the Service Mode, Press "Mute" → "1" → "8" → "2" → "POWER" buttons on the Remote Control.
- 3) In case entry into SERVICE MODE is unsuccessful, repeat steps 1 and 2 directly above.
- 4) You can check the firmware version at the bottom of the Factory menu.

```

T_HURRAUS0_0004
2005_XX_XX
T-DTVUCOM5-00XX
T-HURRAUS0_00XX
    
```



3-6 Replacements & Calibration

3-6-1 Tilt the Screen

1. Remove the 12 point screws. Remove the Bottom cover.
Fix the safety switch on the right with tape so that the set can be turned on after removing the bottom cover.
: TH,B,M4.L15,BLK,SWRCH18A

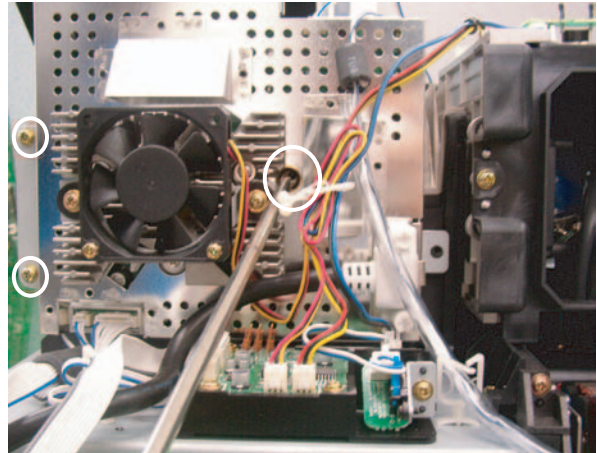

2. Remove the 3 points screws.
* Left 2 points screws
: PWH,S,M3,L8,ZPC(YEL),SWRCH18A
* Right 1 points screw
: PWH,S,M3,L7,ZPC(YEL),SWRCH18A



3. Turn off the power to put the unit into the STAND-BY mode.
In order to enter the Service Mode, Press "Mute" → "1" → "8" → "2" → "POWER" button on the Remote Control.
Select "DDP1011(L6)" on the first display of the Service Mode menu. Press the ▲ ▼ (Up or Down) button to move to TEST PATTERN, then press ENTER to select. Press the ► (Right) button until you see CROSSHATCH PATTERN.
Then, adjust the screen position, by holding both of the upper corners of the DMD board.

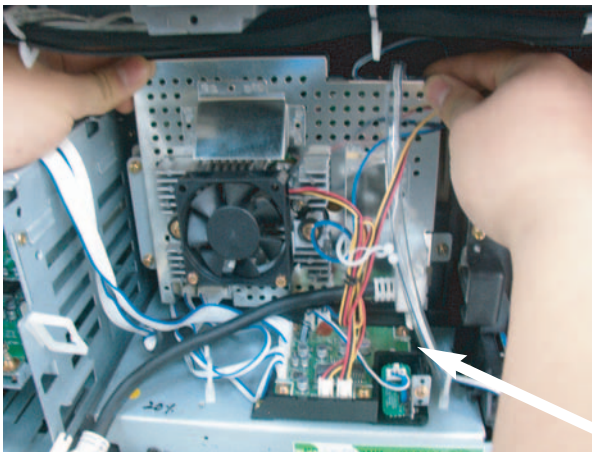

CROSSHATCH PATTERN

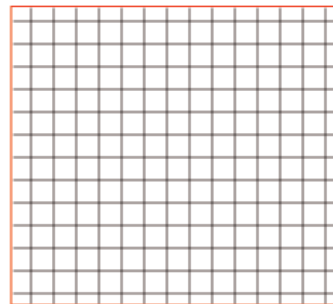

Fix the safety switch on the right with tape so that the set can be turned on after removing the bottom cover.

- ※ Even when those screws are removed, the board does not separate it can be moved within the adjustable range because there is a spring screw at the center that holds it.
- ※ When adjusting the screen, it is better for two people to work together.
One person should adjust the picture position while the other person looks at the screen.
- ※ The movement direction of the board and the picture are opposite.
 - When the board is lifted upward, the screen descends down.
 - When it is tilted to the left, the screen tilts to the right.
- ※ When the picture adjustment is completed:
First, tighten the two screws on the left of the DMD board and then slowly tighten the one screw on the bottom right.
Be careful not to touch the board while tightening the screws.
(When using an electric-powered screwdriver, be careful that the torque is not too high.)

3-6-2 Align the Focus

1. Loosen and remove the 5 screws on the terminal board and jack.
: TH,B,M4.L15,BLK,SWRCH18A

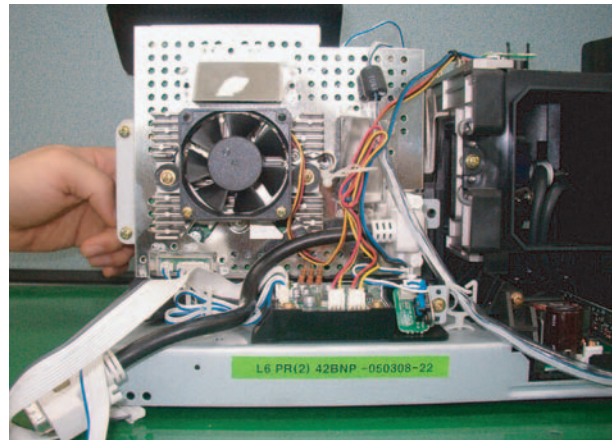

2. It is not necessary that engine assembly separate to adjust focus.
You put your hand in set below diagram. Move the focus alignment dial of Projection lens to the clockwise or counter clockwise until the picture is clear displayed. You are easy to work together another service man.

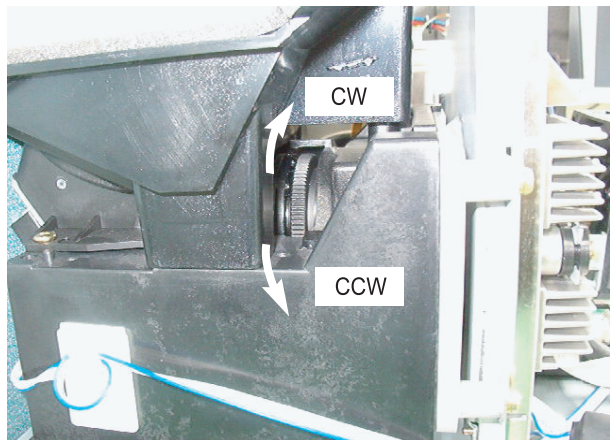
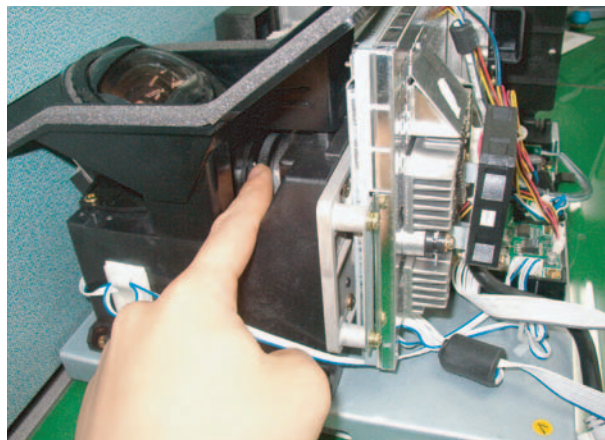

4. Exploded View & Part List

4-1 HLR4667W1X/XAA

You can search for the updated part code through ITSELF web site.

URL: <http://itself.sec.samsung.co.kr>

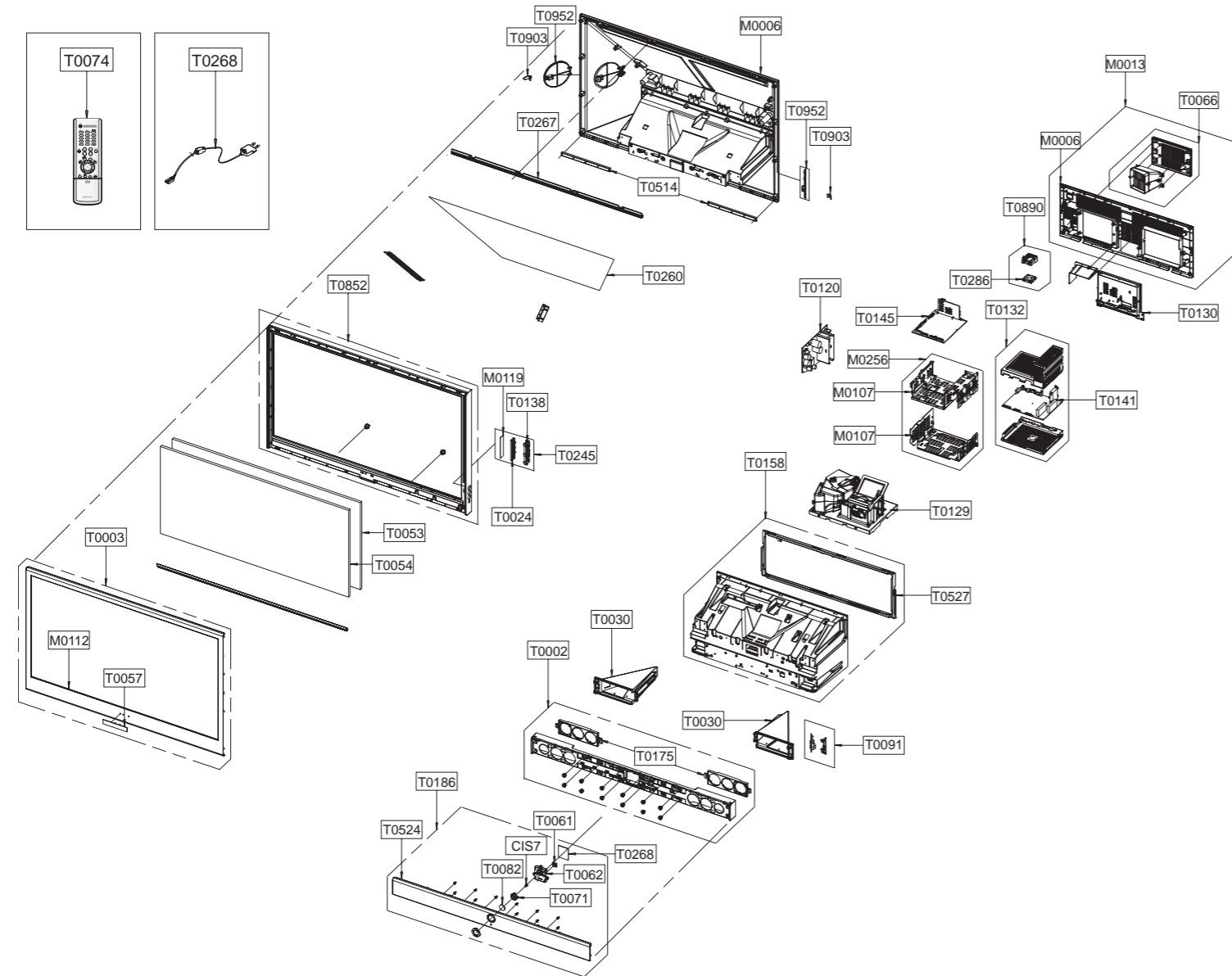

Loc. No.	Code No.	Description	Specification	Q'ty	SA/SNA	Remark
CIS7	AA61-60003J	SPRING ETC-CS	-,SUS304,-,-,OD6,N7,OD6,-,	1	S.N.A	
M0006	BP63-00400A	COVER-REAR	46L6,HIPS,HB,GRAY,TOP	1	S.A	
M0006	BP63-00401A	COVER-REAR BOTTOM	50L6,HIPS,V0,GRAY	1	S.N.A	
M0013	BP96-00938B	ASSY COVER P-REAR BOTTOM	L6,HIPS V0,GR50	1	S.A	
M0107	BP61-00892A	BRACKET-PCB	50L3,SECC,T1.0,NTR,TOP(BUILT	1	S.N.A	
M0107	BP61-00893A	BRACKET-PCB	50L3,SECC,T1.0,NTR,BOT(BUILT	1	S.N.A	
M0112	BP63-00398B	COVER-FRONT	46L6,HIPS,HB,BLK,BKM1326R1,S	1	S.N.A	
M0119	BP41-00124B	PCB CONTROL	HLP5063W,FR-4,2L,A,1.6T,245	1	S.N.A	
M0256	BP96-00849F	ASSY BRACKET P-MAIN PCB	L3,L6,L7,SECC,T1	1	S.A	
T0002	BP96-00961B	ASSY COVER P-FRONT BOTTOM	46L6,HIPS,HB,G	1	S.A	
T0003	BP96-00993B	ASSY COVER P-FRONT	46L6,SEA(L64B),HIPS H	1	S.A	
T0024	BP64-00384B	KNOB-FAMILY	L6,ABS,HB,GRAY,SVM-3012	1	S.N.A	
T0030	BP96-00970B	ASSY COVER P-SIDE	46L6,HIPS,HB,GR503,LEF	1	S.A	
T0030	BP96-00971B	ASSY COVER P-SIDE	46L6,HIPS,HB,GR503,RIG	1	S.A	
T0053	BP67-00182A	SCREEN FRESNEL	46W,1038*596,T1.5	1	S.A	
T0054	BP67-00181A	SCREEN LENTI	46W,1038*596,2.4T	1	S.A	
T0057	BP64-00177A	BADGE-BRAND	ALL,AL,T1.5,70,11.3,BLK,SILI	1	S.N.A	
T0061	BP64-00385A	WINDOW-REMOCON	50L3,PC,VIOLET	1	S.N.A	
T0062	BP61-00530A	HOLDER-POWER	50L3,HIPS HB,GRAY	1	S.N.A	
T0066	BP96-00535D	ASSY COVER P-DUCT	50L3,HIPS HB,GRY	1	S.N.A	
T0071	BP64-00382A	INDICATOR-LED	50L3,ABS CLEAR (LG)	1	S.N.A	
T0074	BP59-00071B	REMOCON	HURRICANE,TM76A,200*54*30,ZILOG	1	S.A	
T0082	BP64-00309B	WINDOW LED	50L3,ACRYL,2.0,half-mirror,SE	1	S.N.A	
T0091	BP94-02059C	ASSY PCB MISC-AV SIDE	HLR5067,L64B,L6	1	S.A	
T0120	BP94-02222H	ASSY PCB POWER	HLR5067(L6),L64C,120V(POD	1	S.N.A	
T0129	BP96-00824C	ASSY ENGINE P-DLP	46L6,OSRAM 120W,E23,OM	1	S.A	
T0130	BP96-00848E	ASSY COVER P-TERMINAL BOARD	L6,L64A,HIPS	1	S.A	
T0132	BP94-02084A	ASSY PCB MISC-DIGITAL	HLR4667W1X,L64C,L6	1	S.A	
T0138	BP64-00383B	KNOB-HOLDER	L6,ABS,HB,GRAY,SVM3012	1	S.N.A	
T0141	BP97-01013A	ASSY SMD-DIGITAL	HLR4667W1X/XAA,L64C,L6	1	S.N.A	
T0145	BP94-02049E	ASSY PCB MISC-ANALOG	HLR5067W1X,L64C,L6	1	S.A	
T0158	BP96-00937C	ASSY COVER P-MAIN	L6 ALL,HIPS, V0,GR503	1	S.A	
T0175	BP96-01278A	ASSY SPEAKER P	8ohm,L6(DLP)_VE,15W	2	S.A	
T0186	BP96-00964B	ASSY COVER P-GRILLE	46L6,HIPS,HB,GR503,S	1	S.A	
T0245	BP94-02140D	ASSY PCB MISC-KEY CONTROL	HLP5063W,L62B,	1	S.A	
T0260	BP67-00095A	MIRROR	MIRROR FRONT 46",GLASS,1005X530X5	1	S.A	
T0267	BP61-00936A	BRACKET-MIRROR TOP	46L6,AL6063 EXTR	1	S.N.A	
T0268	BP94-02140G	ASSY PCB MISC-RMC LED	HLP5063W,L62B,ATLA	1	S.A	
T0268	3903-000144	CBF-POWER CORD	DT,US,BP3/Y,U(IEC C13-RA)	1	S.A	
T0286	BP31-00019A	FAN-DC	F5010L12B2-RS WS,ROBOCOP/PBTP (UL	1	S.A	
T0514	BP61-00911A	BRACKET-SUPPORT	46L6,SECC-1,T1.6,NTR,BAC	2	S.N.A	
T0524	BP63-00404A	COVER-GRILLE	46L6,HIPS,HB,GR503,SV012P	1	S.N.A	
T0527	BP61-01045A	BRACKET-COVER	L6,SECC-1,T1.2,NTR,BOTTOM	1	S.N.A	
T0852	BP96-00967B	ASSY COVER P-MIDDLE	46L6,HIPS,HB,GR503,S	1	S.A	
T0890	BP96-00855A	ASSY FAN P	1B1S,50*50*0.5,1.9,0.19,24,-1	1	S.A	
T0903	BP61-00528A	HOLDER-DUST	50L3,HIPS HB,GRAY	2	S.N.A	
T0952	BP63-00294B	COVER DUST-ASSY	L6,HIPS,HB,GRAY	2	S.N.A	

4-2 HLR5067W1X/XAA

You can search for the updated part code through ITSELF web site.
 URL:<http://itself.sec.samsung.co.kr>

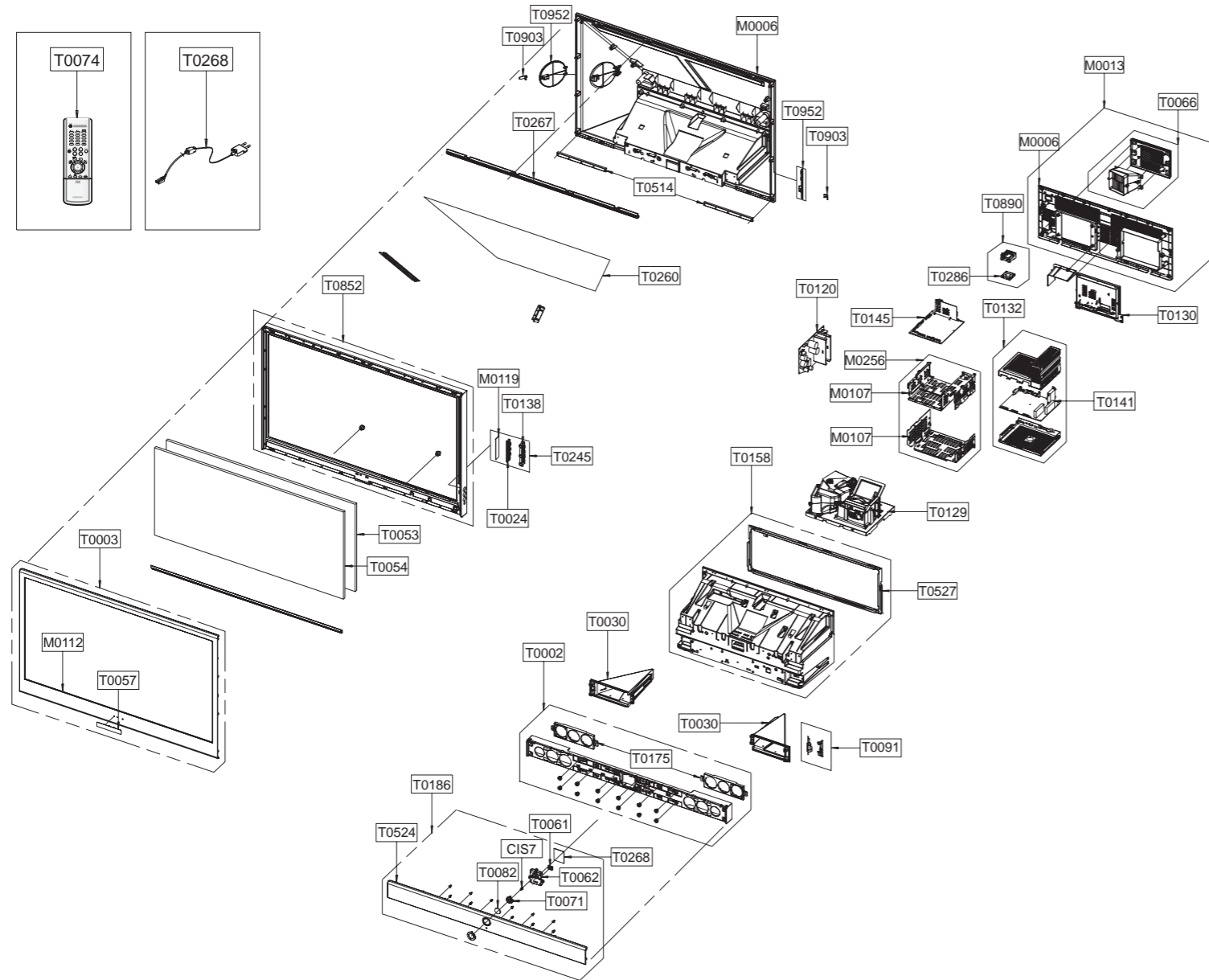

Loc. No.	Code No.	Description	Specification	Q'ty	SA/SNA	Remark
CIS7	AA61-60003J	SPRING ETC-CS	-,SUS304,-,OD6,N7,OD6,-,	1	S.N.A	
M0006	BP63-00410A	COVER-REAR	50L6,HIPS,HB,GR503,TOP	1	S.A	
M0006	BP63-00401A	COVER-REAR BOTTOM	50L6,HIPS,V0,GRAY	1	S.N.A	
M0013	BP96-00938C	ASSY COVER P-REAR BOTTOM	L6,HIPS V0,GR50	1	S.A	
M0107	BP61-00892A	BRACKET-PCB	50L3,SECC,T1.0,NTR,TOP(BUILT	1	S.N.A	
M0107	BP61-00893A	BRACKET-PCB	50L3,SECC,T1.0,NTR,BOT(BUILT	1	S.N.A	
M0112	BP63-00408A	COVER-FRONT	50L6,HIPS,HB,BLK,BKM1326R1,S	1	S.N.A	
M0119	BP41-00124B	PCB CONTROL	HLP5063W,FR-4,2L,A,1.6T,245	1	S.N.A	
M0256	BP96-00849F	ASSY BRACKET P-MAIN PCB	L3,L6,L7,SECC,T1	1	S.A	
T0002	BP96-00934B	ASSY COVER P-FRONT BOTTOM	50L6,HIPS HB,G	1	S.A	
T0003	BP96-00994B	ASSY COVER P-FRONT	50L6,SEA(L64A),HIPS H	1	S.A	
T0024	BP64-00384B	KNOB-FAMILY	L6,ABS,HB,GRAY,SVM-3012	1	S.N.A	
T0030	BP96-00942B	ASSY COVER P-SIDE	50L6,HIPS,HB,GR503,LEF	1	S.A	
T0030	BP96-00943B	ASSY COVER P-SIDE	50L6,HIPS,HB,GR503,RIG	1	S.A	
T0053	BP67-00140A	SCREEN FRESNEL	50W,1126*646,1.5T	1	S.A	
T0054	BP67-00137A	SCREEN LENTI	50W,1126*646,2.4T	1	S.A	
T0057	BP64-00177A	BADGE-BRAND	ALL,AL,T1.5,70,11.3,BLK,SILI	1	S.N.A	
T0061	BP64-00385A	WINDOW-REMOCON	50L3,PC,VIOLET	1	S.N.A	
T0062	BP61-00530A	HOLDER-POWER	50L3,HIPS HB,GRAY	1	S.N.A	
T0066	BP96-00535E	ASSY COVER P-DUCT	L6,HIPS HB,GRY	1	S.N.A	
T0071	BP64-00382A	INDICATOR-LED	50L3,ABS CLEAR (LG)	1	S.N.A	
T0074	BP59-00071B	REMOCON	HURRICANE, TM76A, 200*54*30, ZILOG	1	S.A	
T0082	BP64-00309B	WINDOW LED	50L3,ACRYL,2.0, half-mirror, SE	1	S.N.A	
T0091	BP94-02059C	ASSY PCB MISC-AV SIDE	HLR5067, L64B, L6	1	S.A	
T0120	BP94-02222H	ASSY PCB POWER	HLR5067(L6), L64C, 120V(POD	1	S.N.A	
T0129	BP96-01018J	ASSY ENGINE P-DLP	50L6(L620), AIR(elec), P	1	S.A	
T0130	BP96-00848E	ASSY COVER P-TERMINAL BOARD	L6, L64A, HIPS	1	S.A	
T0132	BP94-02084A	ASSY PCB MISC-DIGITAL	HLR4667W1X, L64C, L6	1	S.A	
T0138	BP64-00383B	KNOB-HOLDER	L6, ABS, HB, GRAY, SVM3012	1	S.N.A	
T0141	BP97-01013A	ASSY SMD-DIGITAL	HLR4667W1X/XAA, L64C, L6	1	S.N.A	
T0145	BP94-02049E	ASSY PCB MISC-ANALOG	HLR5067W1X, L64C, L6	1	S.A	
T0158	BP96-00937C	ASSY COVER P-MAIN	L6 ALL, HIPS, V0, GR503	1	S.A	
T0175	BP96-01278A	ASSY SPEAKER P	8ohm, L6(DLP)_VE, 15W	2	S.A	
T0186	BP96-00935B	ASSY COVER P-GRILLE	50L6, HIPS, HB, GR503,	1	S.A	
T0245	BP94-02140D	ASSY PCB MISC-KEY CONTROL	HLP5063W, L62B,	1	S.A	
T0260	BP67-00096A	MIRROR	MIRROR FRONT 50°, GLASS, 1100X580X5	1	S.A	
T0267	BP61-00910A	BRACKET-MIRROR TOP	50L6, AL6063 EXTR	1	S.N.A	
T0268	BP94-02140G	ASSY PCB MISC-RMC LED	HLP5063W, L62B, ATLA	1	S.A	
T0268	3903-000144	CBF-POWER CORD	DT, US, BP3/Y, U(IEC C13-RA)	1	S.A	
T0286	BP31-00019A	FAN-DC	F5010L12B2-RS WS, ROBOCOP, PBTP (UL	1	S.A	
T0514	BP61-00912A	BRACKET-SUPPORT	50L6, SECC-1, T1.6, NTR, BAC	2	S.N.A	
T0524	BP63-00412A	COVER-GRILLE	50L6, HIPS, HB, GR503, SV012P	1	S.N.A	
T0527	BP61-01045A	BRACKET-COVER	L6, SECC-1, T1.2, NTR, BOTTOM	1	S.N.A	
T0852	BP96-00936A	ASSY COVER P-MIDDLE	50L6, HIPS, HB, GR503, S	1	S.A	
T0890	BP96-00855A	ASSY FAN P	1B1S, 50°50'0.5, 1.9, 0.19, 24,-1	1	S.A	
T0903	BP61-00528A	HOLDER-DUST	50L3, HIPS HB, GRAY	2	S.N.A	
T0952	BP63-00294B	COVER DUST-ASSY	L6, HIPS, HB, GRAY	2	S.N.A	

4-3 HLR5667W1X/XAA

You can search for the updated part code through ITSELF web site.
 URL: <http://itself.sec.samsung.co.kr>

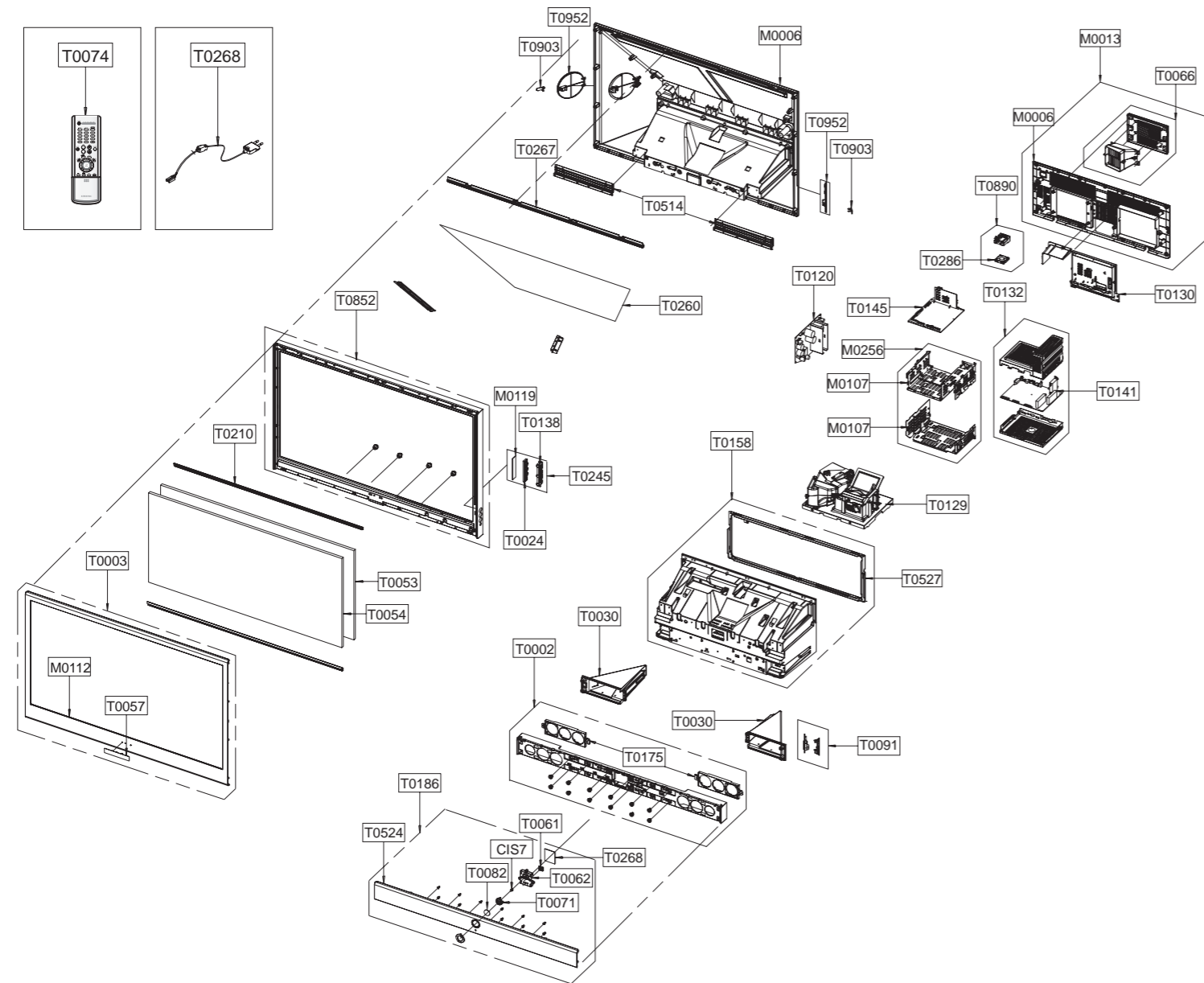

Loc. No.	Code No.	Description	Specification	Q'ty	SA/SNA	Remark
CIS7	AA61-60003J	SPRING ETC-CS	-.SUS304,-,OD6,N7,OD6,-,	1	S.N.A	
M0006	BP63-00417A	COVER-REAR	56L6,HIPS,HB,GRAY,TOP	1	S.A	
M0006	BP63-00401A	COVER-REAR BOTTOM	50L6,HIPS,V0,GRAY	1	S.N.A	
M0013	BP96-00938C	ASSY COVER P-REAR BOTTOM	L6,HIPS V0,GR50	1	S.A	
M0107	BP61-00892A	BRACKET-PCB	50L3,SECC,T1.0,NTR,TOP(BUILT	1	S.N.A	
M0107	BP61-00893A	BRACKET-PCB	50L3,SECC,T1.0,NTR,BOT(BUILT	1	S.N.A	
M0112	BP63-00415B	COVER-FRONT	56L6,HIPS,HB,BLK,BKM1326R1,S	1	S.N.A	
M0119	BP41-00124B	PCB CONTROL	HLP5063W,FR-4,2L,A,1.6T,245	1	S.N.A	
M0256	BP96-00849F	ASSY BRACKET P-MAIN PCB	L3,L6,L7,SECC,T1	1	S.A	
T0002	BP96-00962B	ASSY COVER P-FRONT BOTTOM	56L6,HIPS,HB,G	1	S.A	
T0003	BP96-00995B	ASSY COVER P-FRONT	56L6,SEA(L64A),HIPS H	1	S.A	
T0024	BP64-00384B	KNOB-FAMILY	L6,ABS,HB,GRAY,SVM-3012	1	S.N.A	
T0030	BP96-00973B	ASSY COVER P-SIDE	56L6,HIPS,HB,GR503,LEF	1	S.A	
T0030	BP96-00974B	ASSY COVER P-SIDE	56L6,HIPS,HB,GR503,RIG	1	S.A	
T0053	BP67-00184A	SCREEN FRESNEL	56W,1270*728,T1.5	1	S.A	
T0054	BP67-00183A	SCREEN LENTI	56W,1270*728,T2.5	1	S.A	
T0057	BP64-00178A	BADGE-BRAND	ALL,AL,T1.5,78,13.0,-,BLK,SIL	1	S.A	
T0061	BP64-00385A	WINDOW-REMOCON	50L3,PC,VIOLET	1	S.N.A	
T0062	BP61-00530A	HOLDER-POWER	50L3,HIPS HB,GRAY	1	S.N.A	
T0066	BP96-00535E	ASSY COVER P-DUCT	L6,HIPS HB,GRY	1	S.N.A	
T0071	BP64-00382A	INDICATOR-LED	50L3,ABS CLEAR (LG)	1	S.N.A	
T0074	BP59-00071B	REMOCON	HURRICANE, TM76A,200*54*30,ZILOG	1	S.A	
T0082	BP64-00309B	WINDOW LED	50L3,ACRYL,2.0,half-mirror,SE	1	S.N.A	
T0091	BP94-02059F	ASSY PCB MISC-AV SIDE	HLR5667,L64B,L6	1	S.A	
T0120	BP94-02222H	ASSY PCB POWER	HLR5067(L6),L64C,120V(POD	1	S.N.A	
T0129	BP96-01018K	ASSY ENGINE P-DLP	56L6(L620),Delta AIR,P	1	S.A	
T0130	BP96-00848E	ASSY COVER P-TERMINAL BOARD	L6,L64A,HIPS	1	S.A	
T0132	BP94-02084A	ASSY PCB MISC-DIGITAL	HLR4667W1X,L64C,L6	1	S.A	
T0138	BP64-00383B	KNOB-HOLDER	L6,ABS,HB,GRAY,SVM3012	1	S.N.A	
T0141	BP97-01013A	ASSY SMD-DIGITAL	HLR4667W1X/XAA,L64C,L6	1	S.N.A	
T0145	BP94-02049E	ASSY PCB MISC-ANALOG	HLR5067W1X,L64C,L6	1	S.A	
T0158	BP96-00937C	ASSY COVER P-MAIN	L6 ALL,HIPS, V0,GR503	1	S.A	
T0175	BP96-01278A	ASSY SPEAKER P	8ohm,L6(DLP)_VE,15W	2	S.A	
T0186	BP96-00965B	ASSY COVER P-GRILLE	56L6,HIPS,HB,GR503,S	1	S.A	
T0210	BP61-00984A	BRACKET-SCREEN TOP	56/61L6,AL6063 EXTR,T	1	S.N.A	
T0245	BP94-02140D	ASSY PCB MISC-KEY CONTROL	HLP5063W,L62B,	1	S.A	
T0260	BP67-00097A	MIRROR	Front Mirror 56*,GLASS,1279X650X6	1	S.A	
T0267	BP61-00913A	BRACKET-MIRROR TOP	56L6,AL6063 EXTR	1	S.N.A	
T0268	BP94-02140G	ASSY PCB MISC-RMC LED	HLP5063W,L62B,ATLA	1	S.A	
T0268	3903-000144	CBF-POWER CORD	DT,US,BP3Y,U(IEC C13-RA)	1	S.A	
T0286	BP31-00019A	FAN-DC	F5010L12B2-RS WS,ROBOCOP,PBTP (UL	1	S.A	
T0514	BP61-00914A	BRACKET-SUPPORT	56L6,SECC-1,T1.6,NTR,BAC	2	S.N.A	
T0524	BP63-00419A	COVER-GRILLE	56L6,HIPS,HB,GRAY	1	S.N.A	
T0527	BP61-01045A	BRACKET-COVER	L6,SECC-1,T1.2,NTR,BOTTOM	1	S.N.A	
T0852	BP96-00968B	ASSY COVER P-MIDDLE	56L6,HIPS,HB,GR503,S	1	S.N.A	
T0890	BP96-00855A	ASSY FAN P	1B1S,50*50*0.5,1.9,0.19,24,-1	1	S.A	
T0903	BP61-00528A	HOLDER-DUST	50L3,HIPS HB,GRAY	2	S.N.A	
T0952	BP63-00294B	COVER DUST-ASSY	L6,HIPS,HB,GRAY	2	S.N.A	

4-4 HLR6167W1X/XAA

You can search for the updated part code through ITSELF web site.
 URL: <http://itself.sec.samsung.co.kr>

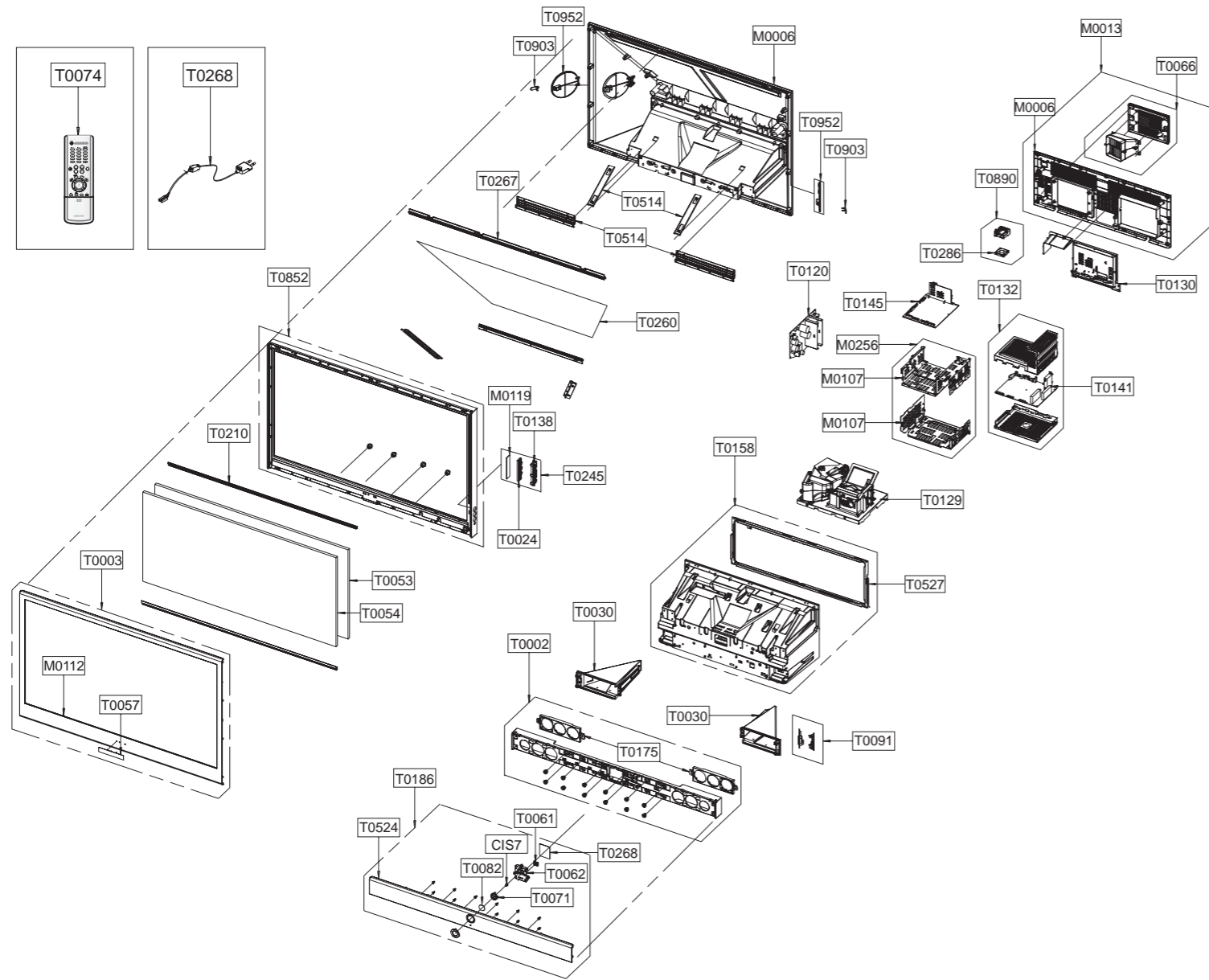

Loc. No.	Code No.	Description	Specification	Q'ty	SA/SNA	Remark
CIS7	AA61-60003J	SPRING ETC-CS	-.SUS304,-.OD6,N7,OD6,-.	1	S.N.A	
M0006	BP63-00424A	COVER-REAR	61L6,HIPS,HB,GRAY,TOP	1	S.A	
M0006	BP63-00401A	COVER-REAR BOTTOM	50L6,HIPS,V0,GRAY	1	S.N.A	
M0013	BP96-00938C	ASSY COVER P-REAR BOTTOM	L6,HIPS V0,GR50	1	S.A	
M0107	BP61-00892A	BRACKET-PCB	50L3,SECC,T1.0,NTR,TOP(BUILT	1	S.N.A	
M0107	BP61-00893A	BRACKET-PCB	50L3,SECC,T1.0,NTR,BOT(BUILT	1	S.N.A	
M0112	BP63-00422B	COVER-FRONT	61L6,HIPS,HB,BLK,BKM1326,SEA	1	S.N.A	
M0119	BP41-00124B	PCB CONTROL	HLP5063W,FR-4,2L,A,1.6T,245	1	S.N.A	
M0256	BP96-00849F	ASSY BRACKET P-MAIN PCB	L3,L6,L7,SECC,T1	1	S.A	
T0002	BP96-00963B	ASSY COVER P-FRONT BOTTOM	61L6,HIPS,HB,G	1	S.A	
T0003	BP96-00996B	ASSY COVER P-FRONT	61L6,SEA(L64A),HIPS H	1	S.A	
T0024	BP64-00384B	KNOB-FAMILY	L6,ABS,HB,GRAY,SVM-3012	1	S.N.A	
T0030	BP96-00975B	ASSY COVER P-SIDE	61L6,HIPS,HB,GR503,LEF	1	S.A	
T0030	BP96-00976B	ASSY COVER P-SIDE	61L6,HIPS,HB,GR503,RIG	1	S.A	
T0053	BP67-00165A	SCREEN FRESNEL	61W,1381*790,1.5T	1	S.A	
T0054	BP67-00164A	SCREEN LENTI	61W,1381*790,T2.5	1	S.A	
T0057	BP64-00178A	BADGE-BRAND	ALL,AL,T1.5,78,13.0.,BLK,SIL	1	S.A	
T0061	BP64-00385A	WINDOW-REMOCON	50L3,PC,VIOLET	1	S.N.A	
T0062	BP61-00530A	HOLDER-POWER	50L3,HIPS HB,GRAY	1	S.N.A	
T0066	BP96-00535E	ASSY COVER P-DUCT	L6,HIPS HB,GRY	1	S.N.A	
T0071	BP64-00382A	INDICATOR-LED	50L3,ABS CLEAR (LG)	1	S.N.A	
T0074	BP59-00071B	REMOCON	HURRICANE,TM76A,200*54*30,ZILOG	1	S.A	
T0082	BP64-00309B	WINDOW LED	50L3,ACRYL,2.0,half-mirror,SE	1	S.N.A	
T0091	BP94-02059F	ASSY PCB MISC-A/V SIDE	HLR5667,L64B,L6	1	S.A	
T0120	BP94-02222H	ASSY PCB POWER	HLR5067(L6),L64C,120V(POD	1	S.N.A	
T0129	BP96-01018L	ASSY ENGINE P-DLP	61L6(L620),Delta AIR,P	1	S.A	
T0130	BP96-00848E	ASSY COVER P-TERMINAL BOARD	L6,L64A,HIPS	1	S.A	
T0132	BP94-02084A	ASSY PCB MISC-DIGITAL	HLR4667W1X,L64C,L6	1	S.A	
T0138	BP64-00383B	KNOB-HOLDER	L6,ABS,HB,GRAY,SVM3012	1	S.N.A	
T0141	BP97-01013A	ASSY SMD-DIGITAL	HLR4667W1X/XAA,L64C,L6	1	S.N.A	
T0145	BP94-02049E	ASSY PCB MISC-ANALOG	HLR5067W1X,L64C,L6	1	S.A	
T0158	BP96-00937C	ASSY COVER P-MAIN	L6 ALL,HIPS, V0,GR503	1	S.A	
T0175	BP96-01278A	ASSY SPEAKER P	8ohm,L6(DLP)_VE,15W	2	S.A	
T0186	BP96-00966B	ASSY COVER P-GRILLE	61L6,HIPS,HB,GR503,S	1	S.A	
T0210	BP61-00984A	BRACKET-SCREEN TOP	56/61L6,AL6063 EXTR,T	1	S.N.A	
T0245	BP94-02140D	ASSY PCB MISC-KEY CONTROL	HLP5063W,L62B,	1	S.A	
T0260	BP67-00098A	MIRROR	FRONT MIRROR 61",GLASS,34.85MM,13	1	S.A	
T0267	BP61-00937A	BRACKET-MIRROR TOP	61L6,AL6063 EXTR	1	S.N.A	
T0268	BP94-02140G	ASSY PCB MISC-RMC LED	HLP5063W,L62B,ATLA	1	S.A	
T0268	3903-000144	CBF-POWER CORD	DT,US,BP3Y,U(IEC C13-RA)	1	S.A	
T0286	BP31-00019A	FAN-DC	F5010L12B2-RS WS,ROBOCOP,PBTP (UL	1	S.A	
T0514	BP61-00915A	BRACKET-SUPPORT	61L6,SECC-1,T1.2,NTR,BAC	2	S.N.A	
T0514	BP61-00918A	BRACKET-SUPPORT	61L6,SECC-1,T1.6,NTR	2	S.N.A	
T0524	BP63-00426A	COVER-GRILLE	61L6,HIPS,HB,GRAY	1	S.N.A	
T0527	BP61-01045A	BRACKET-COVER	L6,SECC-1,T1.2,NTR,BOTTOM	1	S.N.A	
T0852	BP96-00969B	ASSY COVER P-MIDDLE	61L6,HIPS,HB,GR503,S	1	S.N.A	
T0890	BP96-00855A	ASSY FAN P	1B1S,50*50*0.5,1.9,0.19,24,-1	1	S.A	
T0903	BP61-00528A	HOLDER-DUST	50L3,HIPS HB,GRAY	2	S.N.A	
T0952	BP63-00294B	COVER DUST-ASSY	L6,HIPS,HB,GRAY	2	S.N.A	

4-5 L620 Engine Ass'y

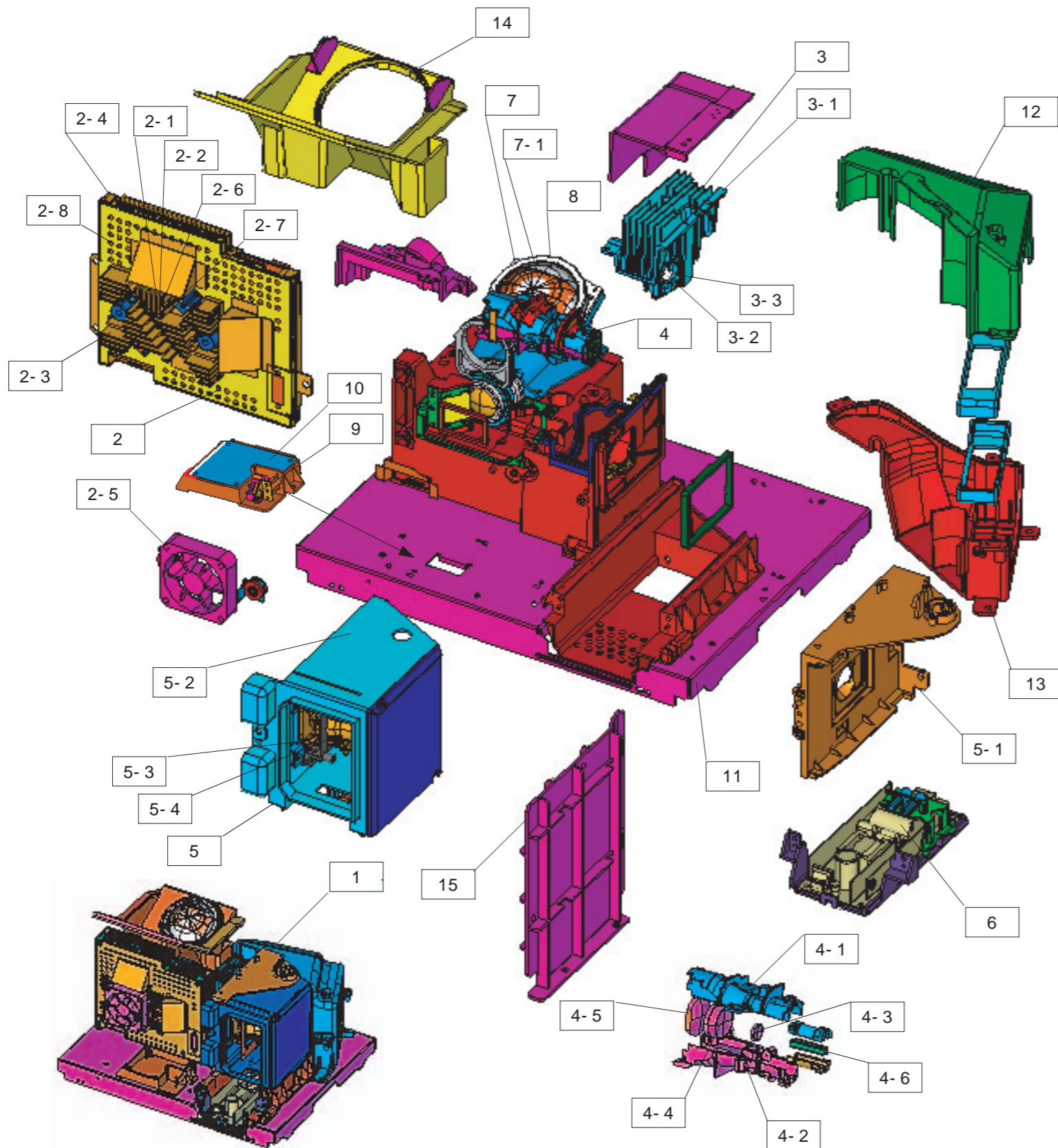

L620 Engine Exploded View List						
No.	Loc. No.	Code No.	Description	Specification	Q'ty	SA/SNA
1		BP96-01105A	ASSY ENGINE P-DLP	42L6,PHILIPS 120W,SVC ENGINE	1	S.A
2		BP96-01102A	ASSY DMD BOARD P	L6 Philips,DMD BOARD,SERVICE	1	S.N.A
2-1		BP61-01023A	HOLDER-CLAMP DMD	SVP-50L6HR,MG,T2.5,D/C	1	S.N.A
2-2	T0212	BP61-01010A	BRACKET-PANEL	SVP-50L6HR,AL D/C,T3.0	1	S.N.A
2-3		BP61-01028A	BRACKET-COOLER	SVP-50L6HR,AL,T3.0	1	S.N.A
2-4		BP63-00509A	SHIELD CASE-DMD(F)	SVP-50L6HR,SECC,T1.0	1	S.N.A
2-5	T0286	BP31-00011A	FAN-DC	AD0612LB-D72GL,P.B.T UL94-Vo,Wire	1	S.A
2-6	T0268	4719-001962	DLP	1280x720D/HD4,FTP,DMD TYPE A/NON ape	1	S.A
2-7		BP61-01031A	HOLDER-SOCKET DMD	LCP,T3.0,BLACK,203pin	1	S.N.A
2-8	T0027	BP94-02220A	ASSY PCB S-DMD	L620,HURRICANE	1	S.N.A
3		BP96-01103A	ASSY COLOR WHEEL P	L6,SERVICE	1	S.N.A
3-1		BP61-01024A	HOLDER-COLOR WHEEL	SVP-50L6HR,MG,T2.5,D/	1	S.N.A
3-2	T0593	BP64-00475A	GLASS-COLOR WHEEL	65mm NDF,FLOAT GLASS,T	1	S.N.A
3-3		BP67-00208A	GLASS-UV FILTER	HURRICANE,GLASS,NTR,16.5	1	S.N.A
4		BP96-01104A	ASSY LENS P-ILLUMINATION	L6,SERVICE	1	S.N.A
4-1		BP61-01021A	HOLDER-L/T(TOP)	SVP-50L6HR,PPS G/F30,T2.	1	S.N.A
4-2		BP61-01022A	HOLDER-L/T(BOT)	SVP-50L6HR,PPS G/F30	1	S.N.A
4-3		BP67-00211A	LENS-ILL E1	HURRICANE,NBFD13,NTR,R1=-28.	1	S.N.A
4-4		BP67-00212A	LENS-ILL E2/E3	HURRICANE,FD60,BACD5,NTR,	1	S.N.A
4-5		BP67-00213A	LENS-ILL E4	HURRICANE,BACED5,NTR,R1=54.5	1	S.N.A
4-6	T0134	BP67-00209A	MIRROR-LIGHT TUNNEL	HURRICANE,GLASS,3.5x	1	S.N.A
5		BP96-01073A	ASSY LAMP P	L6 NEW,PHILIPS 120W,E22	1	S.N.A
5-1		BP61-00726A	HOUSING-LAMP,BOTTOM 23	SVP-50L3HR,AL D/	1	S.N.A
5-2		BP61-01025A	HOLDER-HOUSING LAMP	SVP-50L6HR,PPS G/F30	1	S.N.A
5-3		BP61-00585A	HOLDER-LAMP F	DLP L3,AL D/C	1	S.N.A
5-4		BP47-00018A	LAMP	UHP 100W/120W 1.0,E22,65*70	1	S.N.A
6	T0049	BP47-00021A	LAMP-BALLAST	EUC 120 P/H11,120W,130mm ca	1	S.A
7		BP67-00207A	LENS-P/J ASSY	HURRICANE,GLASS,NTR,FOV=93	1	S.N.A
7-1		BP67-00223A	LENS-PROJECTION	PMMA,NTR,R1:114.50, R2:27.754,T4,ASP LENS	1	S.N.A
8		BP64-00541A	GLASS-ACTUATOR	MIRROR,T3.1,27,24,VCM	1	S.N.A
9		BP91-00775A	ASSY MISC-DETECTOR S/W	HLP5063WX/XAA,L62	1	S.N.A
10		BP94-02221A	ASSY PCB S-DETECTOR B/D	L620,HURRICANE	1	S.N.A
11		BP61-01014A	BRACKET-ENGINE BASE	SVP-50L6HR,SECC,T1.6	1	S.N.A
12		BP63-00516A	COVER-DUCT TOP	SVP-50L6HR,PC G/F20,T3.0	1	S.N.A
13		BP63-00517A	COVER-DUCT BOT	SVP-50L6HR,PC G/F20,T3.0	1	S.N.A
14		BP63-00505A	COVER-P/J LENS	SVP-50LLHR,ABS,T2.5	1	S.N.A
15	T0530	BP63-00537A	COVER-LAMP	HURRICANE 720P,PC	1	S.N.A

5. Electrical Part List

5-1 HLR4667W1X/XAA Service Item

You can search for the updated part code through ITSELF web site.

URL:<http://itself.sec.samsung.co.kr>

Loc. No.	Code No.	Description	Specification	Q'ty	SA/SNA	Remark
CIS3	BN40-00059A	TUNER	DNVD355BV401A, DNVD355BV401A, NTSC/Q	1	S.A	
M0013	BP96-00938B	ASSY COVER P-REAR BOTTOM	L6, HIPS V0, GR50	1	S.A	
M0018	BP97-00826A	ASSY MICOM	, L62B, 29W800D, T-ATLOSMWWS-100	1	S.A	
M0125	BP39-00106C	CBF SIGNAL-DVI(D)	HLP5063WX, 24P/24P, 2027	1	S.A	
T0002	BP96-00961B	ASSY COVER P-FRONT BOTTOM	46L6, HIPS, HB, G	1	S.A	
T0003	BP96-00993B	ASSY COVER P-FRONT	46L6, SEA(L64B), HIPS H	1	S.A	
T0030	BP96-00970B	ASSY COVER P-SIDE	46L6, HIPS, HB, GR503, LEF	1	S.A	
T0030	BP96-00971B	ASSY COVER P-SIDE	46L6, HIPS, HB, GR503, RIG	1	S.A	
T0049	BP47-00012A	LAMP-BALLAST	0.4A, 135W, 380V DC	1	S.A	
T0074	BP59-00071B	REMOCON	HURRICANE, TM76A, 200*54*30, ZILOG	1	S.A	
T0091	BP94-02059C	ASSY PCB MISC-A/V SIDE	HLR5067, L64B, L6	1	S.A	
T0120	BP94-02222H	ASSY PCB POWER	HLR5067(L6), L64C, 120V(POD)	1	S.N.A	
T0128	BN39-00518B	CBF SIGNAL-STEREO	SVP-50L3HR, 1P, UL2464#2	1	S.A	
T0129	BP96-00824C	ASSY ENGINE P-DLP	46L6, OSRAM 120W, E23, OM	1	S.A	
T0132	BP94-02084A	ASSY PCB MISC-DIGITAL	HLR4667W1X, L64C, L6	1	S.A	
T0145	BP94-02049E	ASSY PCB MISC-ANALOG	HLR5067W1X, L64C, L6	1	S.A	
T0158	BP96-00937C	ASSY COVER P-MAIN	L6 ALL, HIPS, V0, GR503	1	S.A	
T0175	BP96-01278A	ASSY SPEAKER P	8ohm, L6(DLP)_VE, 15W	2	S.A	
T0186	BP96-00964B	ASSY COVER P-GRILLE	46L6, HIPS, HB, GR503, S	1	S.A	
T0245	BP94-02140D	ASSY PCB MISC-KEY CONTROL	HLP5063W, L62B,	1	S.A	
T0268	BP94-02140G	ASSY PCB MISC-RMC LED	HLP5063W, L62B, ATLA	1	S.A	
T0703	BP96-00678E	ASSY DMD BOARD P	L3 Osram, DMD BOARD, DMD	1	S.A	
T0751	BP96-00852A	ASSY BALLAST P	L3 OSRAM, SERVICE BALLST	1	S.A	
T0753	BP94-02149K	ASSY PCB S-ACTUATOR	DP, BP41-00121A, L62B,	1	S.A	
T0888	BP96-00823A	ASSY LAMP P	L3, LAMP SERVICE, OSRAM 120W, E	1	S.A	
T0889	BP96-00674A	ASSY COLOR WHEEL P	SVP-50L3HR	1	S.A	
T0890	BP96-00855A	ASSY FAN P	1B1S, 50*50*0.5, 1.9, 0.19, 24, -1	1	S.A	
T0952	BP59-00087A	MODULE	UMX-NT-038, 2IN/2OUT OOB, 54-806j×?,	1	S.A	

5-2 HLR5067W1X/XAA Service Item

You can search for the updated part code through ITSELF web site.

URL:<http://itself.sec.samsung.co.kr>

Loc. No.	Code No.	Description	Specification	Q'ty	SA/SNA	Remark
CIS3	BN40-00059A	TUNER	DNVD355BV401A, DNVD355BV401A, NTSC/Q	1	S.A	
M0013	BP96-00938C	ASSY COVER P-REAR BOTTOM	L6, HIPS V0, GR50	1	S.A	
M0018	BP97-00955A	ASSY MICOM	L64C, 29W800D, T-HU2MWWP-1001,0	1	S.A	
M0045	BP96-01289A	ASSY ACCESSORY	HLR5067/XAA, L64B, L6	1	S.A	
M0125	BP39-00106C	CBF SIGNAL-DVI(D)	HLP5063WX, 24P/24P, 2027	1	S.A	
T0002	BP96-00934B	ASSY COVER P-FRONT BOTTOM	50L6, HIPS HB, G	1	S.A	
T0003	BP96-00994B	ASSY COVER P-FRONT	50L6, SEA(L64A), HIPS H	1	S.A	
T0010	BP96-00940A	ASSY HOLDER P-MIRROR LEFT	L6 ALL, L8, HIP	1	S.A	
T0010	BP96-00941A	ASSY HOLDER P-MIRROR RIGHT	L6 ALL, L8, HI	1	S.A	
T0030	BP96-00942B	ASSY COVER P-SIDE	50L6, HIPS, HB, GR503, LEF	1	S.A	
T0030	BP96-00943B	ASSY COVER P-SIDE	50L6, HIPS, HB, GR503, RIG	1	S.A	
T0049	BP47-00021A	LAMP-BALLAST	EUC 120 P/H11, 120W, 130mm ca	1	S.A	
T0053	BP67-00140A	SCREEN FRESNEL	50W, 1126*646, 1.5T	1	S.A	
T0054	BP67-00137A	SCREEN LENTI	50W, 1126*646, 2.4T	1	S.A	
T0074	BP59-00071B	REMOCON	HURRICANE, TM76A, 200*54*30, ZILOG	1	S.A	
T0091	BP94-02059C	ASSY PCB MISC-A/V SIDE	HLR5067, L64B, L6	1	S.A	
T0120	BP94-02222H	ASSY PCB POWER	HLR5067(L6), L64C, 120V(POD)	1	S.N.A	
T0128	BN39-00518B	CBF SIGNAL-STEREO	SVP-50L3HR, 1P, UL2464#2	1	S.A	
T0129	BP96-01018J	ASSY ENGINE P-DLP	50L6(L620), AIR(elec), P	1	S.A	
T0132	BP94-02084A	ASSY PCB MISC-DIGITAL	HLR4667W1X, L64C, L6	1	S.A	
T0145	BP94-02049E	ASSY PCB MISC-ANALOG	HLR5067W1X, L64C, L6	1	S.A	
T0175	BP96-01278A	ASSY SPEAKER P	8ohm, L6(DLP)_VE, 15W	2	S.A	
T0260	BP67-00096A	MIRROR	MIRROR FRONT 50", GLASS, 1100X580X5	1	S.A	
T0703	BP96-01102A	ASSY DMD BOARD P	L6 Philips, DMD BOARD, SE	1	S.A	
T0888	BP96-01073A	ASSY LAMP P	L6, L8 (L620, L680) , - 61 INCH	1	S.A	
T0889	BP96-01103A	ASSY COLOR WHEEL P	L6, SERVICE	1	S.A	
T0890	BP96-00855A	ASSY FAN P	1B1S, 50*50*0.5, 1.9, 0.19, 24, -1	1	S.A	
T0952	BP59-00087A	MODULE	UMX-NT-038, 2IN/2OUT OOB, 54-806j×?,	1	S.A	

5-3 HLR5667W1X/XAA Service Item

You can search for the updated part code through ITSELF web site.

URL:<http://itself.sec.samsung.co.kr>

Loc. No.	Code No.	Description	Specification	Q'ty	SA/SNA	Remark
CIS3	BN40-00059A	TUNER	DNVD355BV401A, DNVD355BV401A, NTSC/Q	1	S.A	
M0013	BP96-00938C	ASSY COVER P-REAR BOTTOM	L6, HIPS V0, GR50	1	S.A	
M0018	BP97-00955A	ASSY MICOM	L64C, 29W800D, T-HU2MWWP-1001,0	1	S.A	
M0125	BP39-00106C	CBF SIGNAL-DVI(D)	HLP5063WX, 24P/24P, 2027	1	S.A	
T0002	BP96-00962B	ASSY COVER P-FRONT BOTTOM	56L6, HIPS, HB, G	1	S.A	
T0003	BP96-00995B	ASSY COVER P-FRONT	56L6, SEA(L64A), HIPS H	1	S.A	
T0049	BP47-00021A	LAMP-BALLAST	EUC 120 P/H11, 120W, 130mm ca	1	S.A	
T0074	BP59-00071B	REMOCON	HURRICANE, TM76A, 200*54*30, ZILOG	1	S.A	
T0091	BP94-02059F	ASSY PCB MISC-A/V SIDE	HLR5667, L64B, L6	1	S.A	
T0120	BP94-02222H	ASSY PCB POWER	HLR5067(L6), L64C, 120V(POD)	1	S.N.A	
T0128	BN39-00518B	CBF SIGNAL-STEREO	SVP-50L3HR, 1P, UL2464#2	1	S.A	
T0129	BP96-01018K	ASSY ENGINE P-DLP	56L6(L620), Delta AIR, P	1	S.A	
T0132	BP94-02084A	ASSY PCB MISC-DIGITAL	HLR4667W1X, L64C, L6	1	S.A	
T0145	BP94-02049E	ASSY PCB MISC-ANALOG	HLR5067W1X, L64C, L6	1	S.A	
T0175	BP96-01278A	ASSY SPEAKER P	8ohm, L6(DLP)_VE, 15W	2	S.A	
T0703	BP96-01102A	ASSY DMD BOARD P	L6 Philips, DMD BOARD, SE	1	S.A	
T0888	BP96-01073A	ASSY LAMP P	L6, L8 (L620, L680) , ~ 61 INCH	1	S.A	
T0889	BP96-01103A	ASSY COLOR WHEEL P	L6, SERVICE	1	S.A	
T0890	BP96-00855A	ASSY FAN P	1B1S, 50*50*0.5, 1.9, 0.19, 24, -1	1	S.A	
T0952	BP59-00087A	MODULE	UMX-NT-038, 2IN/2OUT OOB, 54-806 _i ×?,	1	S.A	

5-4 HLR6167W1X/XAA Service Item

You can search for the updated part code through ITSELF web site.

URL:<http://itself.sec.samsung.co.kr>

Loc. No.	Code No.	Description	Specification	Q'ty	SA/SNA	Remark
CIS3	BN40-00059A	TUNER	DNVD355BV401A, DNVD355BV401A, NTSC/Q	1	S.A	
M0003	BP96-00990A	ASSY COVER P-STAND	61L6, HIPS, HB, GR503, SV	1	S.A	
M0013	BP96-00938C	ASSY COVER P-REAR BOTTOM	L6, HIPS V0, GR50	1	S.A	
M0018	BP97-00955A	ASSY MICOM	L64C, 29W800D, T-HU2MWWP-1001,0	1	S.A	
M0045	BP96-01289A	ASSY ACCESSORY	HLR5067/XAA, L64B, L6	1	S.A	
M0125	BP39-00106C	CBF SIGNAL-DVI(D)	HLP5063WX, 24P/24P, 2027	1	S.A	
T0002	BP96-00963B	ASSY COVER P-FRONT BOTTOM	61L6, HIPS, HB, G	1	S.A	
T0003	BP96-00996B	ASSY COVER P-FRONT	61L6, SEA(L64A), HIPS H	1	S.A	
T0030	BP96-00975B	ASSY COVER P-SIDE	61L6, HIPS, HB, GR503, LEF	1	S.A	
T0030	BP96-00976B	ASSY COVER P-SIDE	61L6, HIPS, HB, GR503, RIG	1	S.A	
T0049	BP47-00021A	LAMP-BALLAST	EUC 120 P/H11, 120W, 130mm ca	1	S.A	
T0074	BP59-00071B	REMOCON	HURRICANE, TM76A, 200*54*30, ZILOG	1	S.A	
T0091	BP94-02059F	ASSY PCB MISC-A/V SIDE	HLR5667, L64B, L6	1	S.A	
T0120	BP94-02222H	ASSY PCB POWER	HLR5067(L6), L64C, 120V(POD	1	S.N.A	
T0128	BN39-00518B	CBF SIGNAL-STEREO	SVP-50L3HR, 1P, UL2464#2	1	S.A	
T0129	BP96-01018L	ASSY ENGINE P-DLP	61L6(L620), Delta AIR, P	1	S.A	
T0132	BP94-02084A	ASSY PCB MISC-DIGITAL	HLR4667W1X, L64C, L6	1	S.A	
T0145	BP94-02049E	ASSY PCB MISC-ANALOG	HLR5067W1X, L64C, L6	1	S.A	
T0175	BP96-01278A	ASSY SPEAKER P	8ohm, L6(DLP)_VE, 15W	2	S.A	
T0703	BP96-01102A	ASSY DMD BOARD P	L6 Philips, DMD BOARD, SE	1	S.A	
T0888	BP96-01073A	ASSY LAMP P	L6, L8 (L620, L680) , - 61 INCH	1	S.A	
T0889	BP96-01103A	ASSY COLOR WHEEL P	L6, SERVICE	1	S.A	
T0890	BP96-00855A	ASSY FAN P	1B1S, 50*50*0.5, 1.9, 0.19, 24, -1	1	S.A	
T0952	BP59-00087A	MODULE	UMX-NT-038, 2IN/2OUT OOB, 54-806j×?,	1	S.A	

6. Troubleshooting

6-1 Checkpoints by Error Mode

- 1. Power Light: Check the master switch (ON/OFF) and the fuse to see if they are operating.
- 2. LED Blinking: See the basic LED checklist in 6-2-1

< Blinking Temp & Timer LED >

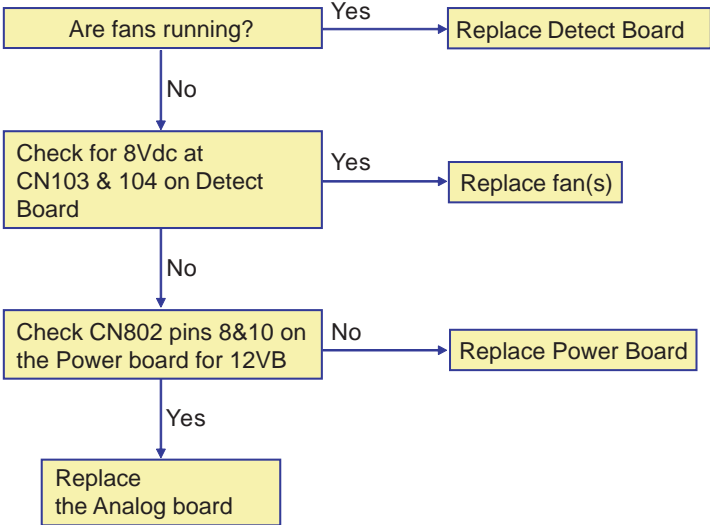

< Blinking Lamp and Temp LEDs >

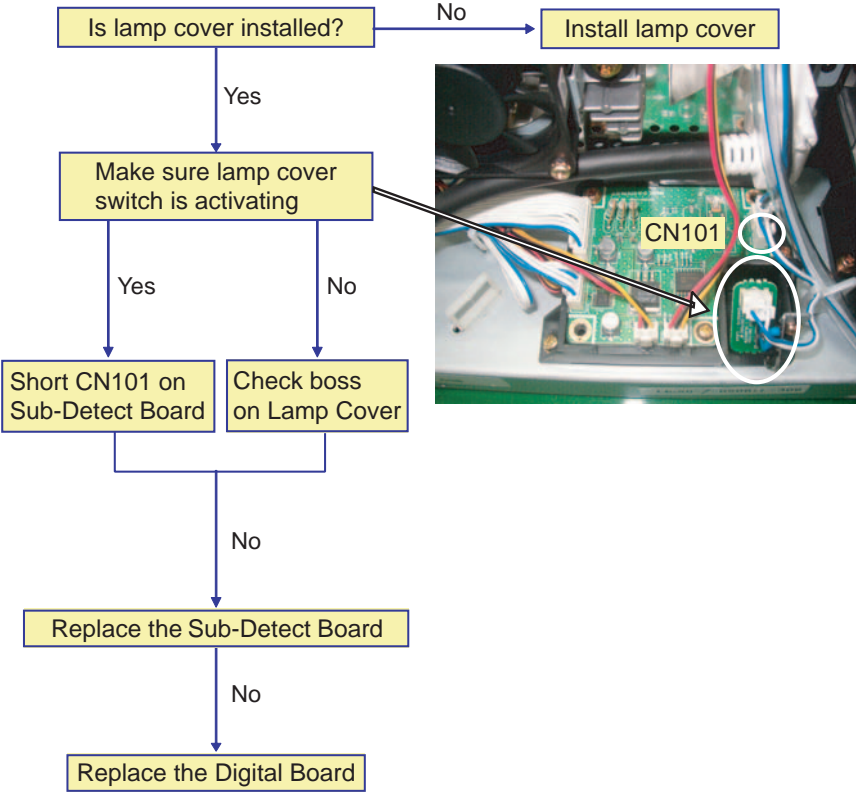

< Blinking Temp LED >

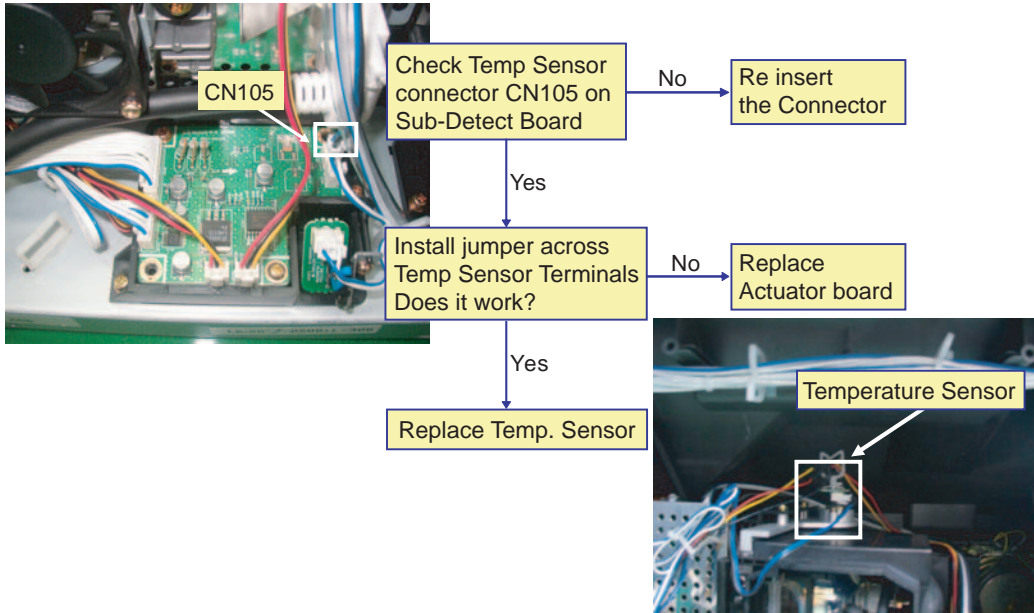

A blinking lamp LED is the most common failure indication. It can be caused by no lamp, no color wheel, no fan(s), or other defective components.

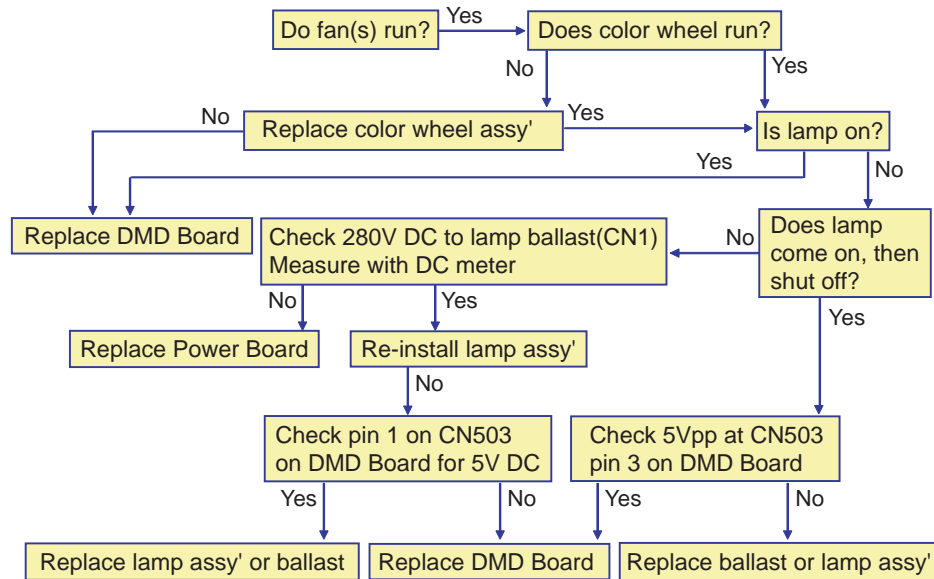

3. Noise:

Internal noise may be caused by a foreign substance on the fan or driving device.

For a DLP TV, the lamp fan, DMD board fan and color wheel are vulnerable to noise. Sometimes the connector wire around the lamp or DMD fan makes contact with the fan, while the color wheel is protected inside the module and cannot make contact with any nearby wires. However the color wheel sensor or the drive motor may cause noise by making contact with the color wheel.

As the color wheel uses an air bearing system, it has a very slight possibility of creating internal noise.

Sometimes outworn transistors may cause noise when regular noise occurs for other reasons than the fan itself. When irregular noise occurs for no particular reason, check the inside of the TV for any foreign substances.

The DLP projection TV may cause noise as the physical screen is empty inside, causing a resonance to a particular frequency. Thus a low vibration is not a malfunction.

Any 'creaking' noise is mostly from the structure of the device itself. A short, harsh noise may occur from a distortion or malformation due to thermal expansion between the metal joints, screws and loaded parts, respectively. Any intermittent 'creaking' noise can be removed by loosening the screws.

4. Black Screen (Voice Output):

Check the lamp/ballast of the replacement and, if there is nothing wrong, check the array resistance RA701-RA704 for the wave form or look into the connector joint areas as described in the manual (p.6-1).

When the measurement is not +- 25v, DDP1011 is in error. In conclusion, you should replace the DMD board.

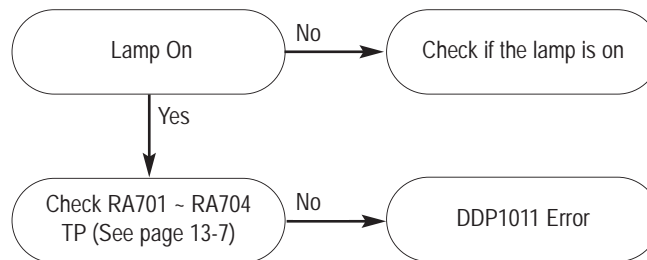

5. A black screen with the lamp on: Replace the DMD board.

6. Line Pattern: Regular line patterns occur vertically or horizontally: Replace the DMD board.

7. Voice Distortion: Replace the analog board.

8. Outside Light: This is not a product malfunction, but a possible installation or human error. This occurs when the projected light from the surrounding illumination reflects onto the screen. This disappears as the TV starts operating and the TV lamp gets brighter. However, you can avoid outside light by changing the position of the TV or the installation angle. Decreasing the illumination or changing the indoor lighting may work.

9. Screen Flip-over:

Enter Factory mode in DDP1011 and perform H-Flip (flip horizontally) and V-Flip (flip vertically).

The screen will flip over horizontally or vertically.

10. Other Screen Errors:



- ▶ 40 Vertical lines 16 pixels wide:
DDP1011 or BGA, DMD panel interference.
→ Replace the DMD board

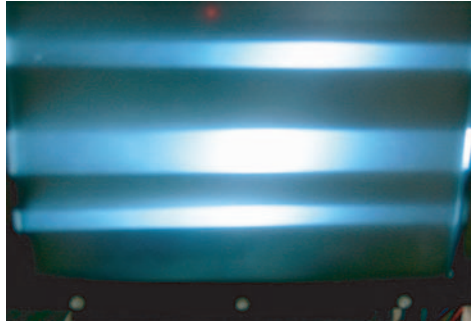

- ▶ Horizontal Bar or No Raster:
Error in DDP1011 or the DMP panel.
→ Replace the DMD board



- ▶ Dotted Vertical Bar:
Error in Rambus Dram(IC 403) or the soldering
→ Replace the DMD board

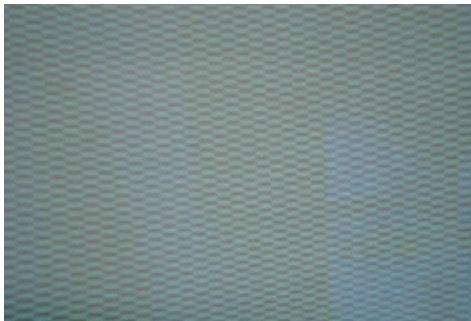

- ▶ Beehive mosaic patterns all over the screen:
Error in the LVDS Receiver (IC 601) or the soldering
The H sync signals are not transferred to DDP1011.
→ Replace the DMD board.

6-1-1 Video Circuit Error Checking

■ Basics:

- The DDP1011 on the DMD board has a feature to display internal test patterns.
- DN1e, which is an end port in the digital board, has a feature to display internal test patterns.
- The analog board sends signals to ADV7401 on the digital board.
- The analog board is the first output and the digital board is the second one, followed by DMD, which is the final one.

■ Diagnosis By Module

1. Access Service Mode

(In Standby mode, press "Mute", "1", "8", "2" and "Power" to turn the screen on and enter service mode)

2. Check if there is an error in the DMD board

DDP1011 → TEST PATTERN → Press the right arrow key:

Options of FULL WHITE, BLACK, RED, GREEN and BLUE PATTERN are displayed on the screen.

If "Pattern" does not appear, this is a DMD board error.

3. Check if there is an error in the digital board before the DMD.

When the DMD board has been determined to be error free based on the test patterns:

FACTORY MODE → DN1e → TEST PATTERN normal display: no error in the digital board.

If "Pattern" does not appear, it may be from a DMD board or ATI error or there is an analog board malfunction.

4. Check if there is an error in the analog board.

Check for a power signal from the analog to the digital boards. (See the circuit diagram below).

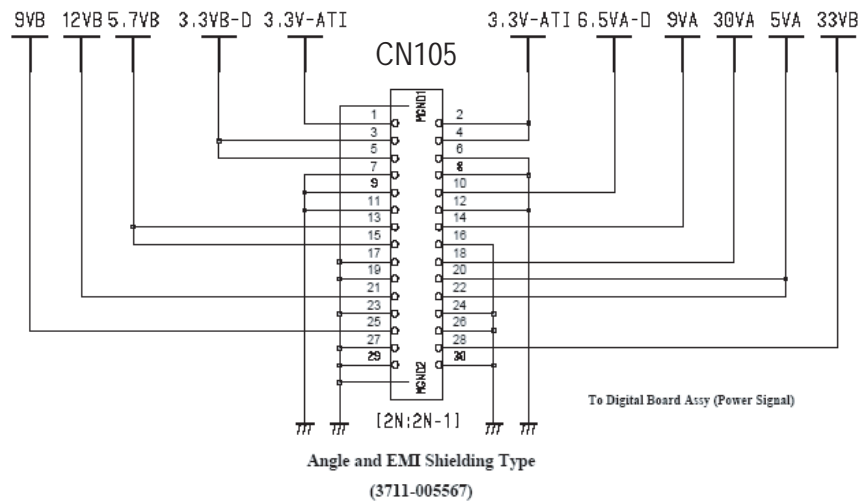

6-1-2 Flow Chart for Malfunction

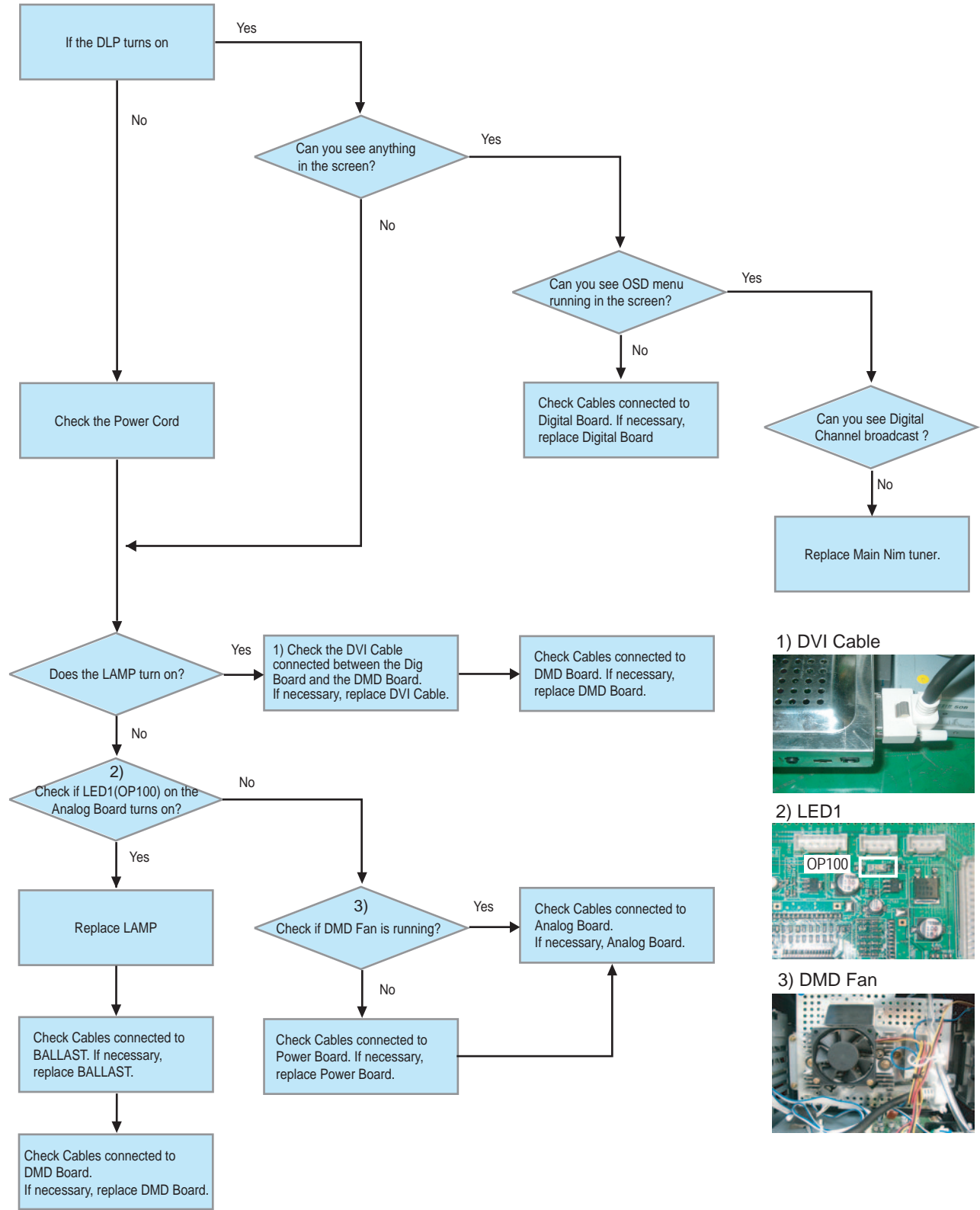

1) DVI Cable

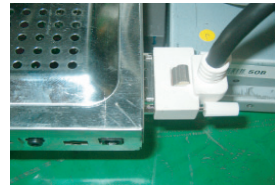

2) LED1

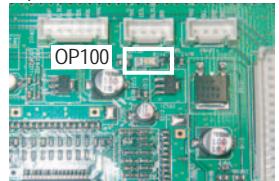

3) DMD Fan

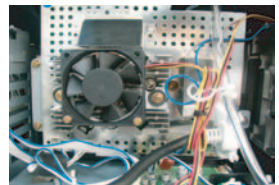

6-2 Troubleshooting Procedures by Error Modes

6-2-1 Installation & Connection

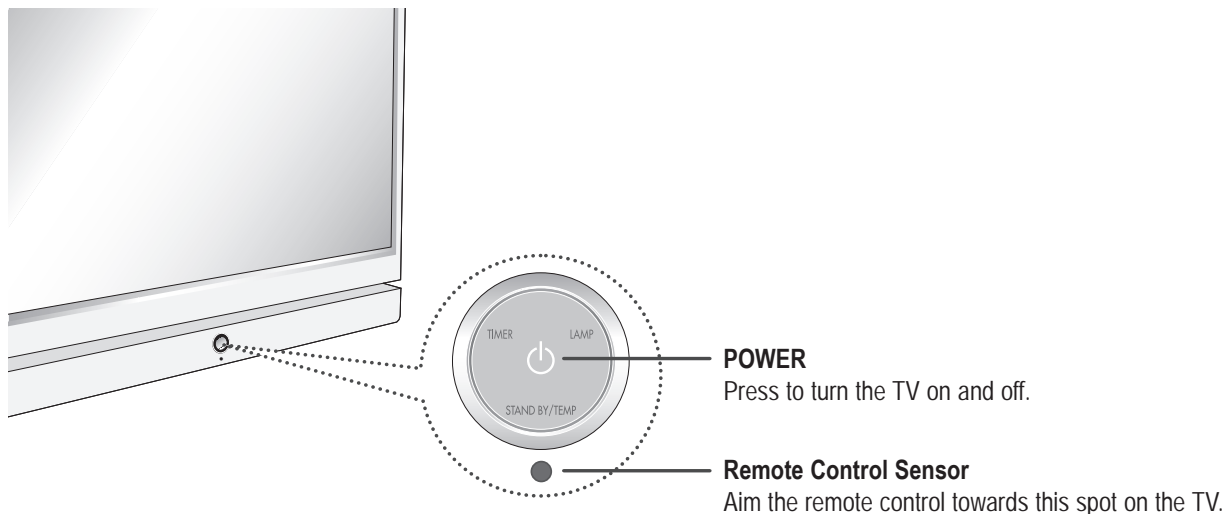

- : Light is On
- ◐ : Light is Blinking
- : Light is Off

TIMER	LAMP	STAND BY/TEMP	Indication
○	○	●	Standby state.
○	◐	○	The picture will automatically appear in about 15 seconds.
●	◐	○	Auto Timer ON/OFF has been set and the set will automatically be turned on in about 25 seconds.
◐	○	◐	A cooling fan inside the set is not operating normally.
○	◐	◐	Lamp cover on rear of the set is not properly shut.
○	○	◐	Check if the ventilation hole on the rear of the set is blocked, because if the inner temperature is too high, the power will shut off.
◐	◐	◐	Lamp may be defective.

- * It takes about 30 seconds for the TV to warm up, so normal brightness may not appear immediately.
- * The TV has a fan to keep the inside lamp from overheating. You'll occasionally hear it working.

6-2-2 Protect Status

1. When the rear cover is opened

A sensor detects when the rear cover is opened and turns the set off and then into Standby mode.

If you close the cover or fix the switch, you can turn the set on by pressing the Power button on the unit or the remote control.

The set will then operate normally.

2. When the temperature sensor operates

When the set is overheated, the internal temperature sensor turns the set off and the set goes to Standby mode.

When the internal temperature of the set returns to a normal range, turn the power on by pressing the Power button on the unit or the remote control. The set will then operate normally.

3. Attempting to turn the lamp on fails repeatedly

If turning the lamp on fails, the set automatically tries turning the lamp on 3 times. If all attempts fail, all LED's on the front panel will blink. Check the lamp and the ballast and replace them, if necessary.

6-2-3 Troubleshooting by the Checksum

Using Checksum to determine an error is neither reliable nor convenient.

The checksum can only be used effectively during a S/W service repair.

The checksum will be the same if the S/W version loaded into the TV is the same.

As programs of the same version have the same checksum value, you can determine if the program has been properly downloaded if you know the checksum of the version.

The following is required:

Factory Mode → Checksum → right button → checksum calculation → checksum output (ex: 0xab2b)

■ Examples

T_ROBOAKR1_1010 : Checksum = 0xab2b

T_ROBOAKR1_1014 : Checksum = 0x4faa

6-3 Troubleshooting Procedures by ASS'Y

6-3-1 Check Lamp & Ballast

1. When the lamp is not on, check if there is anything wrong with the ballast.

Remove the lamp. Fix the safety switch on the right with tape and turn on the power. Check to see if a blue flame starts igniting in the arc gap inside the ballast momentarily during start-up. There is no problem with the ballast if there is a flame. When the ballast has no error, replace the lamp.

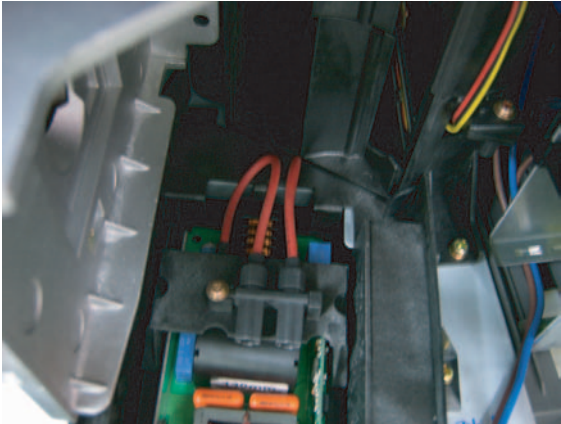

A blue flame occurs momentarily during start-up.

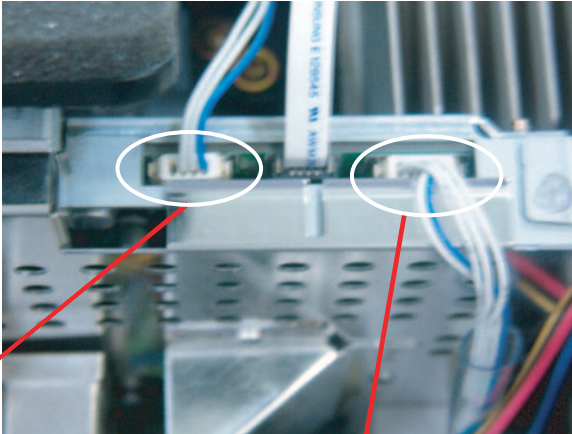
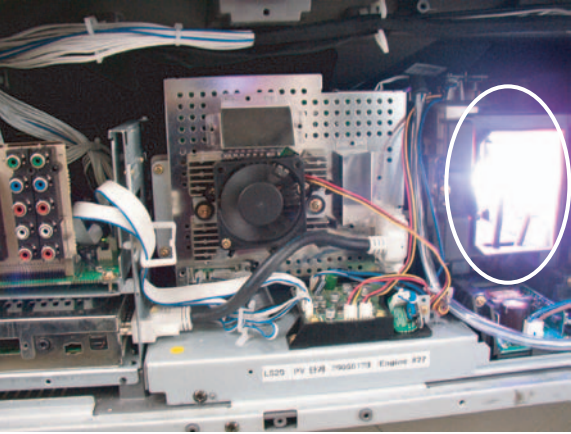
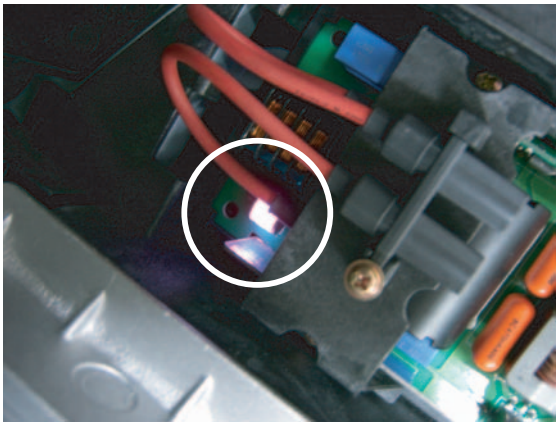

3.5V 180Hz

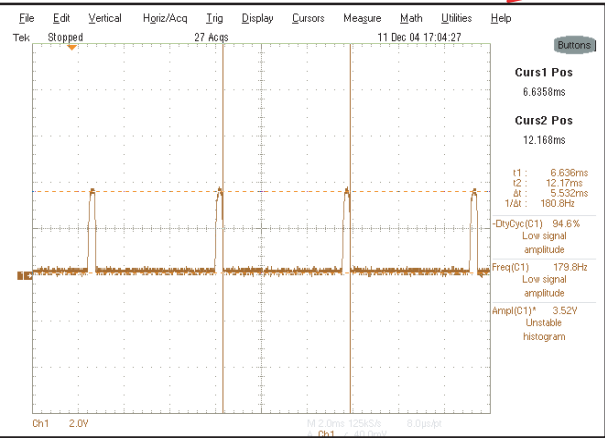

5V 180Hz

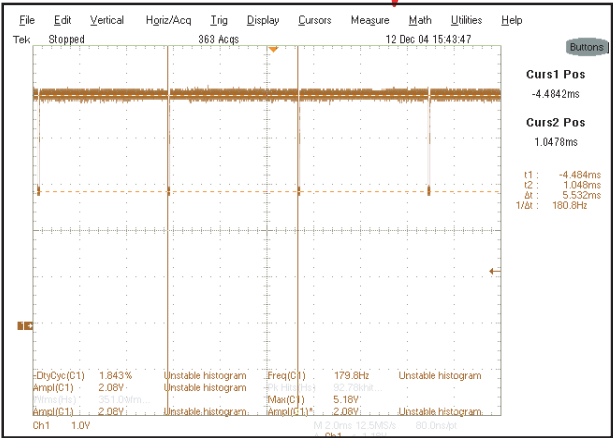

6-3-2 When the lamp and the ballast are normal but the lamp does not turn on or turns off right after quickly lighting up.

1. Check the color wheel

Check if the color wheel is running. + Check the DMD board and the ballast for the signals.

Check the second CN503 pin for input signals. When 3.5V, 180Hz is output, the color wheel is operating normally.

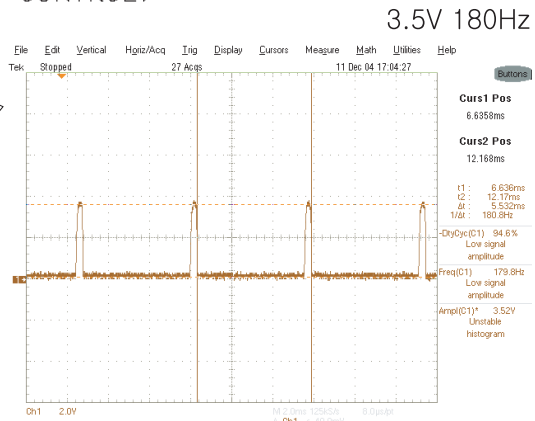
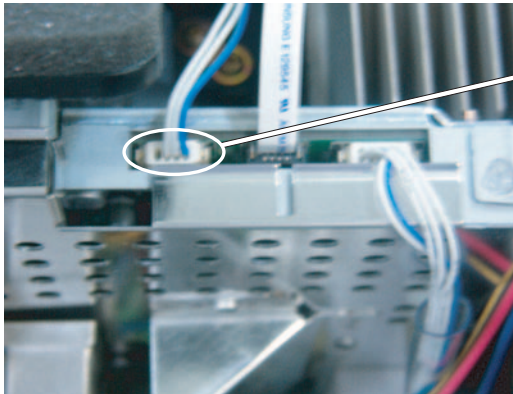
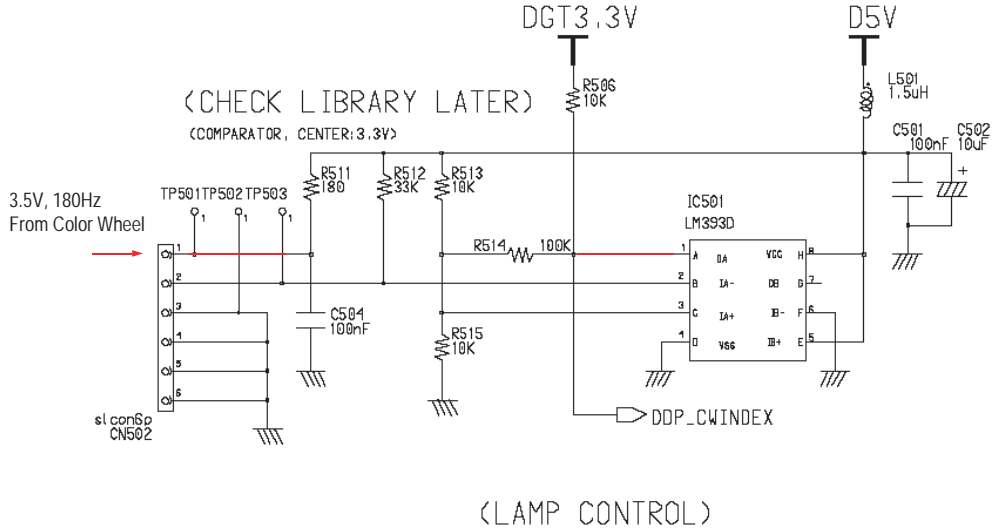

※ DMD Board Check Diagram

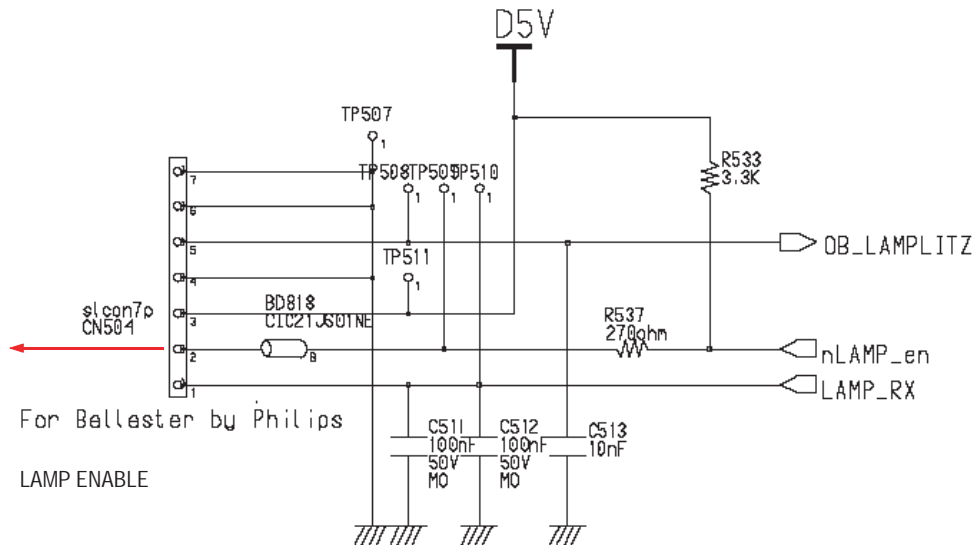

6-3-3 DDP1011 Electronics Debugging Flow Diagram

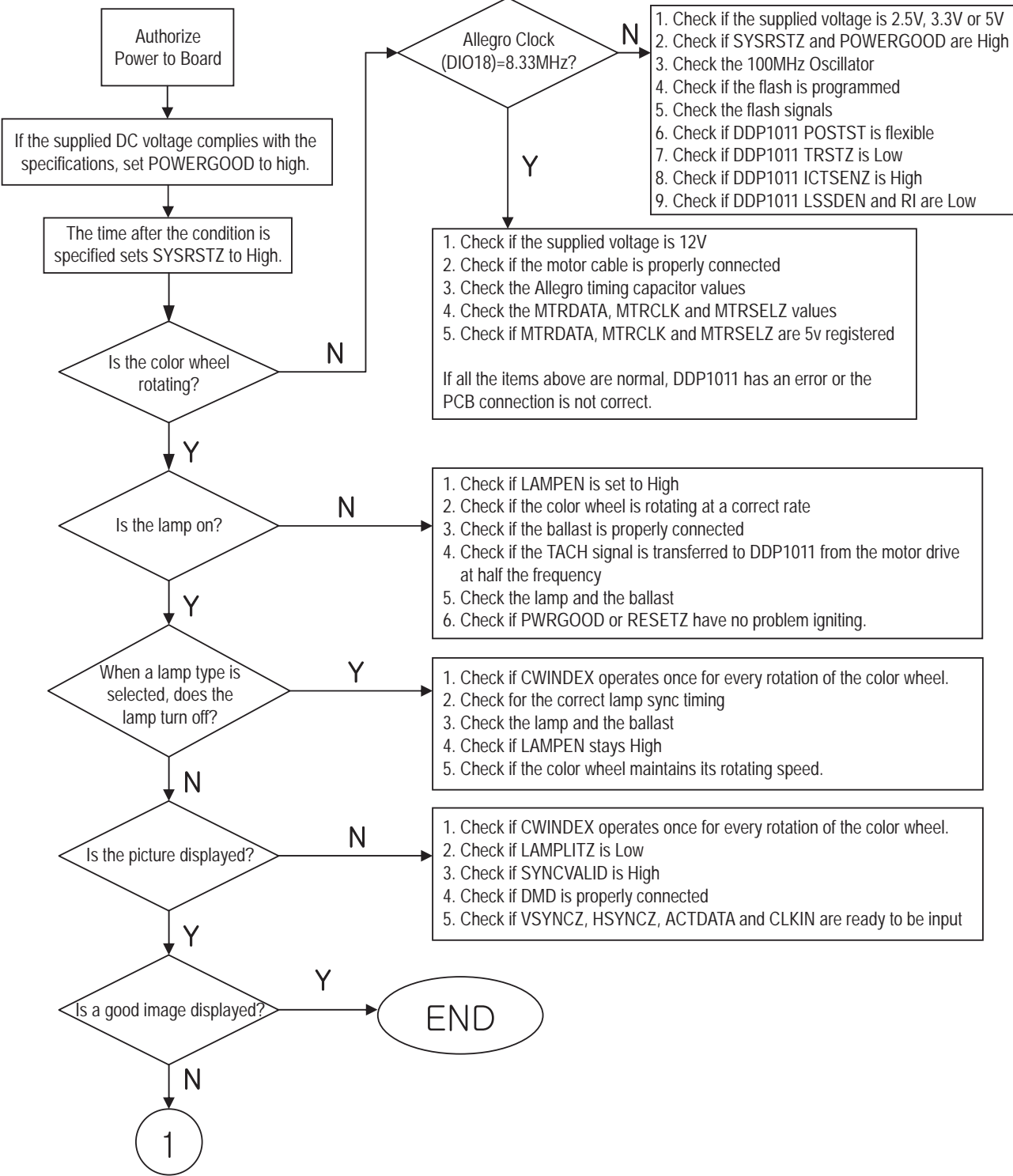

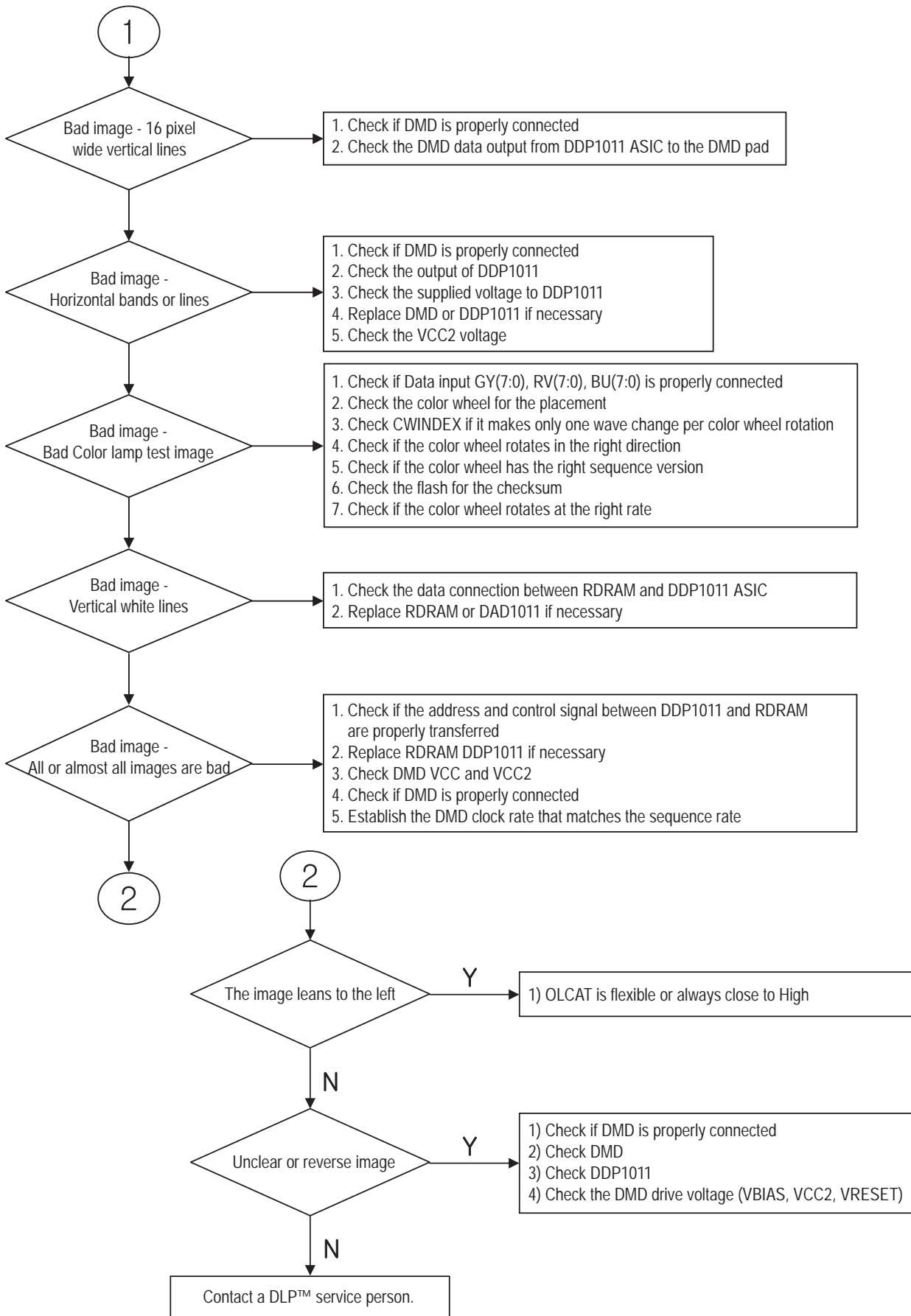

7. Block Diagram

7-1 Overall Block Diagram

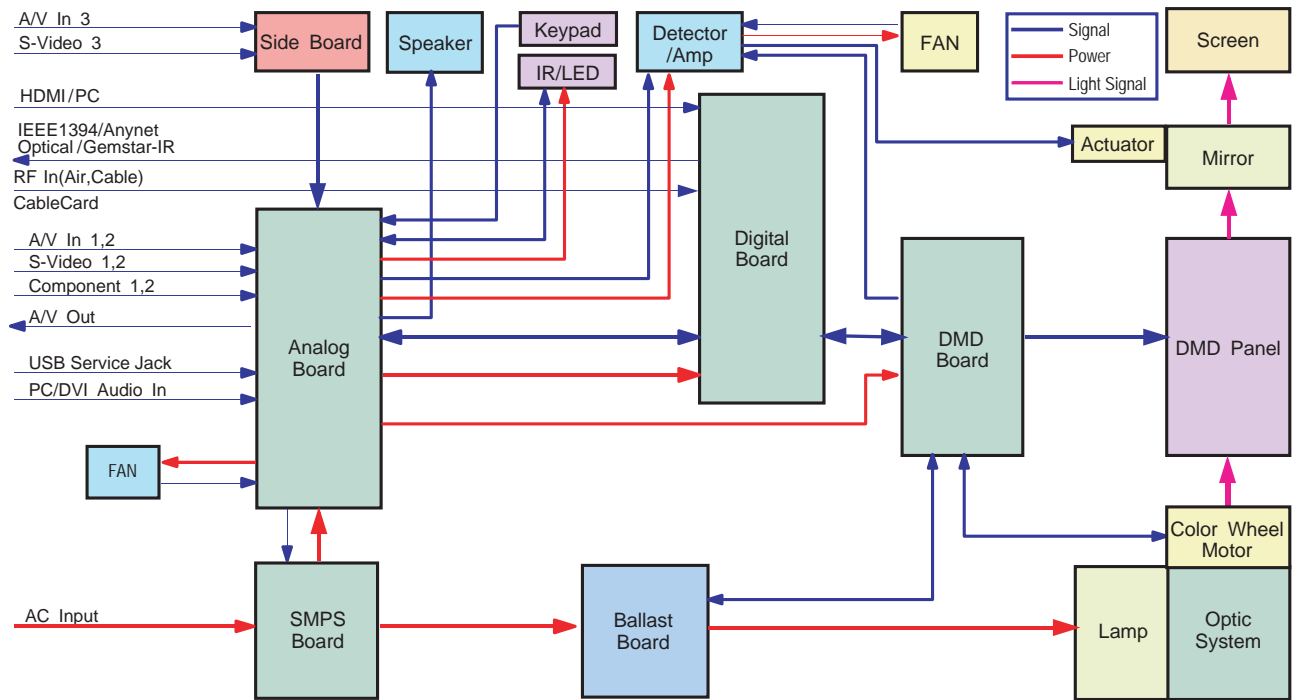

7-2 Partial Block Diagram

7-2-1 Power Board Block Diagram

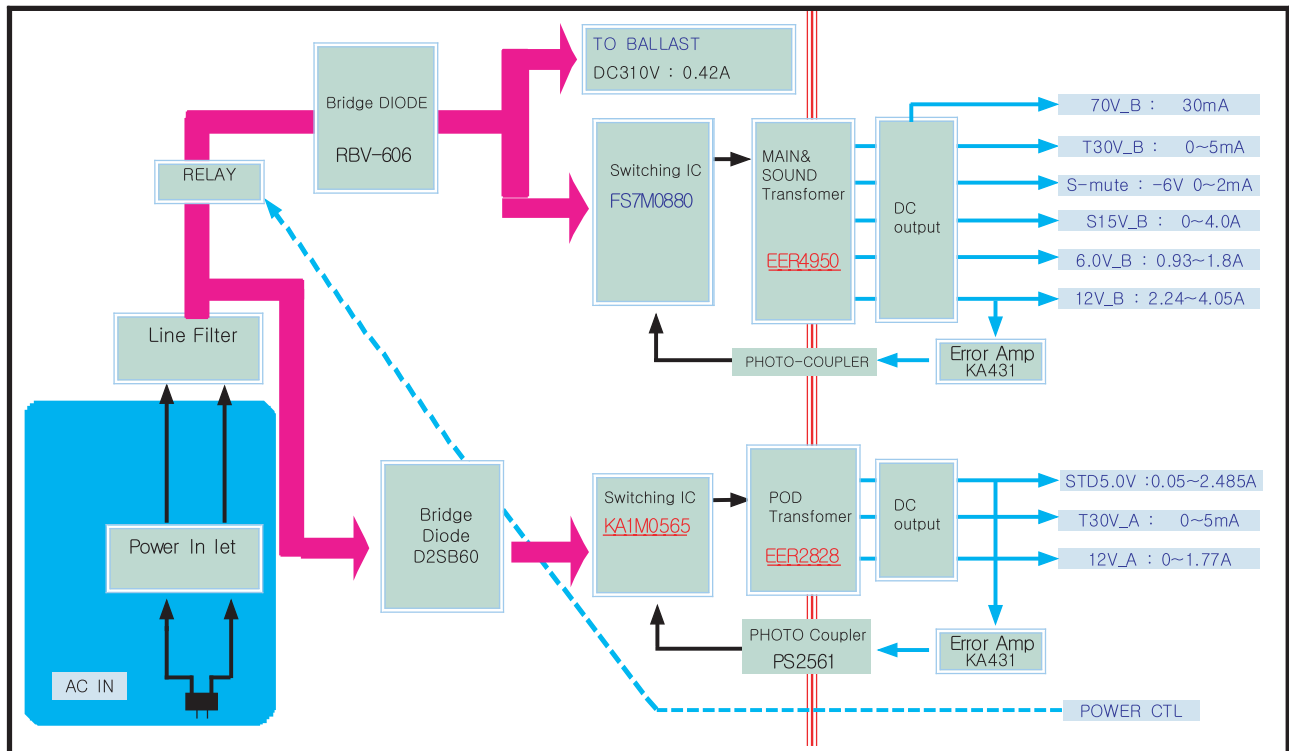

7-2-2 Digital Board Block Diagram

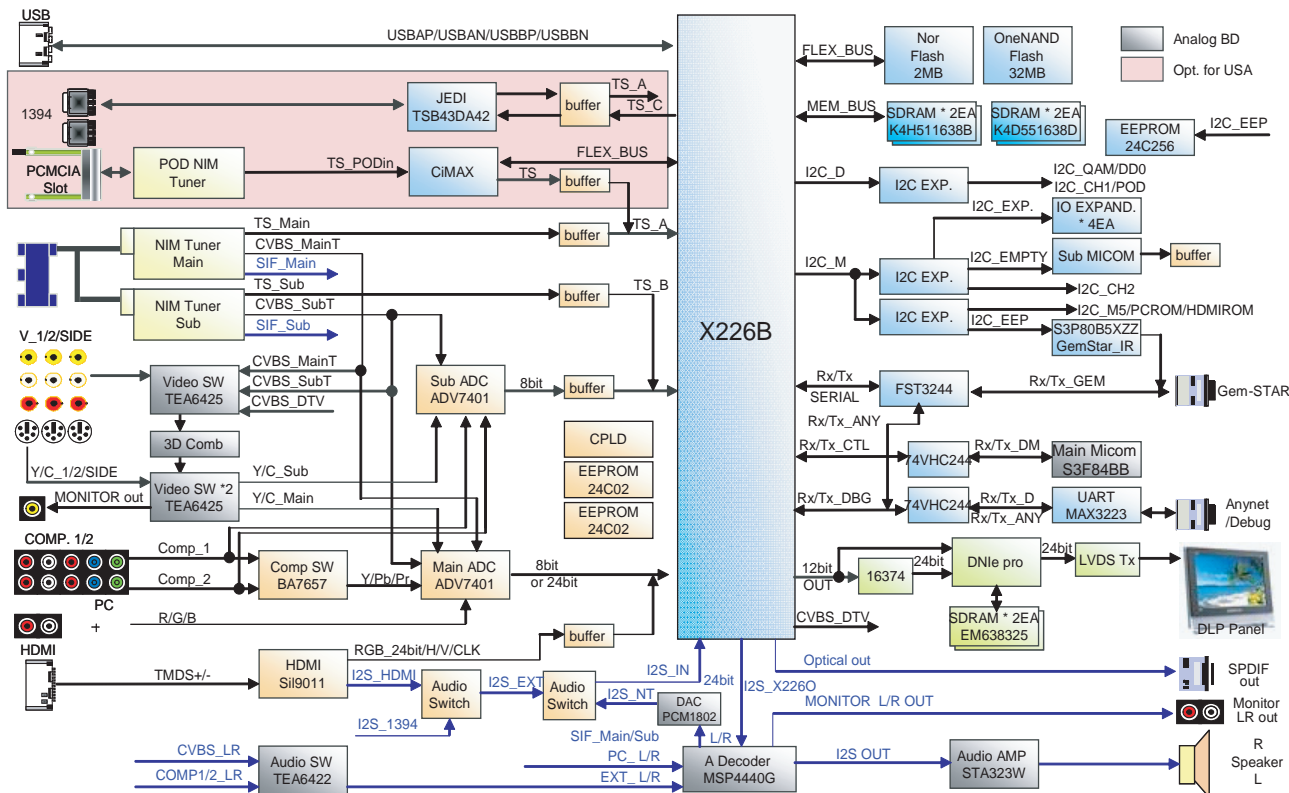

7-2-3 Analog Board Block Diagram

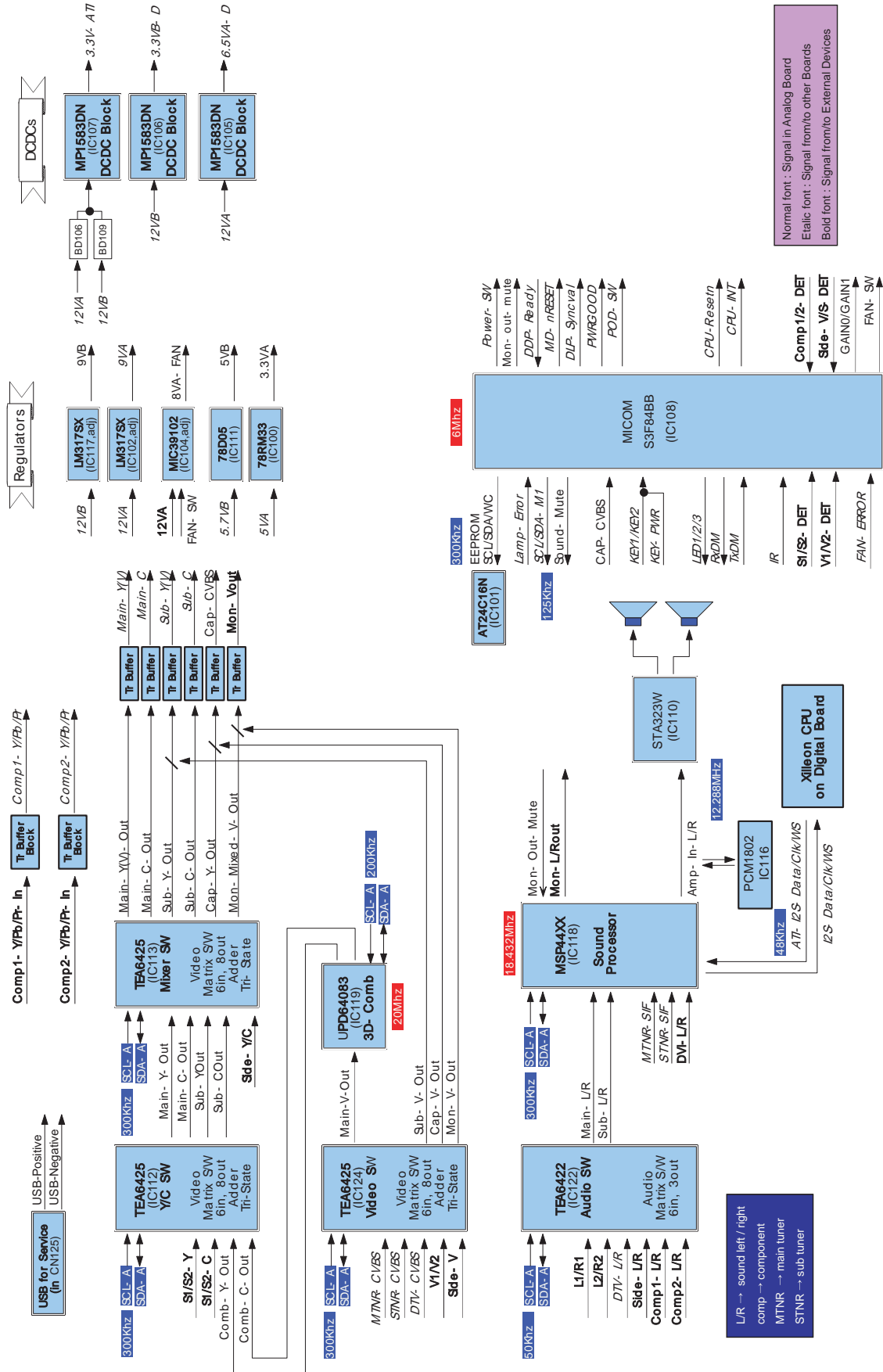

7-2-4 DMD Board Block Diagram

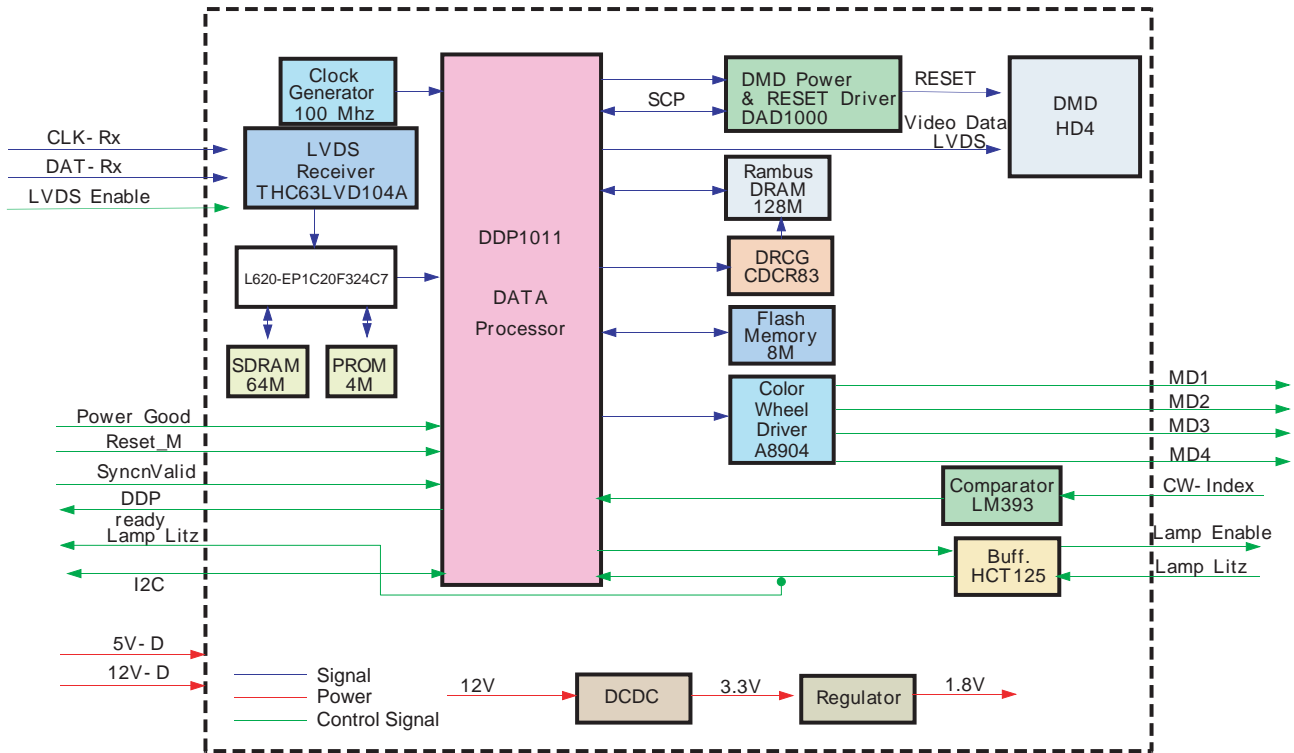

8. Wiring Diagram

8-1 Overall Wiring

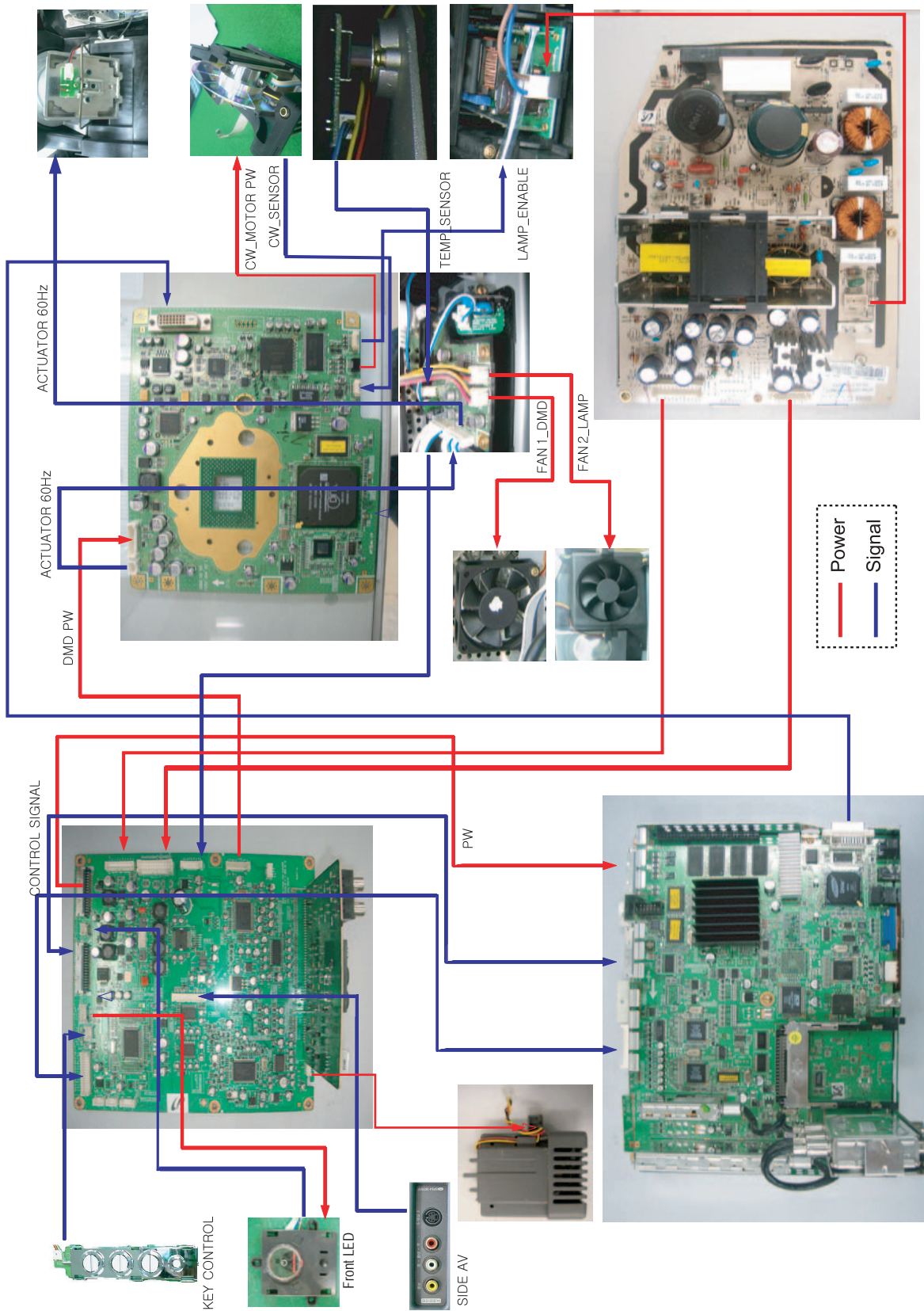

8-2 Connection between Analog and Digital Board

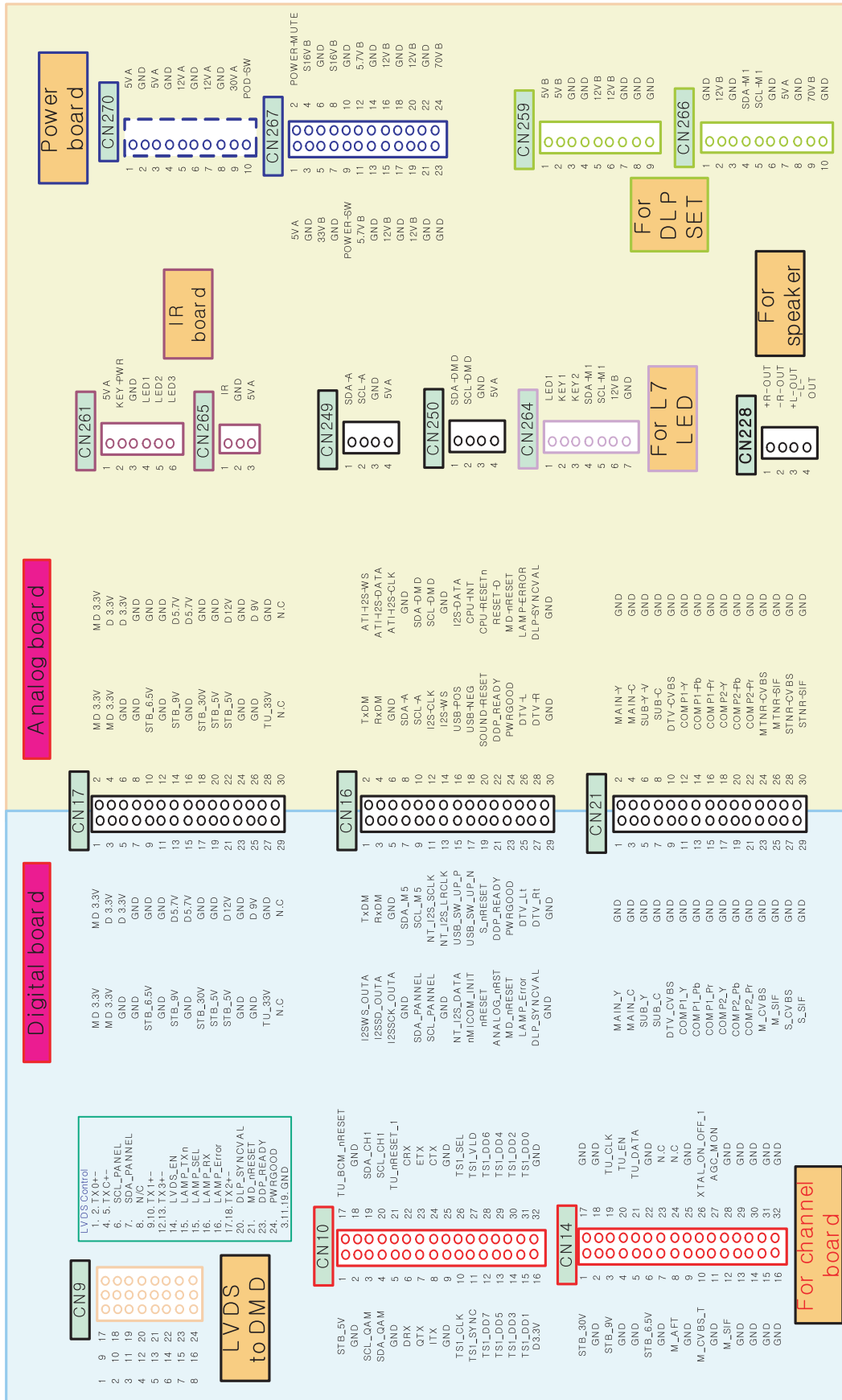

9. PCB Diagram

9-1 Power Board

9-1-1 Assy Power Board

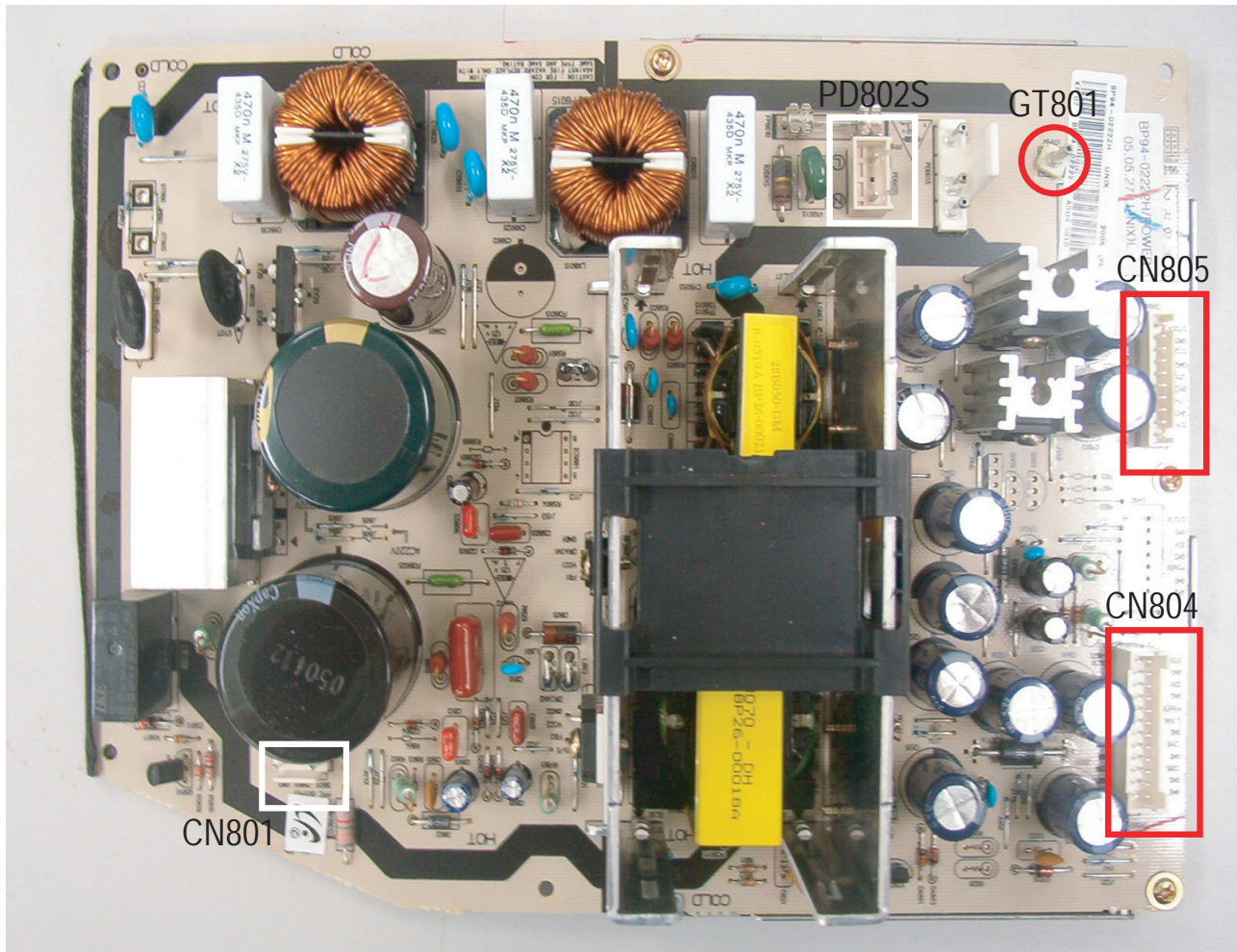

■ DC Power Supply

(Supplies DC power to the analog PCB. The analog board is responsible for the power supply to the digital/DMD board.)

9-1-2 Names & Roles of Key Parts

- * CN801 : Supplies power (DC330V \pm 10%) to the ballast.
- * GT801 : Anti-lightning wire connected to the digital board. The anti-lightning wire should be installed for safety purposes.
- * PD802S : Inlet type of terminal that is connected to the AC power cable.

9-1-3 Power Board Connector Pin

CN805

Connecting Power to Analog Board

Pin No.	Pin Name
1	STD 5V
2	GND
3	STD 5V
4	GND
5	12VA
6	GND
7	12VA
8	GND
9	33VA
10	POD-SW

CN804

Connecting Power to Analog Board

Pin Name	PIN No.		Pin Name
STD 5V	1	2	S-MUTE
GND	3	4	S14.5V
33V	5	6	GND
GND	7	8	S14.5V
POWER-SW	9	10	GND
5.5VB	11	12	5.5VB
GND	13	14	GND
12VB	15	16	12VB
GND	17	18	GND
12VB	19	20	12VB
GND	21	22	GND
GND	23	24	80VB

9-2 Digital Board

9-2-1 Assy Digital Board

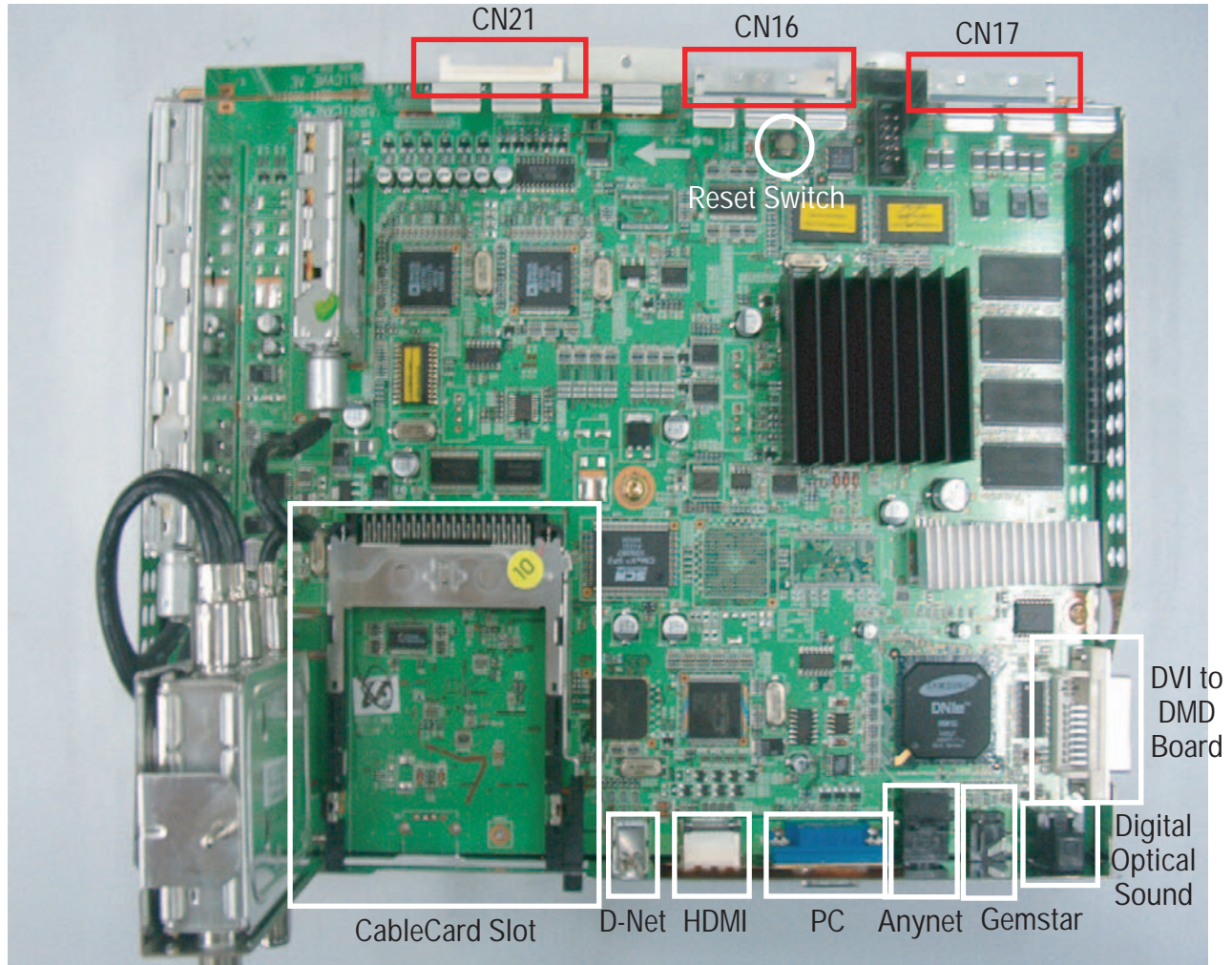

- Microprocessor (Generates turn-on signal to power board)
- All Digital Video Processing
- OSD / Menu
- Reset Switch

9-2-2 Names & Roles of Key Parts

* CableCard :

CableCARD is a nationwide standard system that allows your local cable TV provider to supply you with an access card customized to your account. This card allows the TV to receive, decode and unscramble the premium digital channels included in your cable TV subscription without the use of a cable box.

* High Definition Multimedia Interface :

The HDMI™ (High Definition Multimedia Interface) supports uncompressed standard and high definition digital video formats and existing digital multi-channel audio formats.

* G-Link :

This jack is used by the TV Guide On screen system of the TV to control external analog devices such as VCRs, DVDs, cable boxes, satellite receivers and audio receivers.

* D-Net(IEEE1394) :

These jacks allow the TV to connect to external IEEE 1394 digital products by means of a single cable.

9-2-3 Digital Board Connector Pin

CN16

Connecting the control signal between Digital & Analog Board

Pin Name	PIN No.		Pin Name
I2SWS_OUTA	1	2	TxDM
I2SSD_OUTA	3	4	RxDM
I2SCLK_OUTA	5	6	GND
GND	7	8	SDA_M5
SDA_PANNEL	9	10	SCL_M5
SCL_PANNEL	11	12	NT_I2S_SCLK
GND	13	14	NT_I2S_LRCLK
NT_I2S_DATA	15	16	USB_SW_UP_P
nMICOM_INIT	17	18	USB_SW_UP_N
nRESET	19	20	S_nRESET
ANALOG-nRST	21	22	DDP_READY
MD-nRESET	23	24	PWRGOOD
LAMP-ERROR	25	26	DTV_Lt
DLP-SYNCVAL	27	28	DTV_Rt
GND	29	30	GND

CN17

Connecting Power to the Digital Board

Pin Name	PIN No.		Pin Name
MD3.3V	1	2	MD3.3V
MD3.3V	3	4	D3.3V
GND	5	6	D3.3V
GND	7	8	GND
STB_6.5V	9	10	GND
GND	11	12	GND
STB_9V	13	14	D5.7V
GND	15	16	D5.7V
STB_30V	17	18	GND
STB_5V	19	20	GND
5VA	21	22	D12V
GND	23	24	GND
GND	25	26	D9V
33V	27	28	GND

CN21

Connecting the Audio/Video signal from the rear input terminal

Pin Name	PIN No.		Pin Name
MAIN_Y	1	2	GND
MAIN_C	3	4	GND
SUB_Y	5	6	GND
SUB_C	7	8	GND
DTV_CVBS	9	10	GND
COMP1_Y	11	12	GND
COMP1_Pb	13	14	GND
COMP1_Pr	15	16	GND
COMP2_Y	17	18	GND
COMP2_Pb	19	20	GND
COMP2_Pr	21	22	GND
M-CVBS	23	24	GND
M-SIF	25	26	GND
S-CVBS	27	28	GND
S-SIF	29	30	GND

9-3 Analog Board

9-3-1 Assy Analog Board

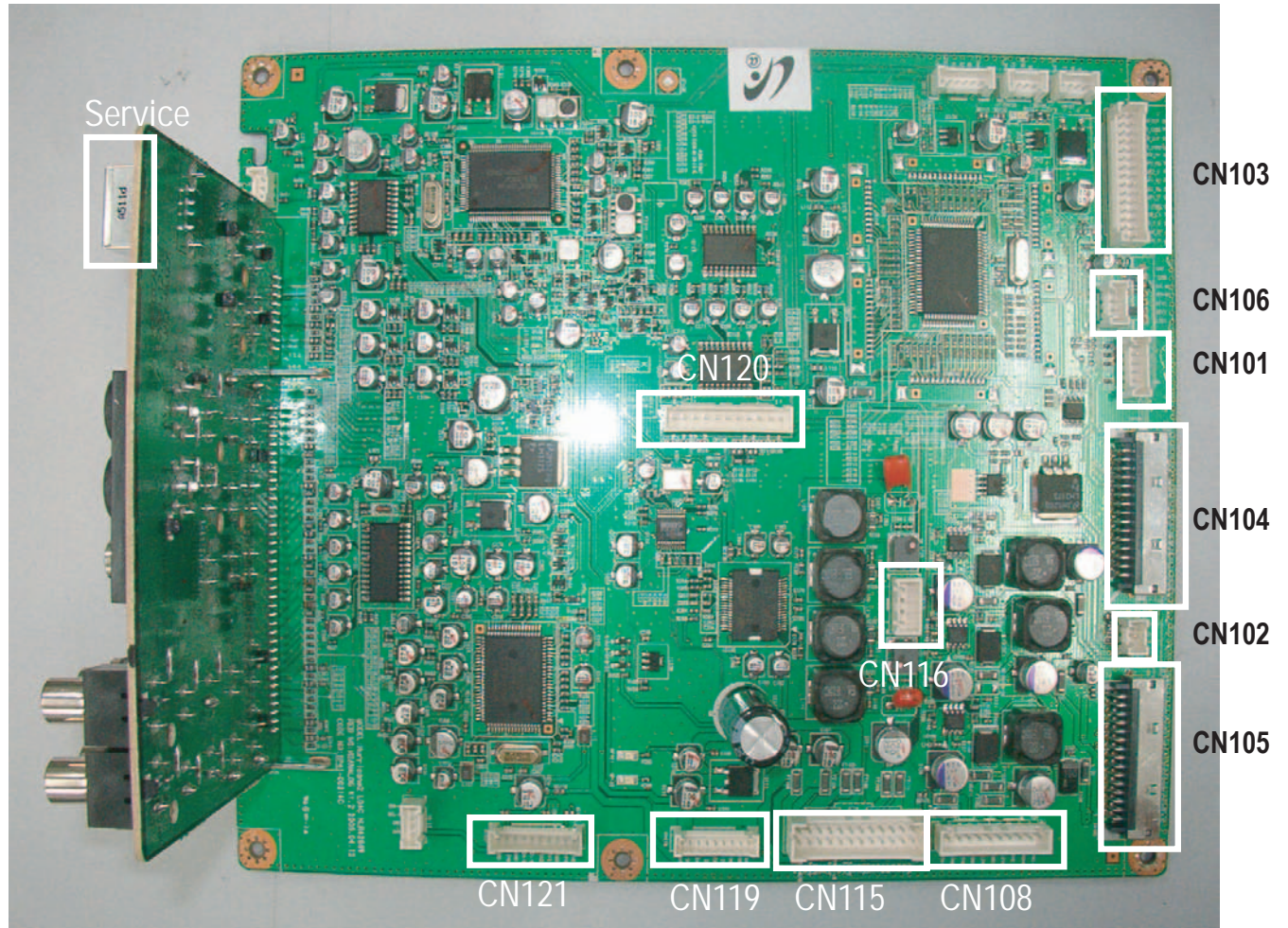

- Distributes supply voltage from the Power Board to Digital Board and DMD Board.
- Transfers Turn-on Command to Digital and Power Board.
- Encompasses the majority of the Audio Circuit
- Analog Video Switching / Processing
- Analog Audio Switching / Processing

9-3-2 Names & Roles of Key Parts

- * CN121 : Connected to the actuator board
- * CN119 : Connected to the DMD board
- * CN115 : Connected to the power board - receives the second power source generated on the power board.
- * CN105 : Sends the power source from the analog to the digital board.
- * CN104 : This is a control signal terminal that connects between the analog and digital boards.
- * CN103 : This is an AV signal terminal that connects between the analog and digital boards.

9-3-3 Analog Board Connector Pin

CN122

For Debugging

Pin No.	Pin Name
1	SDA-DMD
2	SCL-DMD
3	GND
4	5VA

CN123

For Debugging

Pin No.	Pin Name
1	SDA-A
2	SCL-A
3	GND
4	5VA

CN119

Connecting Power to the DMD

Pin No.	Pin Name
1	5VB
2	5VB
3	GND
4	GND
5	12VB
6	12VB
7	GND
8	GND
9	GND

CN121

Connecting Power and the Control Signal to the Actuator Protection Board

Pin No.	Pin Name
1	GND
2	12VB
3	GND
4	SDA-M1
5	SCL-M1
6	GND
7	5VA
8	GND
9	70VB
10	GND

CN105

Connecting Power to the Digital Board

Pin Name	PIN No.		Pin Name
3.3V-ATI	1	2	3.3V-ATI
3.3VB-D	3	4	3.3V-ATI
3.3VB-D	5	6	GND
GND	7	8	GND
GND	9	10	6.5VA-D
GND	11	12	GND
5.7VB	13	14	9VA
5.7VB	15	16	GND
GND	17	18	30VA
GND	19	20	5VA
12VB	21	22	5VA
GND	23	24	GND
9VB	25	26	GND
GND	27	28	33VB
GND	29	30	GND

CN102

Connecting the IR signal

Pin No.	Pin Name
1	IR
2	GND
3	5VA

CN101

Connecting front LED indicators

Pin No.	Pin Name
1	5VA
2	KEY-PWR
3	GND
4	LED1
5	LED2
6	LED3

CN116

Connecting and transmitting Audio signal to Speaker

Pin No.	Pin Name
1	-L-OUT
2	+L-OUT
3	-R-OUT
4	+R-OUT

CN124

Connecting the Power and Control Signal to the POD Fan

Pin No.	Pin Name
1	FAN-ERROR
2	GND
3	8VA-FNA

CN106

Connecting Side Buttons

Pin No.	Pin Name
1	GND
2	KEY1
3	KEY2
4	GND

CN120

Transmitting Video Signal from Side Terminal

Pin No.	Pin Name
1	SIDE-Y
2	SIDE-C
3	GND
4	SIDE-V
5	GND
6	SIDE-L
7	GND
8	SIDE-R
9	GND
10	SIDE-SDET
11	SIDE-VDET

CN103

Connecting the Audio/Video signal from the rear input terminal

Pin Name	PIN No.		Pin Name
MAIN_Y	1	2	GND
MAIN_C	3	4	GND
SUB_Y_V	5	6	GND
SUB_C	7	8	GND
DTV_CVBS	9	10	GND
COMP1_Y	11	12	GND
COMP1_Pb	13	14	GND
COMP1_Pr	15	16	GND
COMP2_Y	17	18	GND
COMP2_Pb	19	20	GND
COMP2_Pr	21	22	GND
MTNR_CVBS	23	24	GND
MTNR_SIF	25	26	GND
STNR_CVBS	27	28	GND
STNR_SIF	29	30	GND

CN104

Connecting the control signal between Digital and Analog

Pin Name	PIN No.		Pin Name
TxDM	1	2	ATI-I2S-WS
RxDM	3	4	ATI-I2S-DATA
GND	5	6	STI-I2S-CLK
SDA_A	7	8	GND
SCL_A	9	10	SDA_DMD
I2SCLK	11	12	SCL_DMD
I2S_WS	13	14	GND
USB_POS	15	16	I2S_DATA
USB_NEG	17	18	CPU_INIT
SOUND_RESET	19	20	CPU_RESET
DDP_READY	21	22	RESET_D
PWRGOOD	23	24	MD_nRESET
DTV_L	25	26	LAMP_ERROR
DTV_R	27	28	DLP_SYNCVAL
GND	29	30	GND

CN105

Connecting Power

Pin Name	PIN No.		Pin Name
5VA	1	2	POWER-MUTE
GND	3	4	S16VB
33VB	5	6	GND
GND	7	8	S16VB
POWER-SW	9	10	GND
5.7VB	11	12	5.7VB
GND	13	14	GND
12VB	15	16	12VB
GND	17	18	GND
12VB	19	20	12VB
GND	21	22	GND
GND	23	24	70VB

CN108

Connecting Power

Pin No.	Pin Name
1	5VA
2	GND
3	5VA
4	GND
5	12VA
6	GND
7	12VA
8	GND
9	30VA
10	POD-SW

9-4 DMD Board

9-4-1 Assy DMD Board

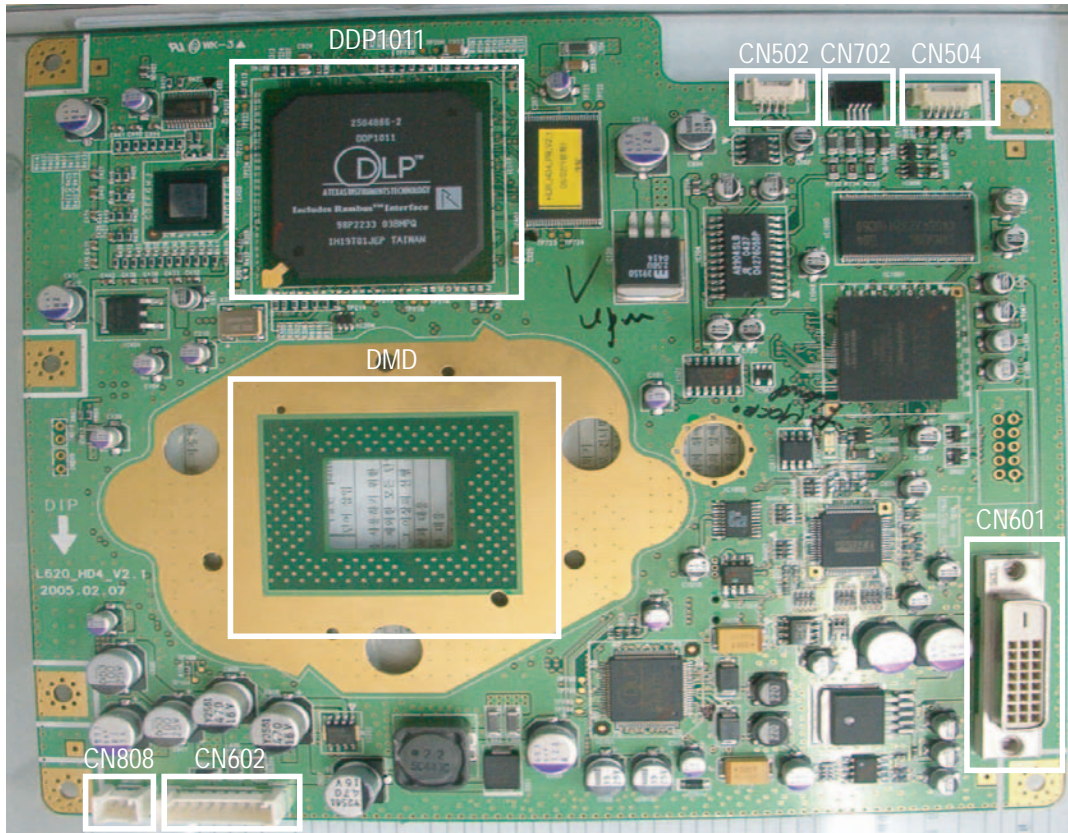

- Controls the lamp (ON/OFF)
- Drives the color wheel motor
- Drives the panel
- Controls the sensors

9-4-2 Names & Roles of Key Parts

- * CN602 : This receives the power source from the analog board and communicates with the I2C.
- * CN808 : This sends a 60Hz signal to the actuator board. The actuator board sends the signal to the actuator module.
- * CN702 : This supplies the power to drive the color wheel.
- * CN502 : This receives the color wheel rotating signals.
- * CN504 : This sends signals to the ballast.
- * CN601 : The DVD cable terminal. This receives the image data from the digital board.
- * DMD PANEL : This is protected with a heat sink and fixtures.
- * DDP1011 : This processes the DMD drive and the signals.

10. Schematic Diagram

10-1 Analog Board

10-1-1 PowerSignal

This Document can not be used without Samsung's authorization.

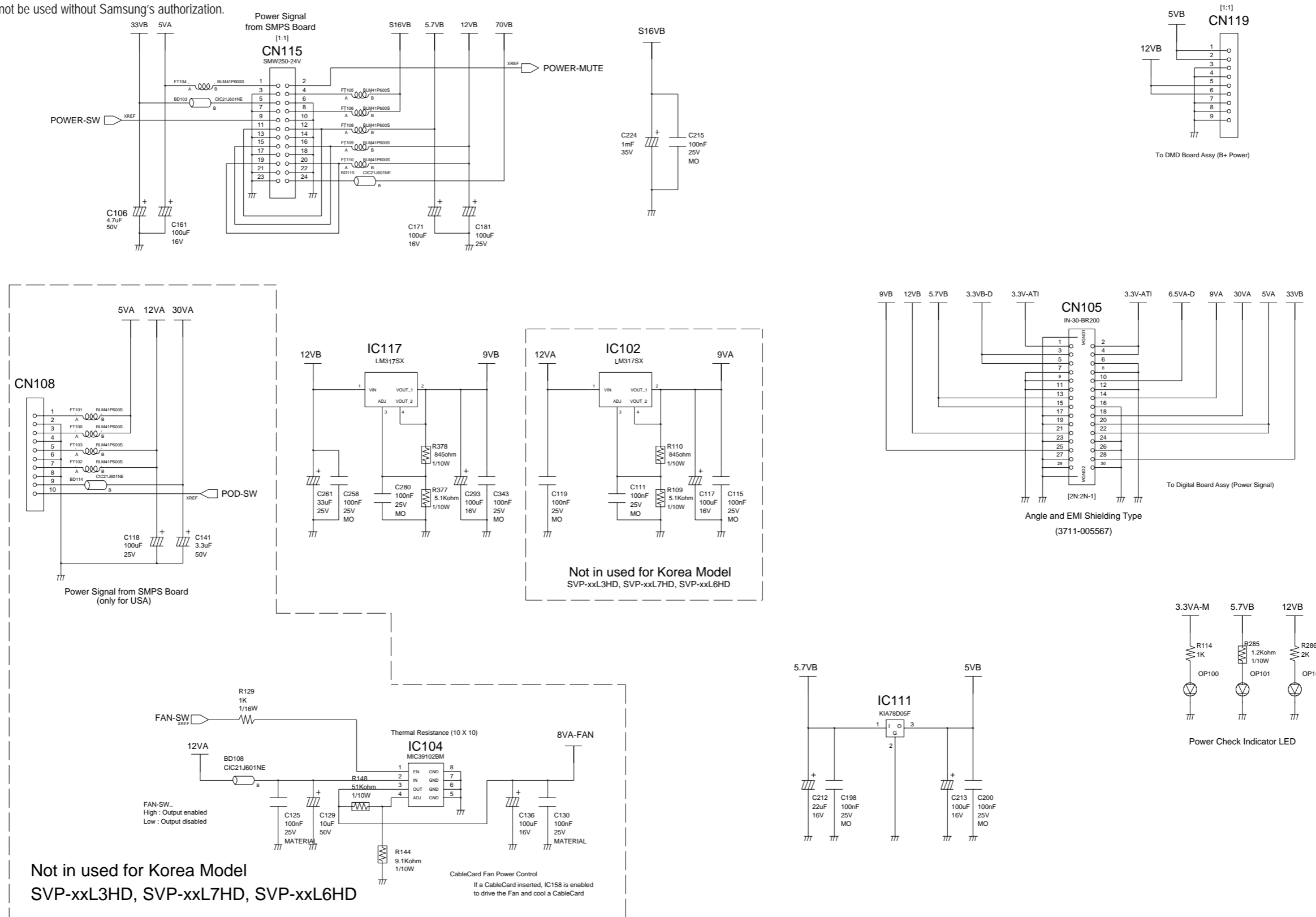

10-1-2 DCDC

This Document can not be used without Samsung's authorization.

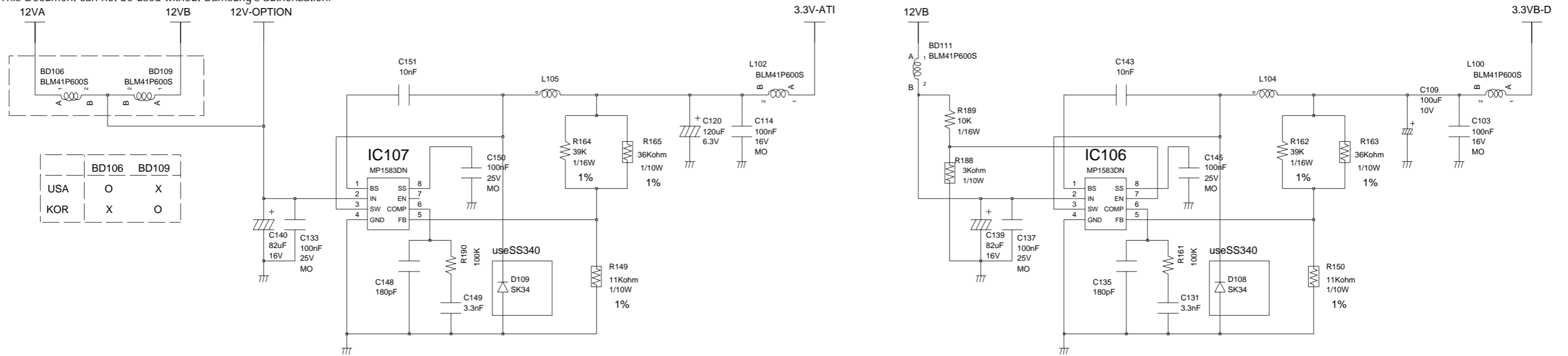

	BD106	BD109
USA	O	X
KOR	X	O

DCDC Converter for Power of ATI-CPU

USA : STD power
KOR : B+ power

DCDC Converter for Power of ATI-CPU

USA/KOR Common B+ power

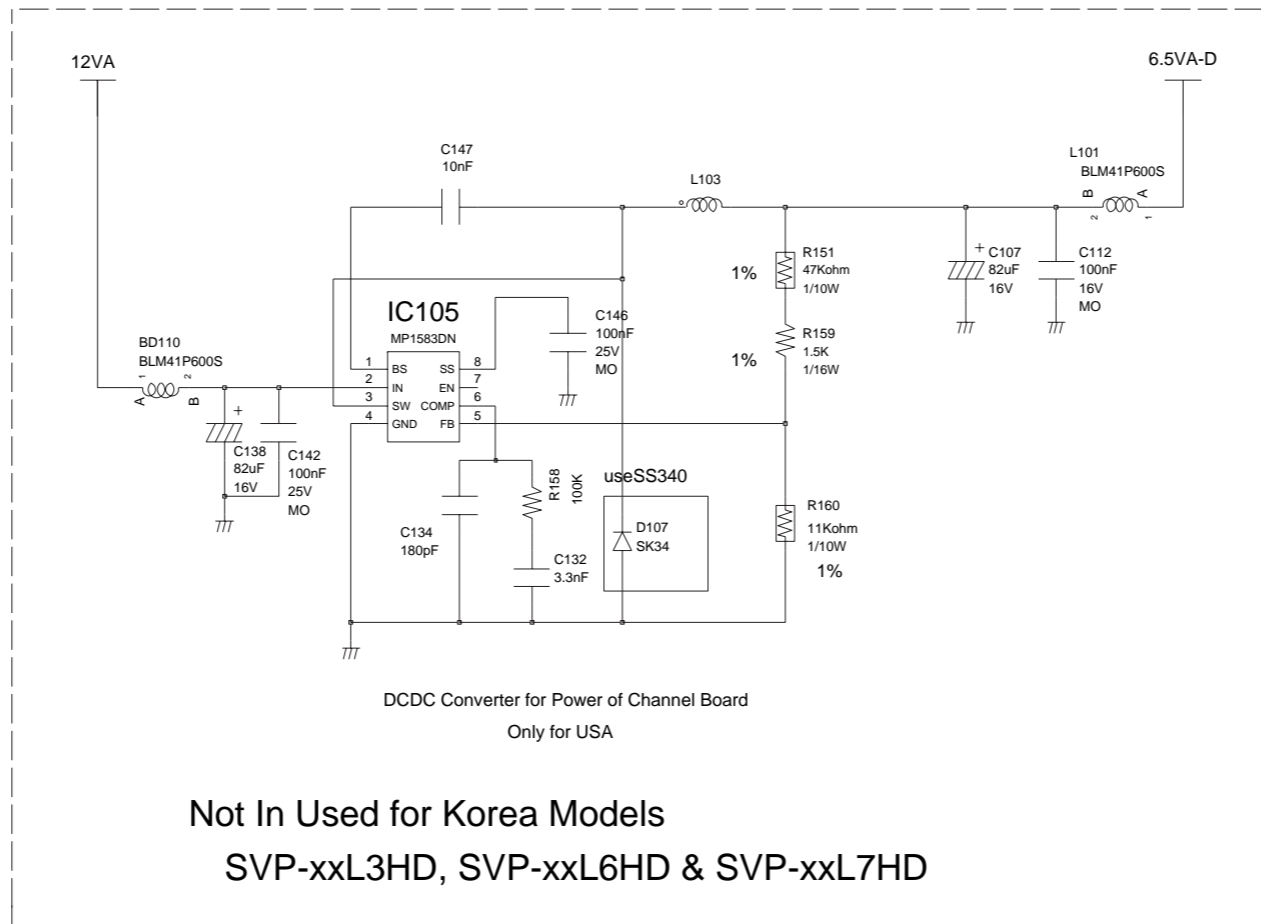

DCDC Converter for Power of Channel Board

Only for USA

Not In Used for Korea Models

SVP-xxL3HD, SVP-xxL6HD & SVP-xxL7HD

10-1-3 AV_Input

This Document can not be used without Samsung's authorization.

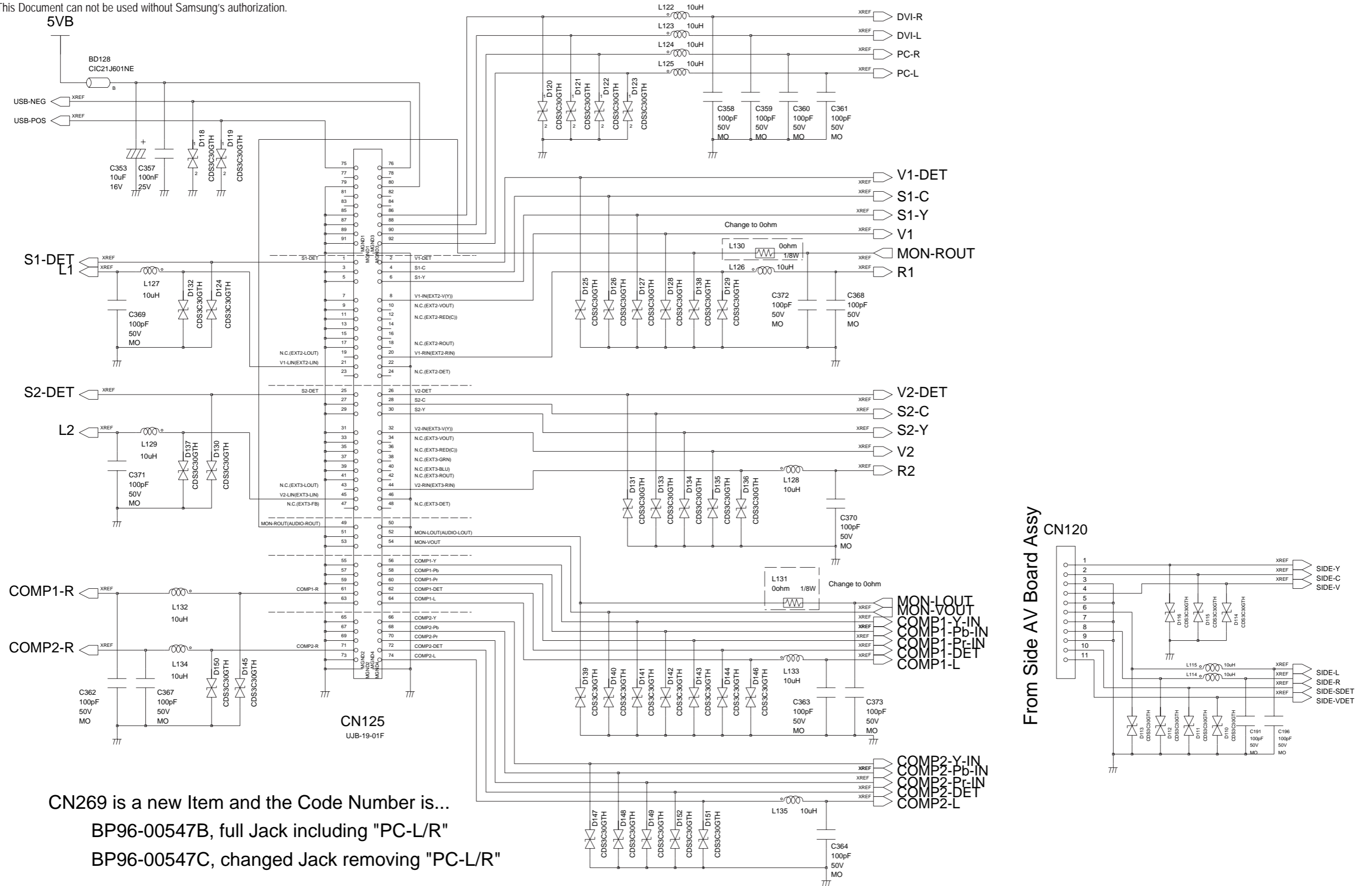

CN269 is a new Item and the Code Number is...
 BP96-00547B, full Jack including "PC-L/R"
 BP96-00547C, changed Jack removing "PC-L/R"

10-1-4 AV Switching

This Document can not be used without Samsung's authorization.

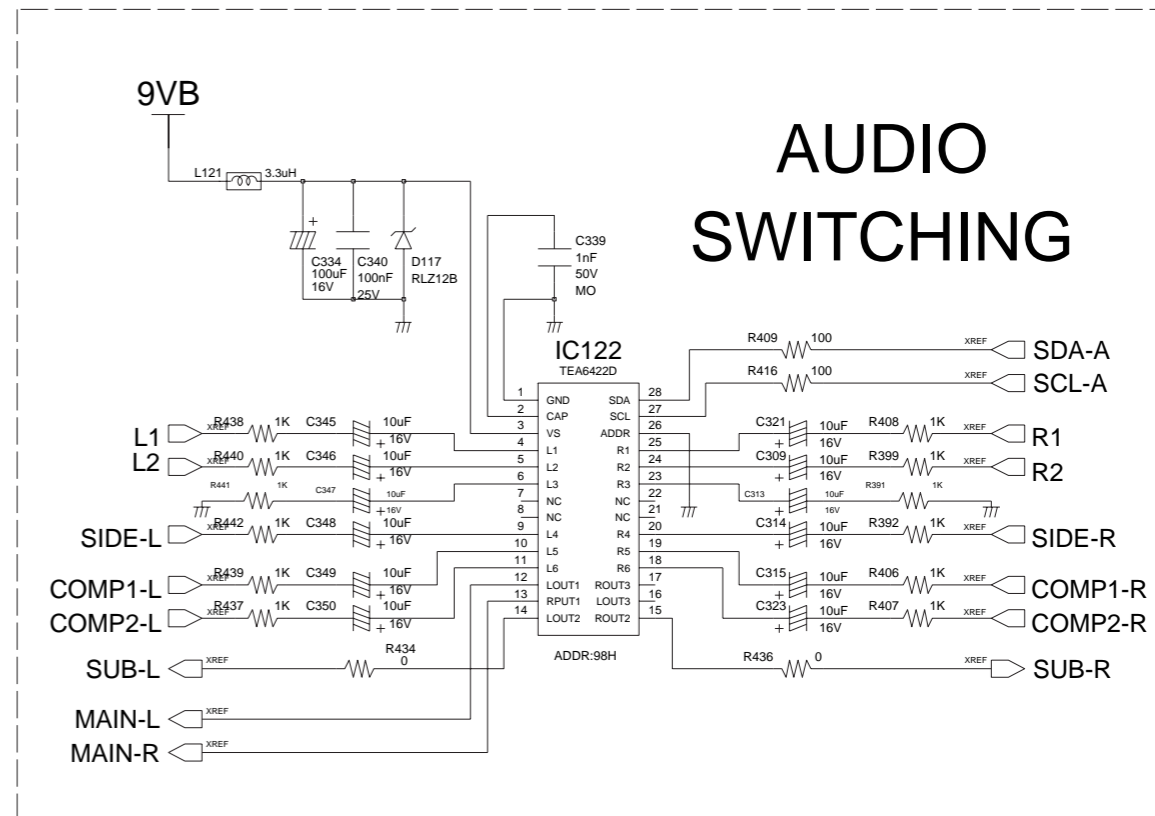
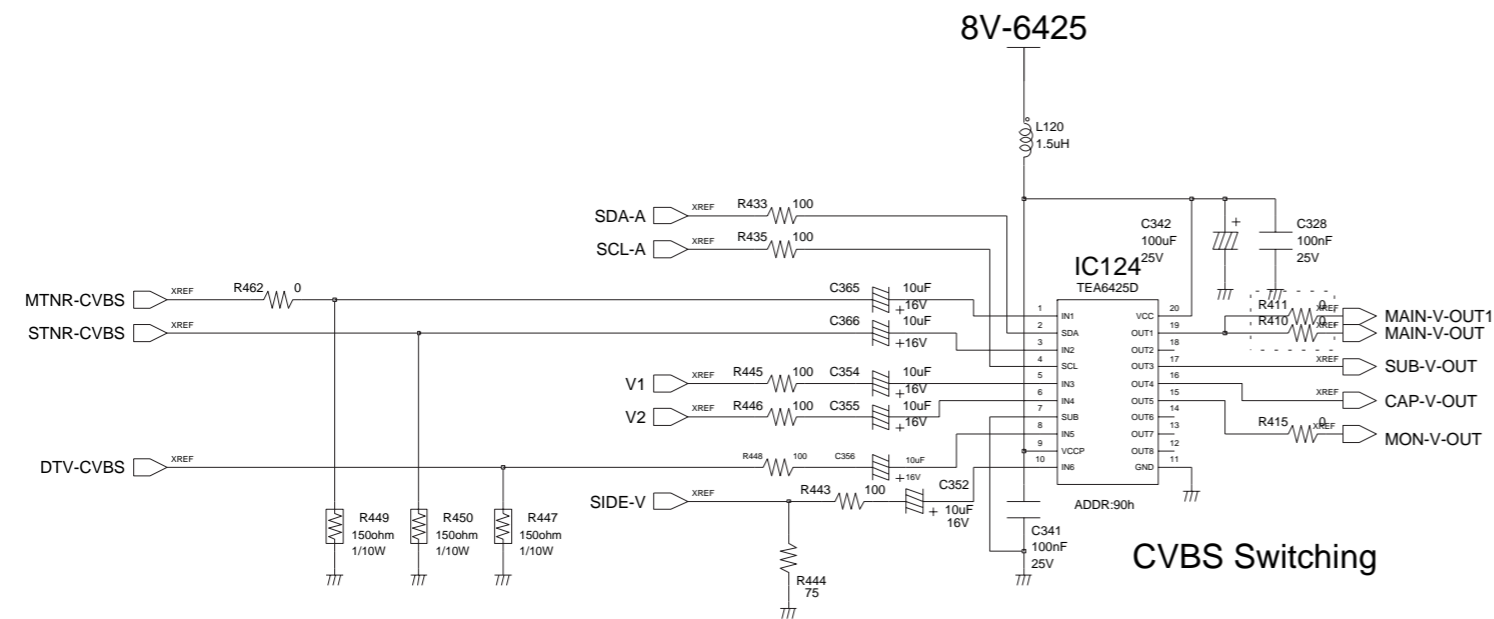
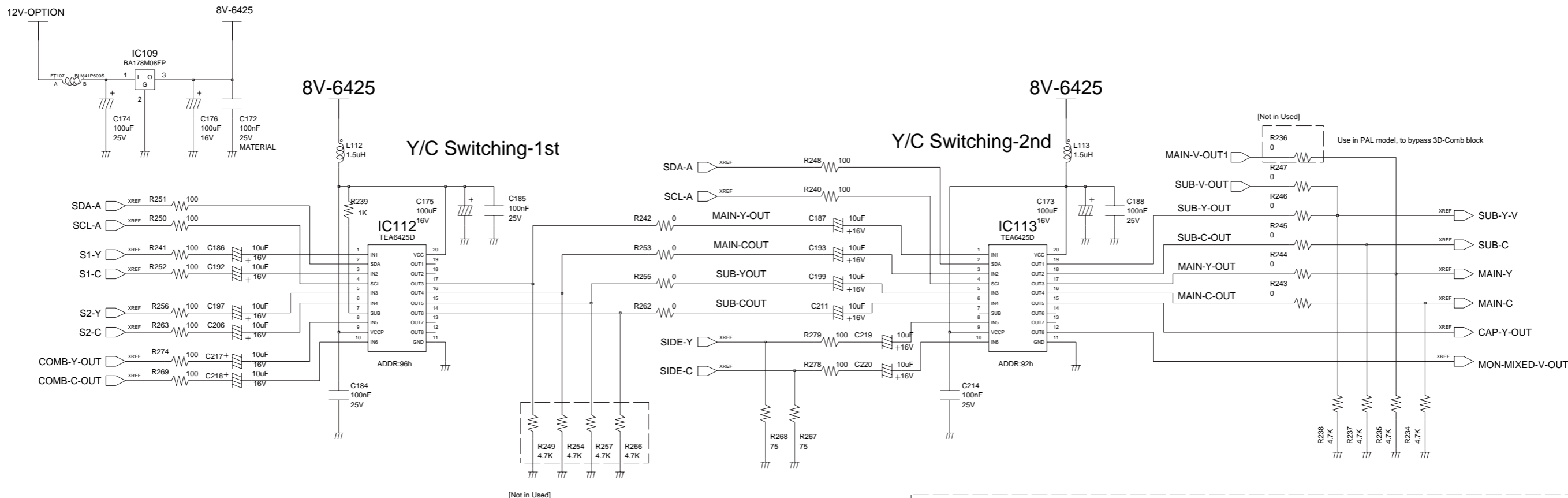

10-1-5 AV_Comp_Buffer

This Document can not be used without Samsung's authorization.

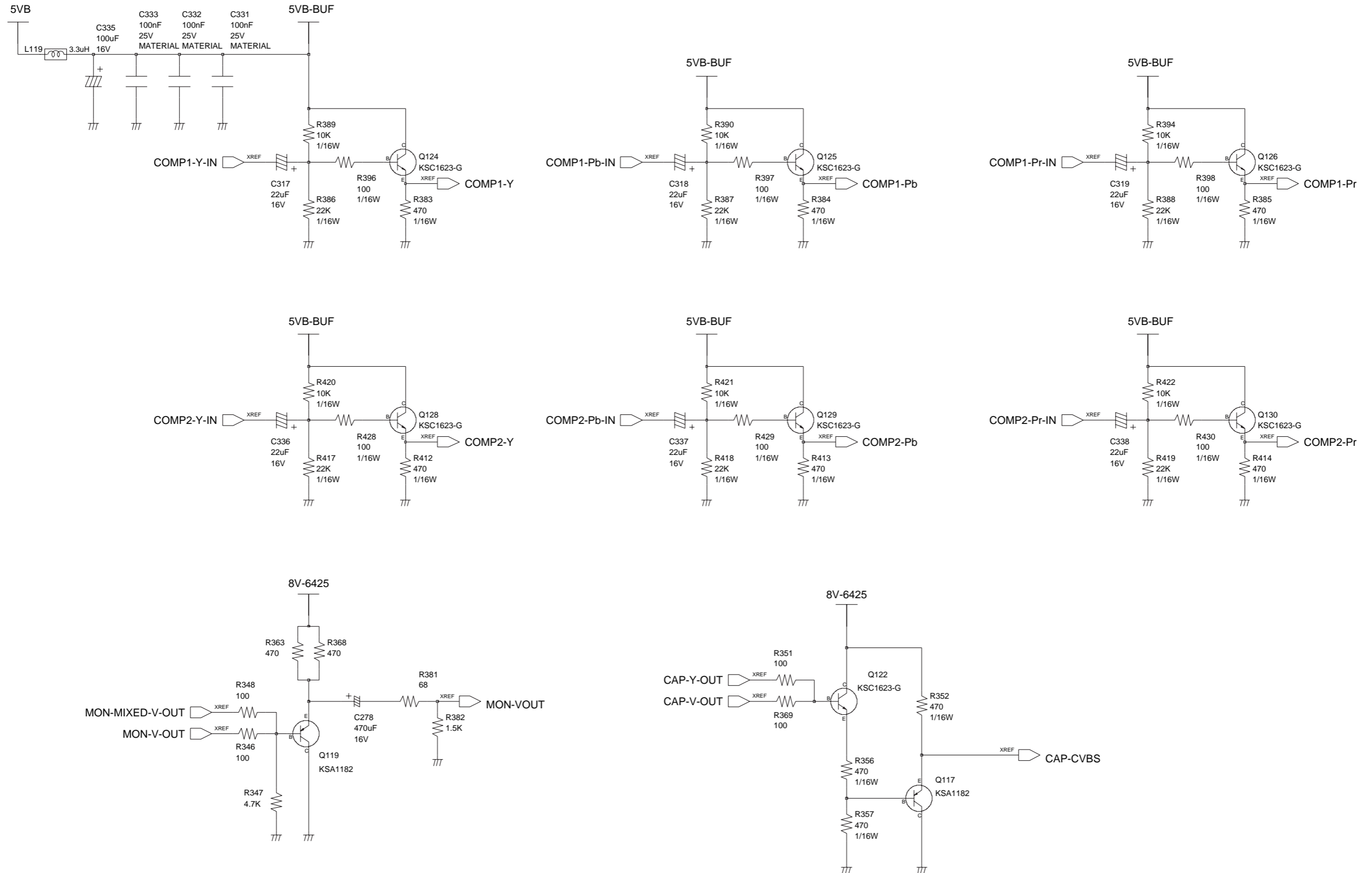

10-1-6 3D-Comb

This Document can not be used without Samsung's authorization.

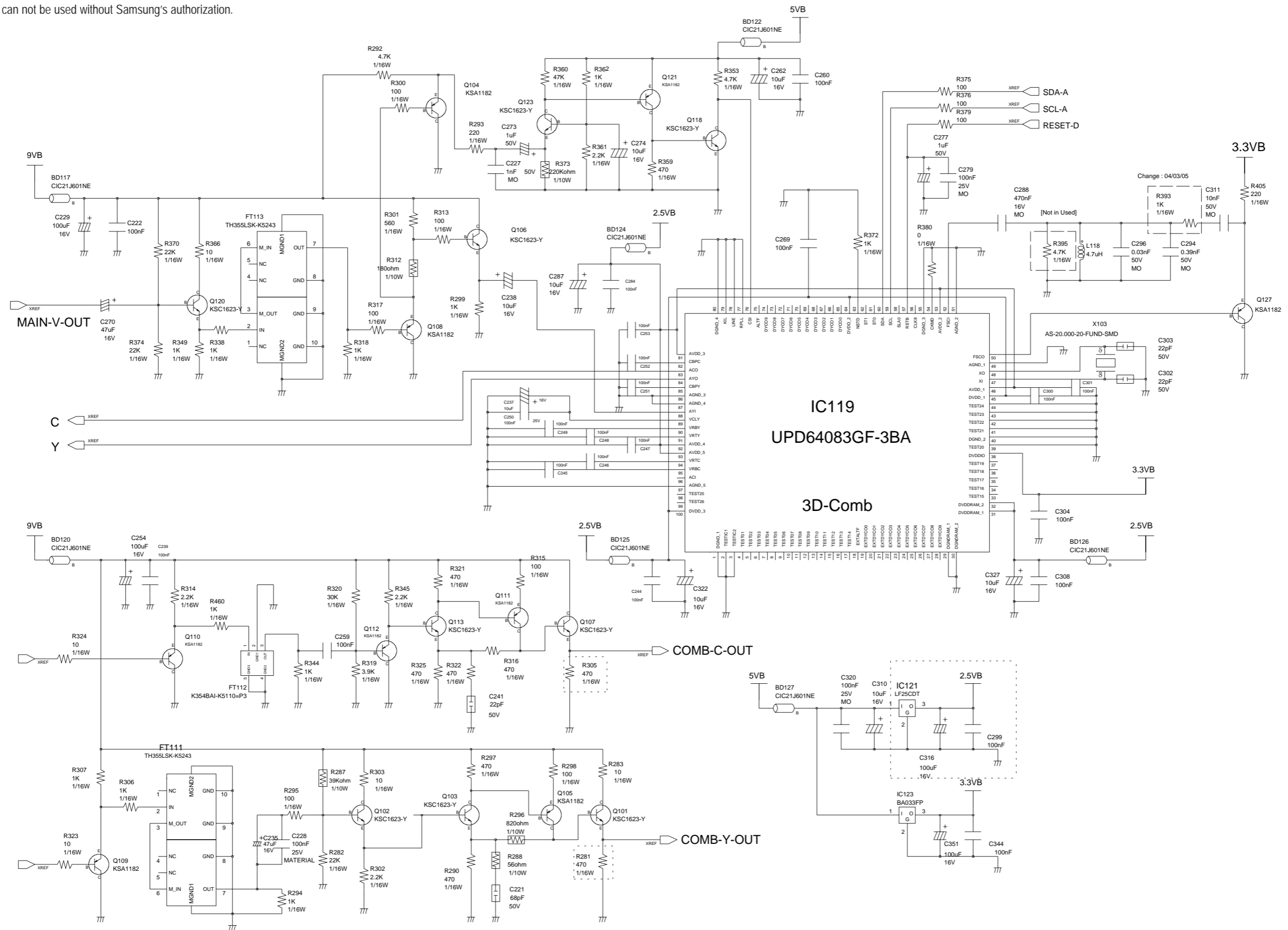

10-1-7 Sound Processor/Amp

This Document can not be used without Samsung's authorization.

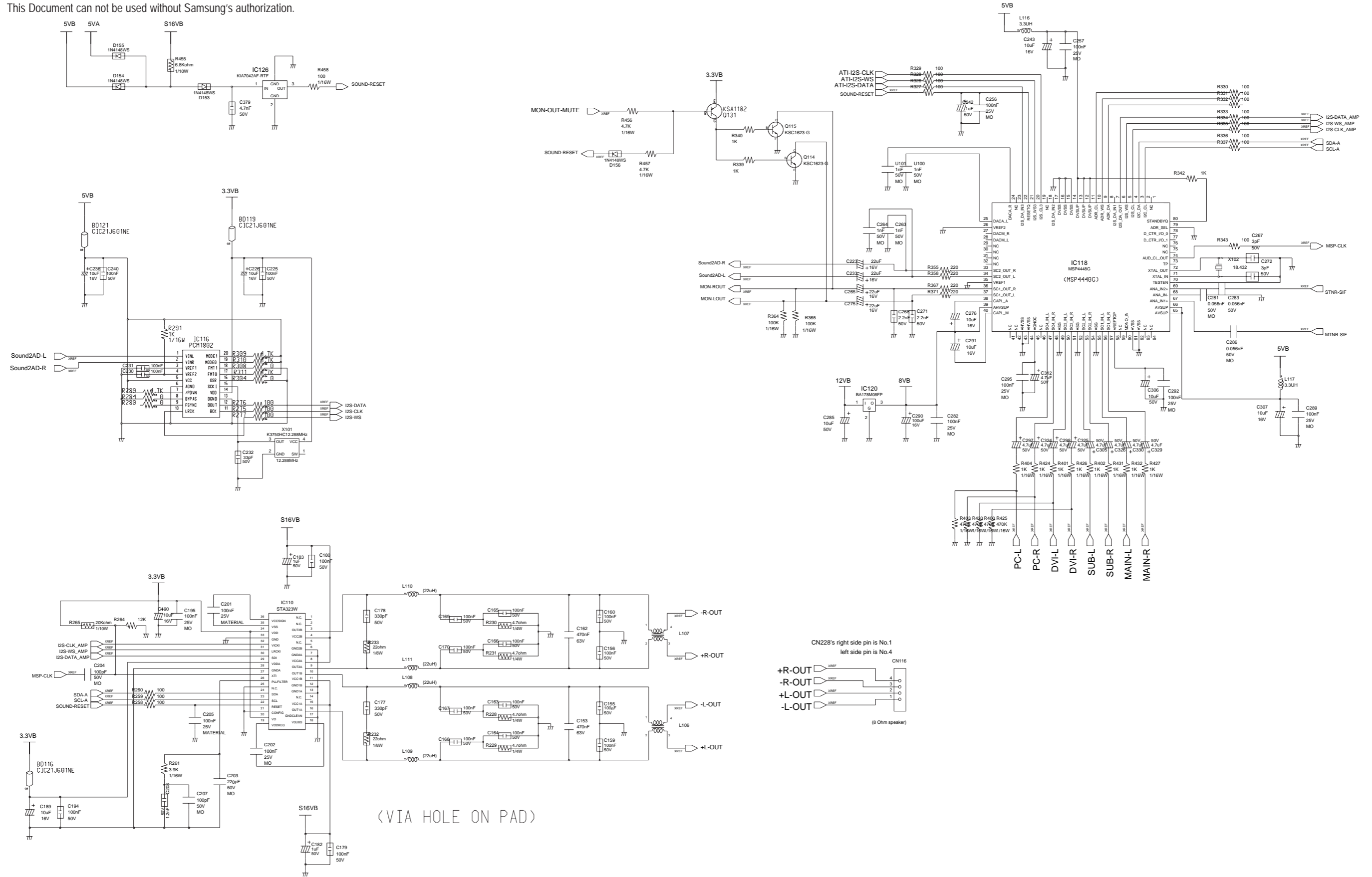

10-1-8 S3F84BB_Micom

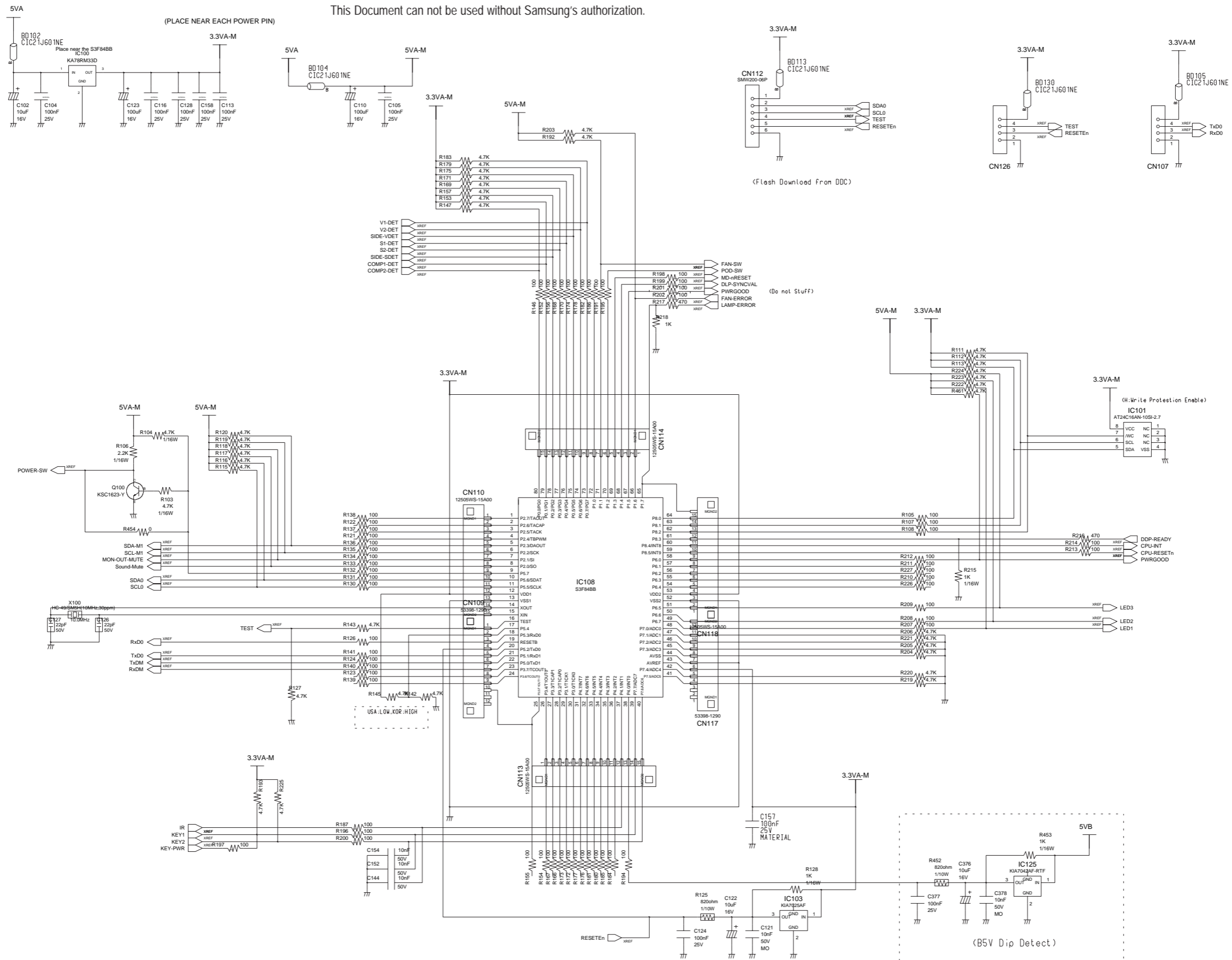

10-1-9 Signal Connection

This Document can not be used without Samsung's authorization.

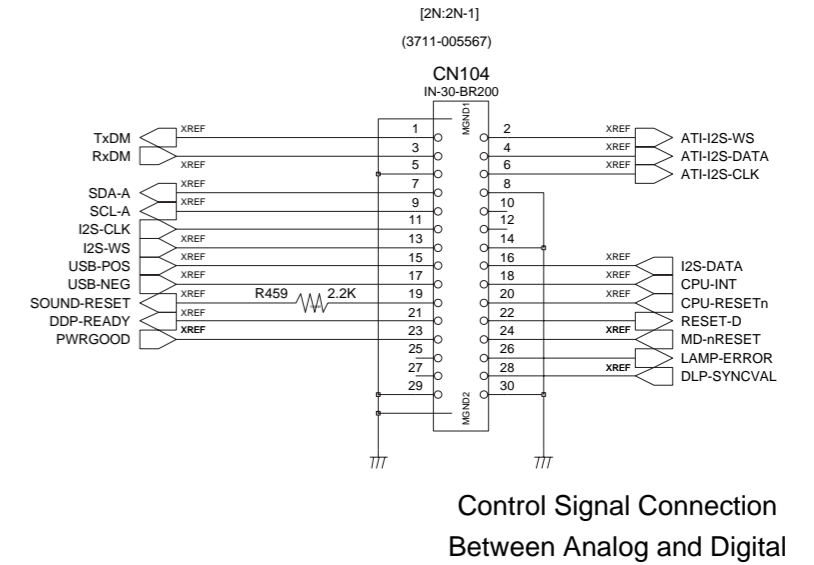
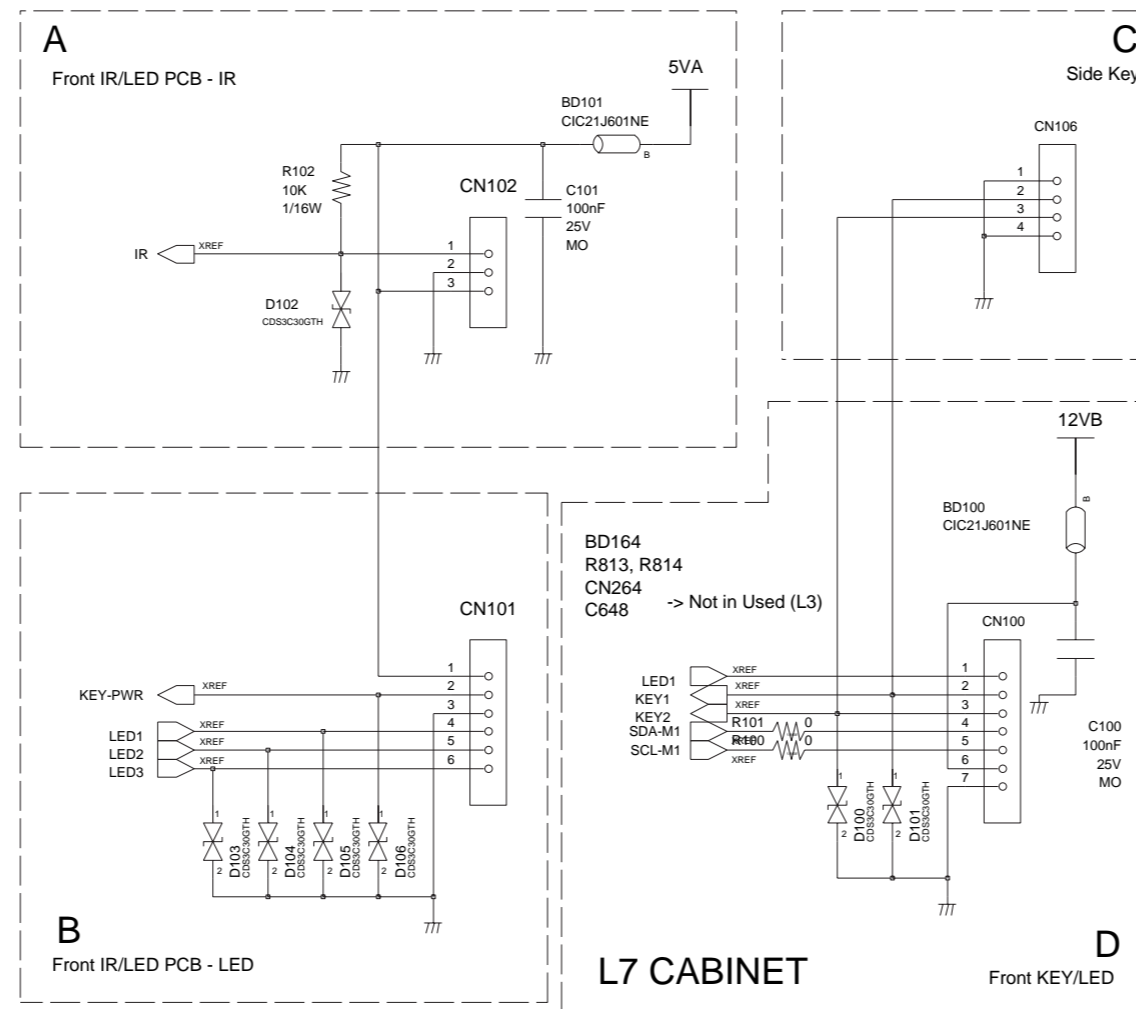
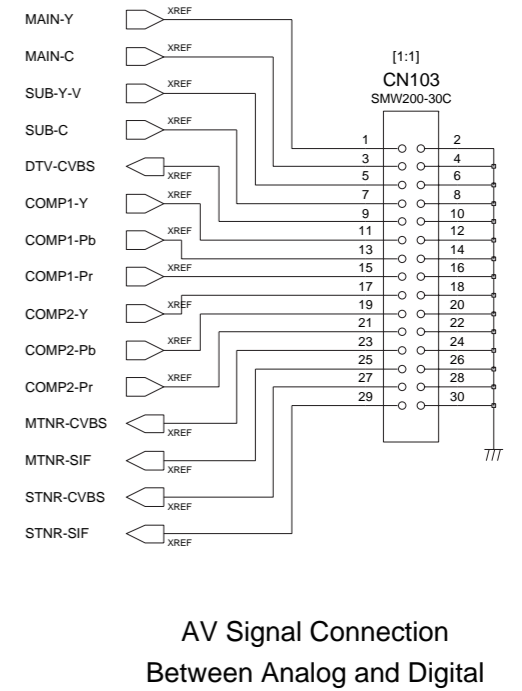
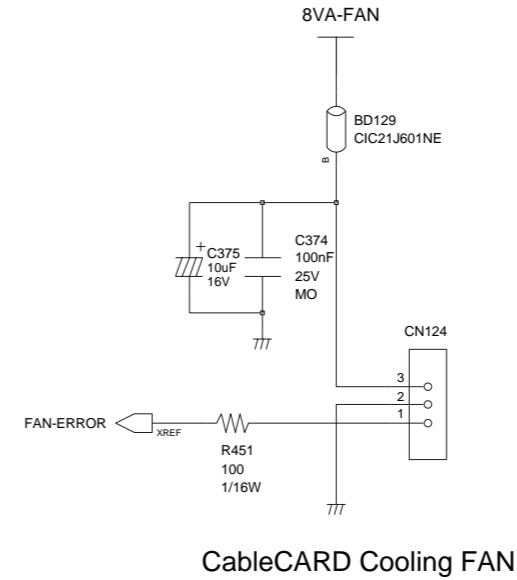
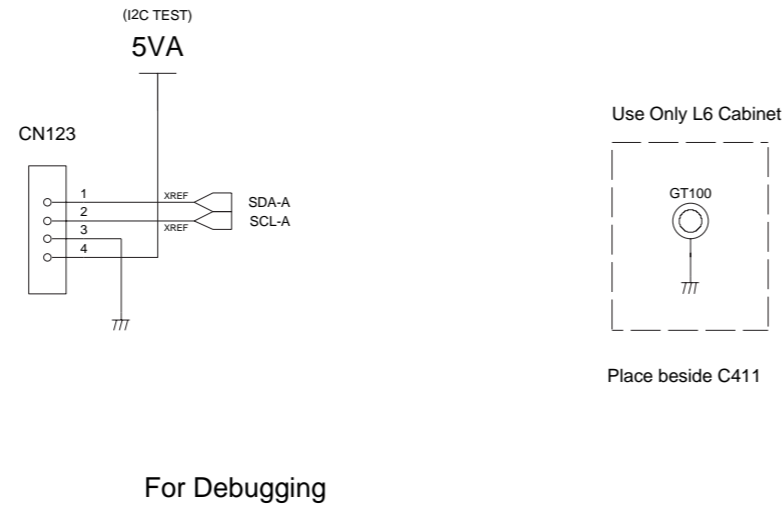
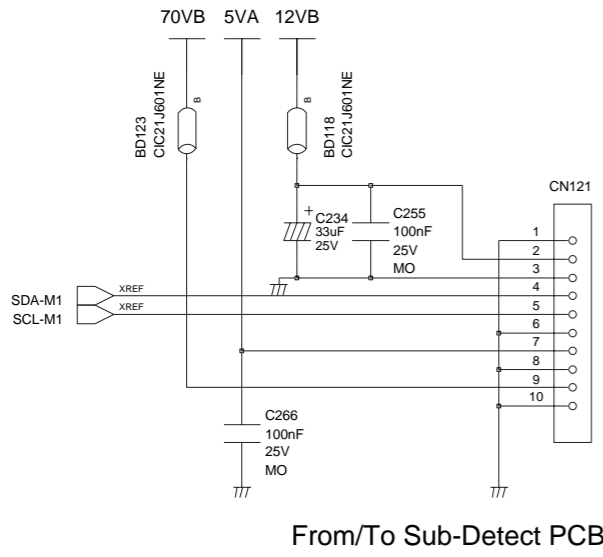

10-2-2 DTV Module-2

This Document can not be used without Samsung's authorization.

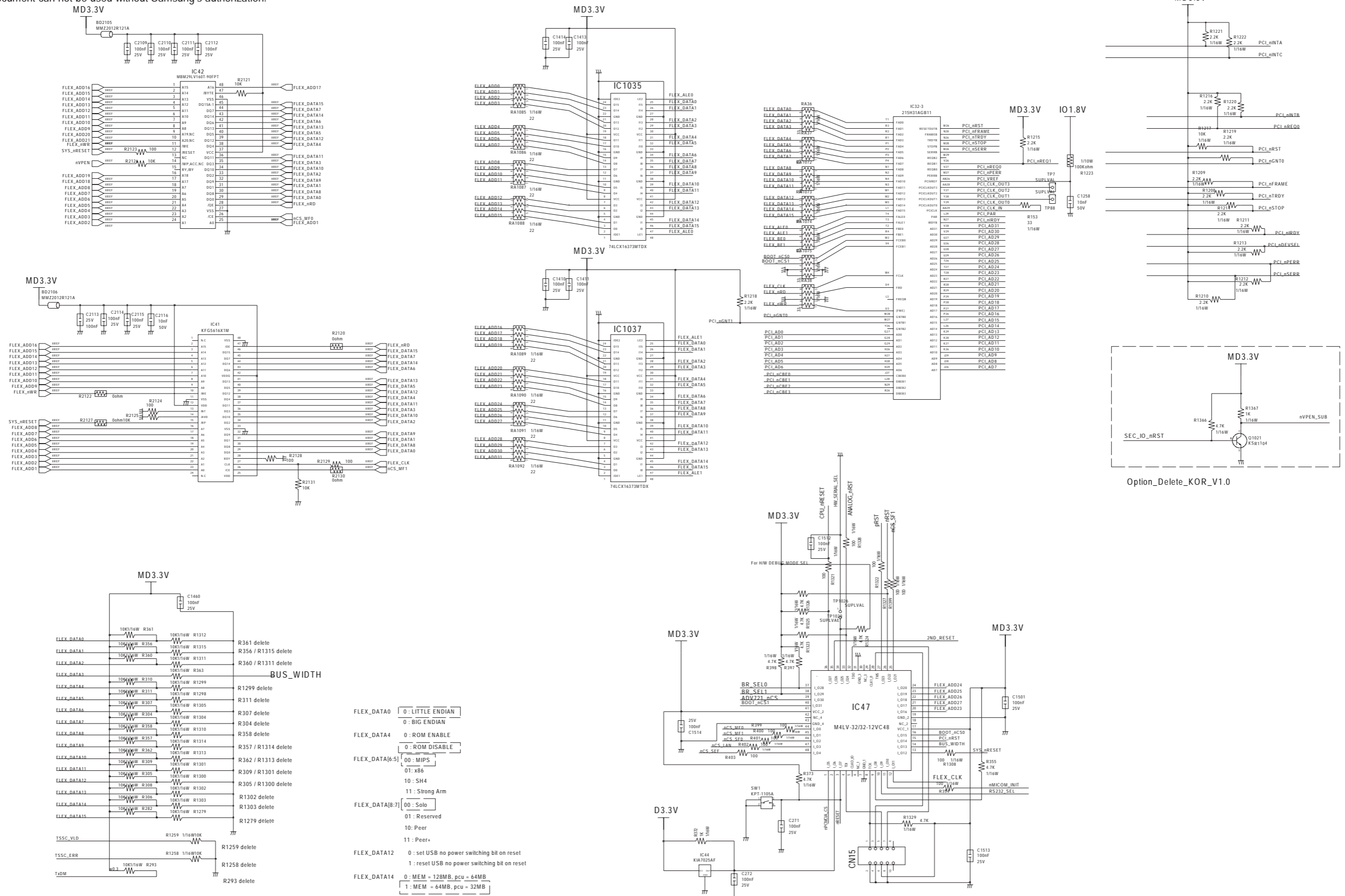

Option_Delete_KOR_V1.0

10-2-3 DTV Module-3

This Document can not be used without Samsung's authorization.

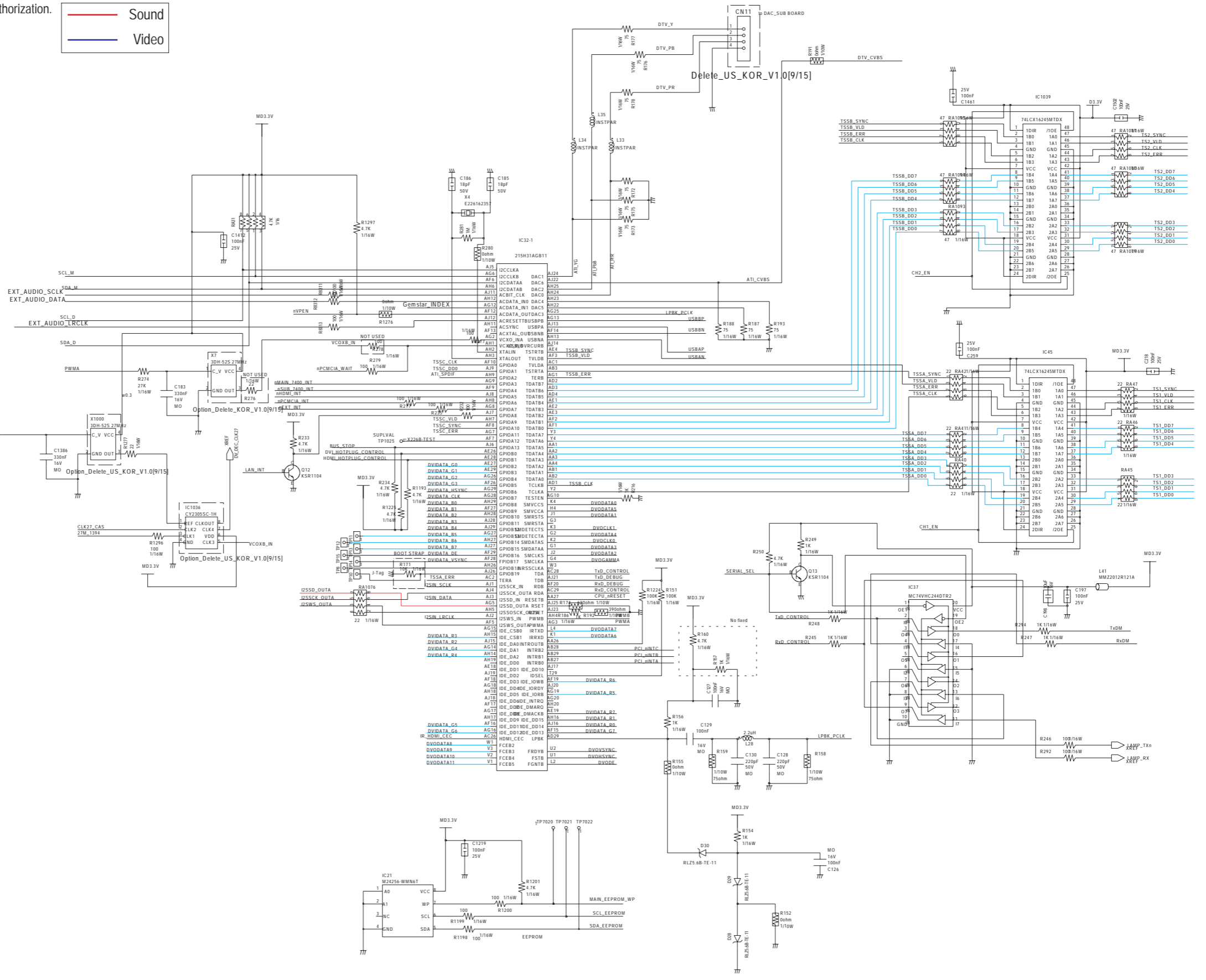
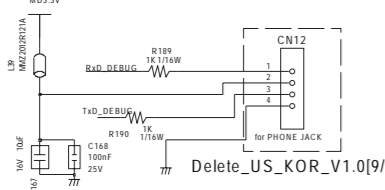
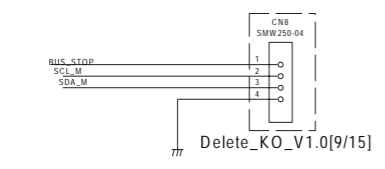
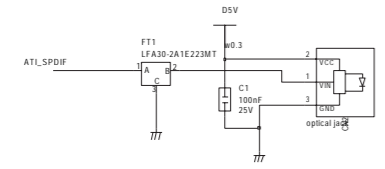

10-2-4 DTV Module-4

This Document can not be used without Samsung's authorization.

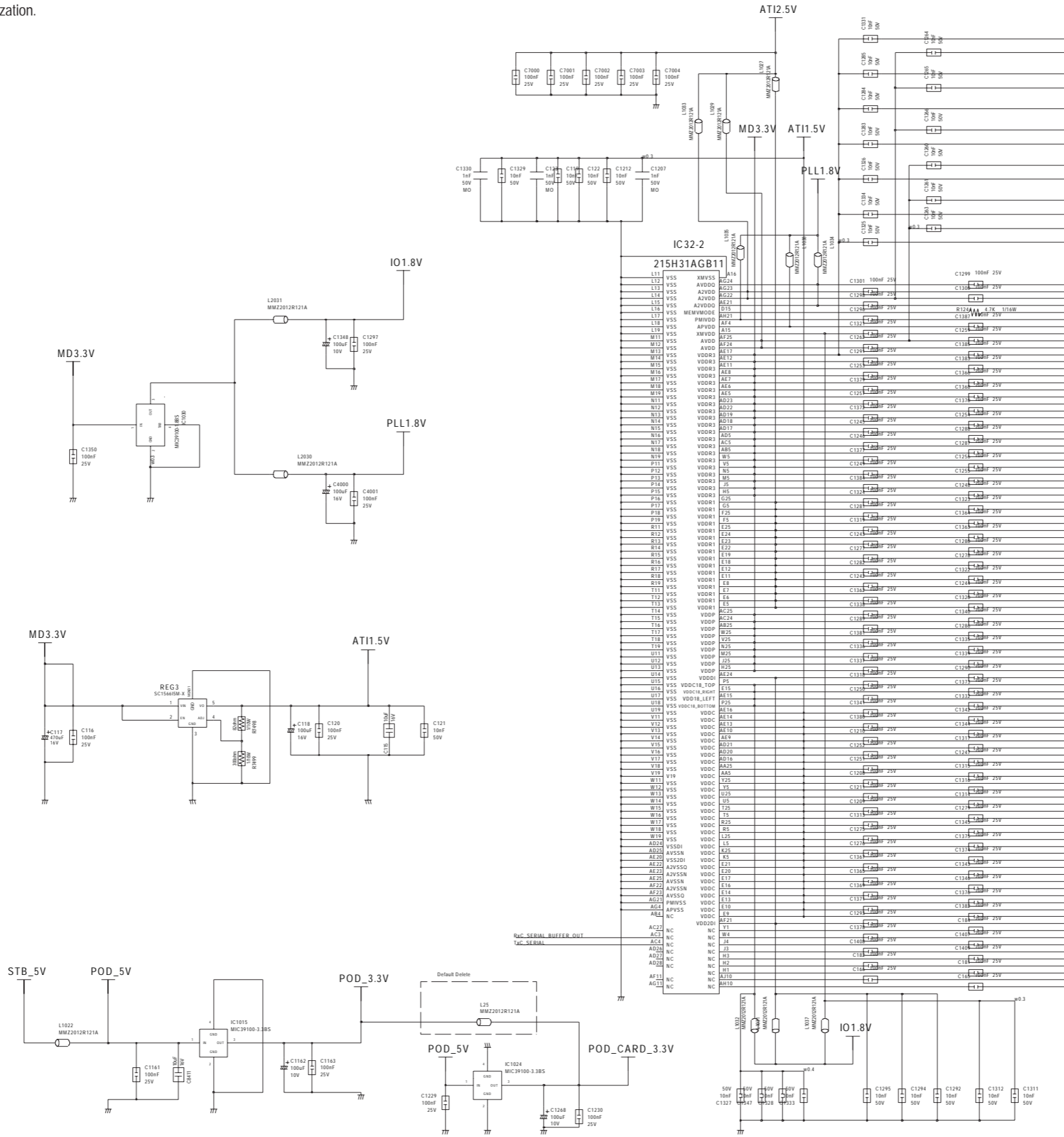

10-2-6 DTV Module-6

This Document can not be used without Samsung's authorization.

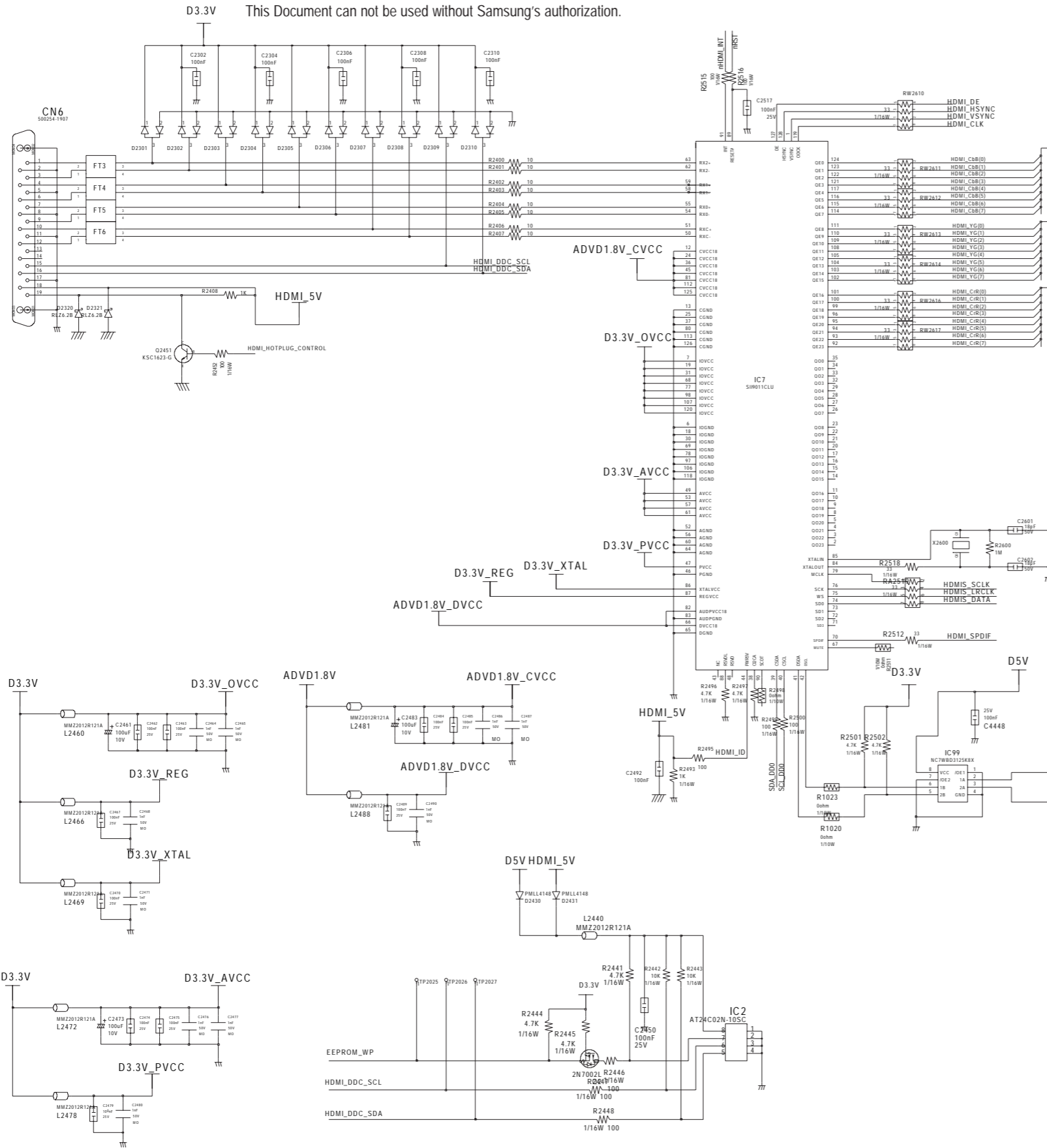

Option default add

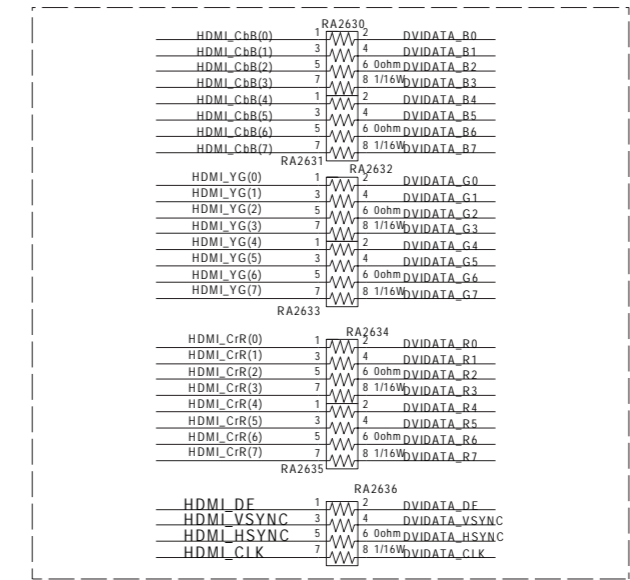
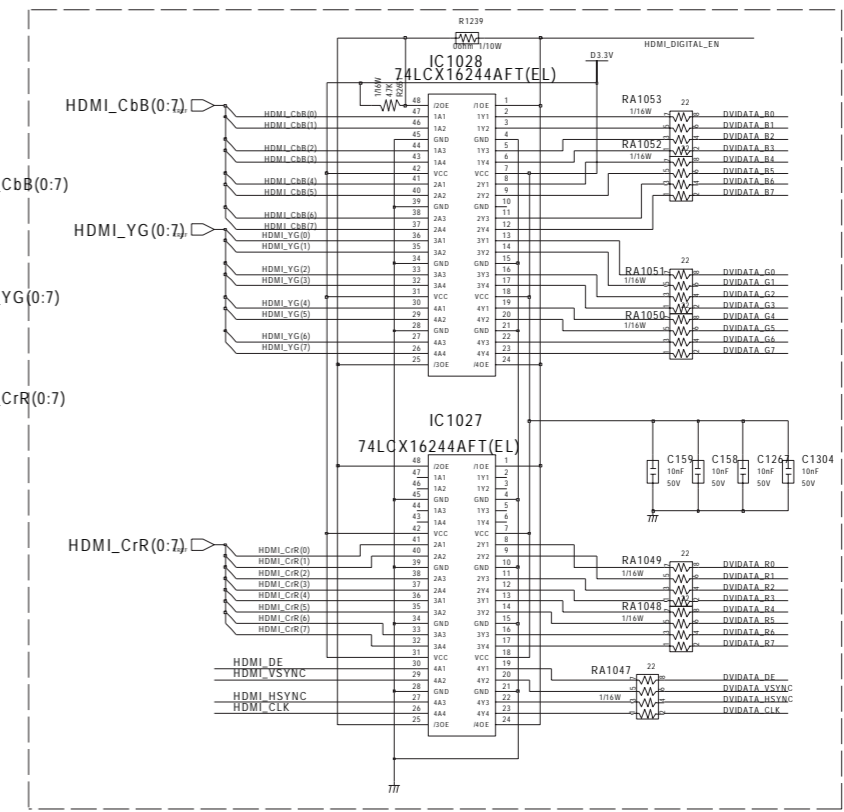

Option default delete

10-2-7 DTV Module-7

This Document can not be used without Samsung's authorization.

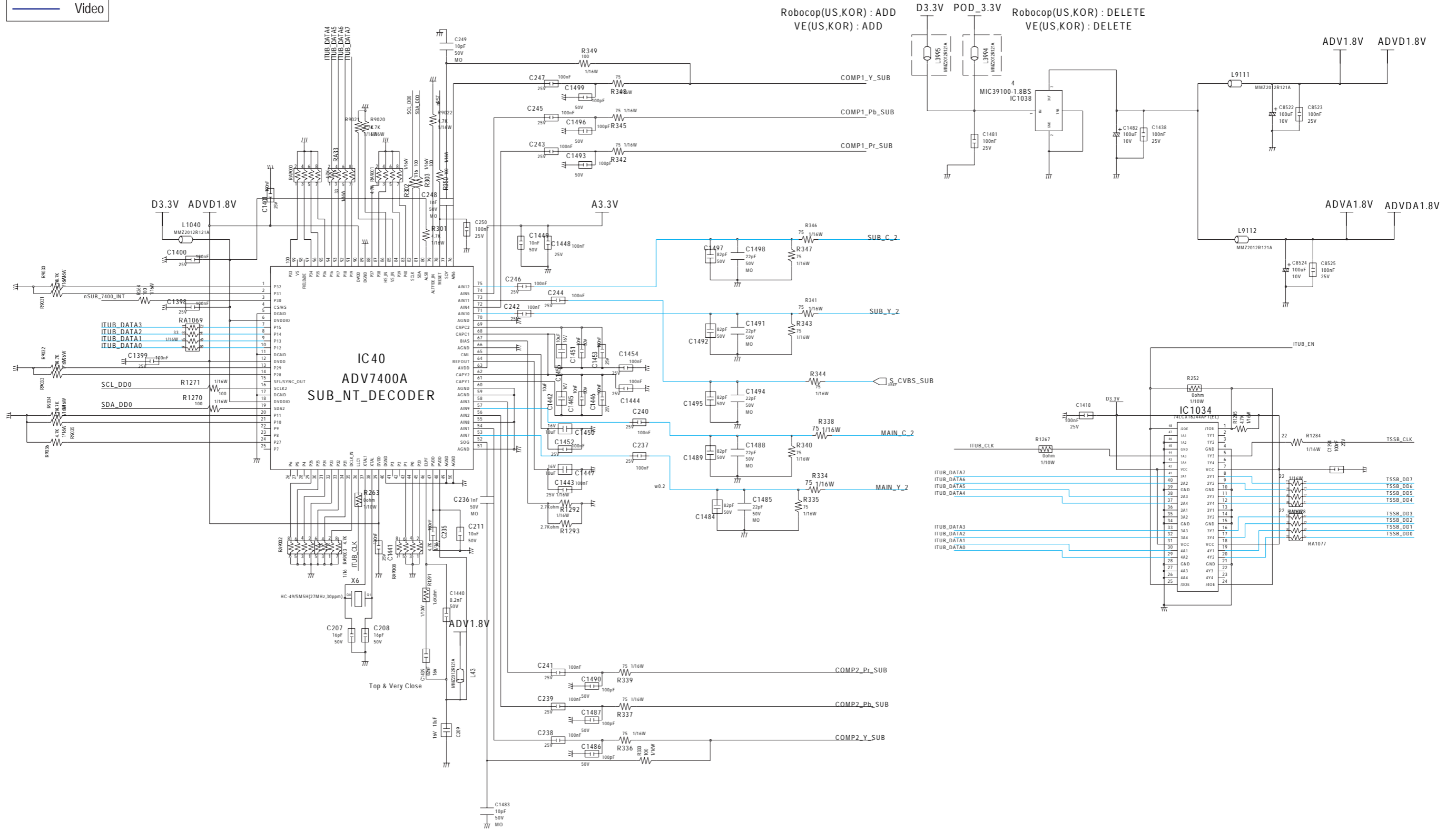

Robocop(US,KOR) : ADD
VE(US,KOR) : ADD

Robocop(US,KOR) : DELETE
VE(US,KOR) : DELETE

10-2-8 DTV Module-8

This Document can not be used without Samsung's authorization.

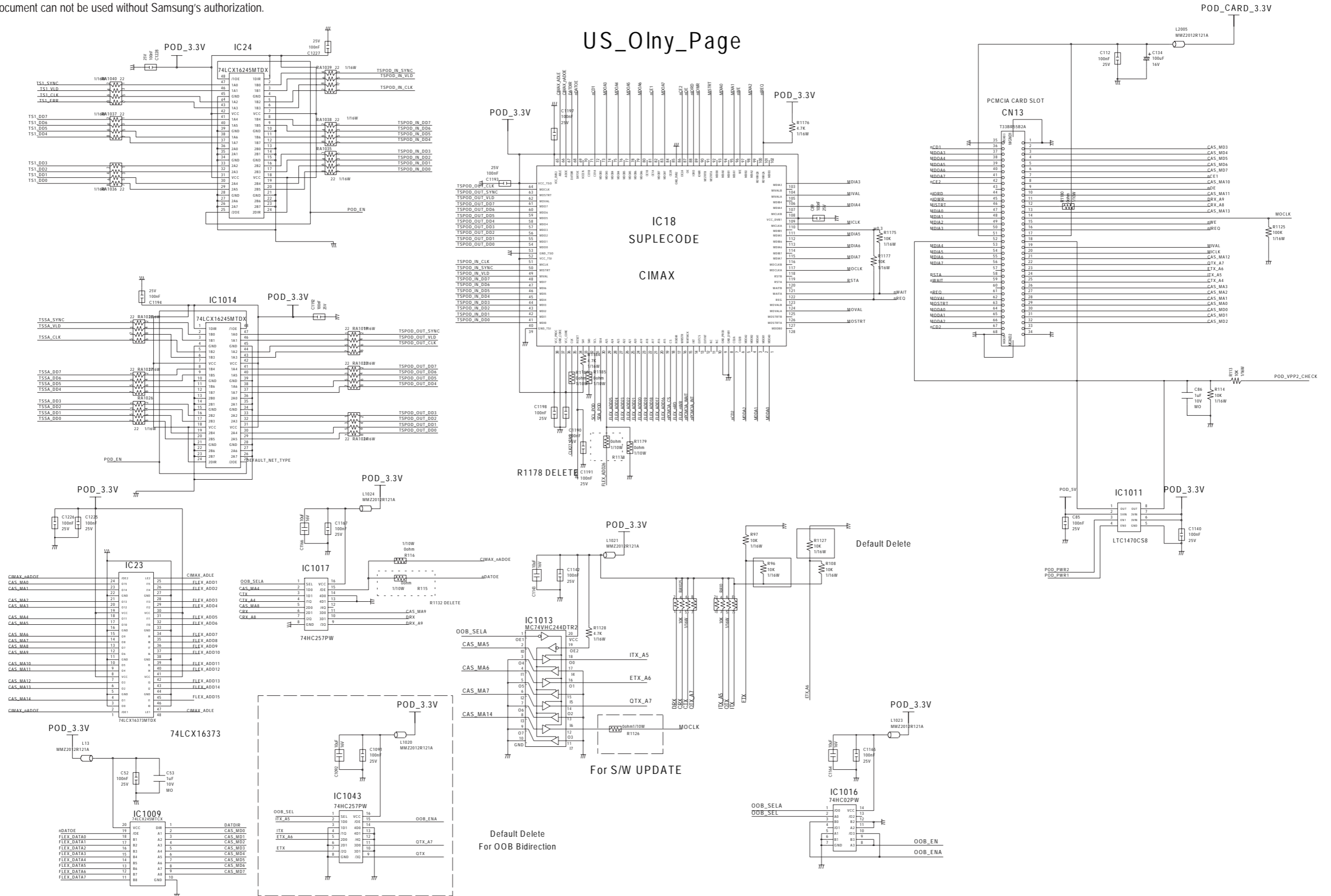

10-2-10 DTV Module-10

This Document can not be used without Samsung's authorization.

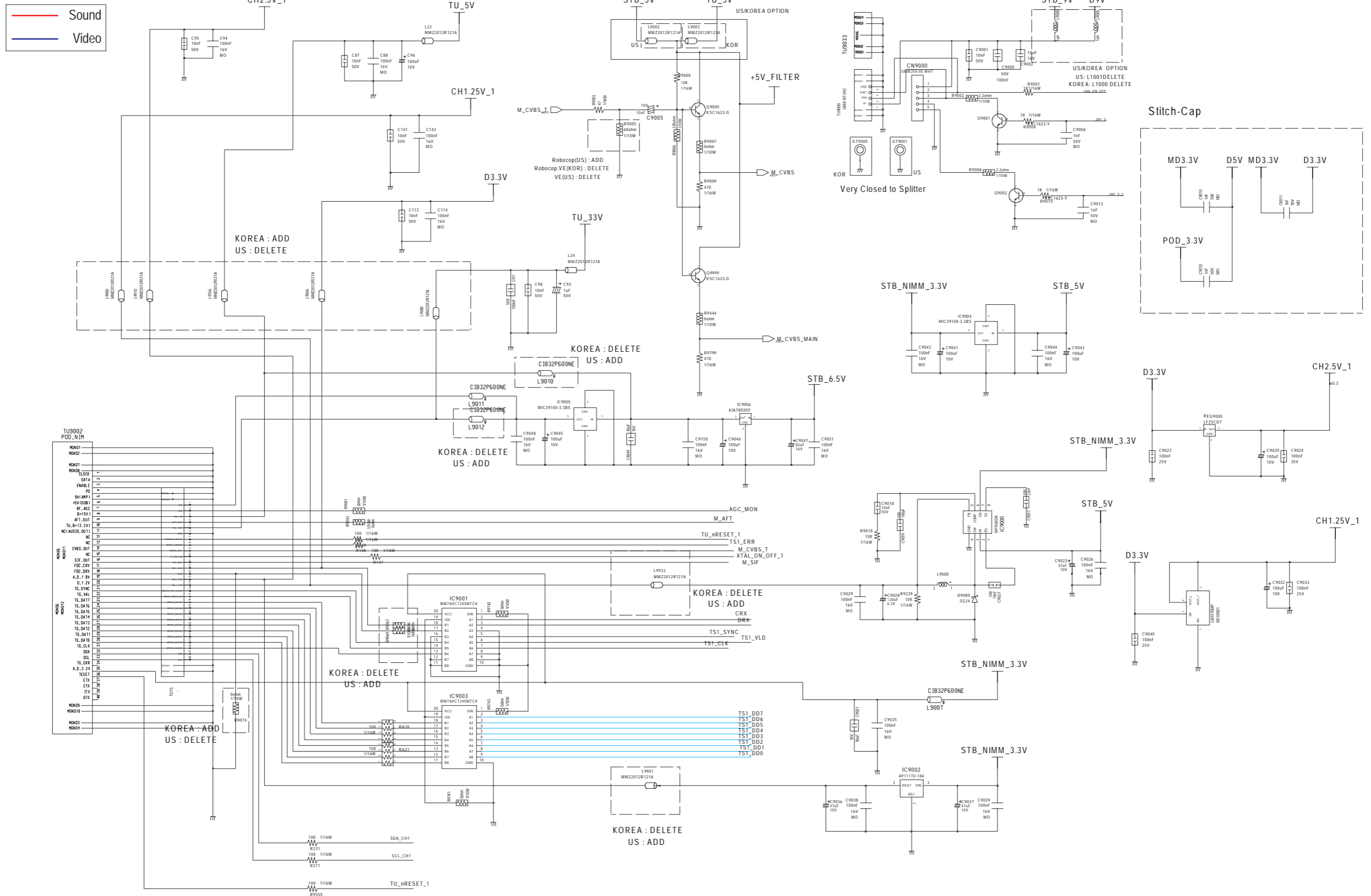

10-2-12 DTV Module-12

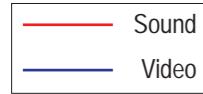

This Document can not be used without Samsung's authorization.

Delete_US_KOR_V1.0

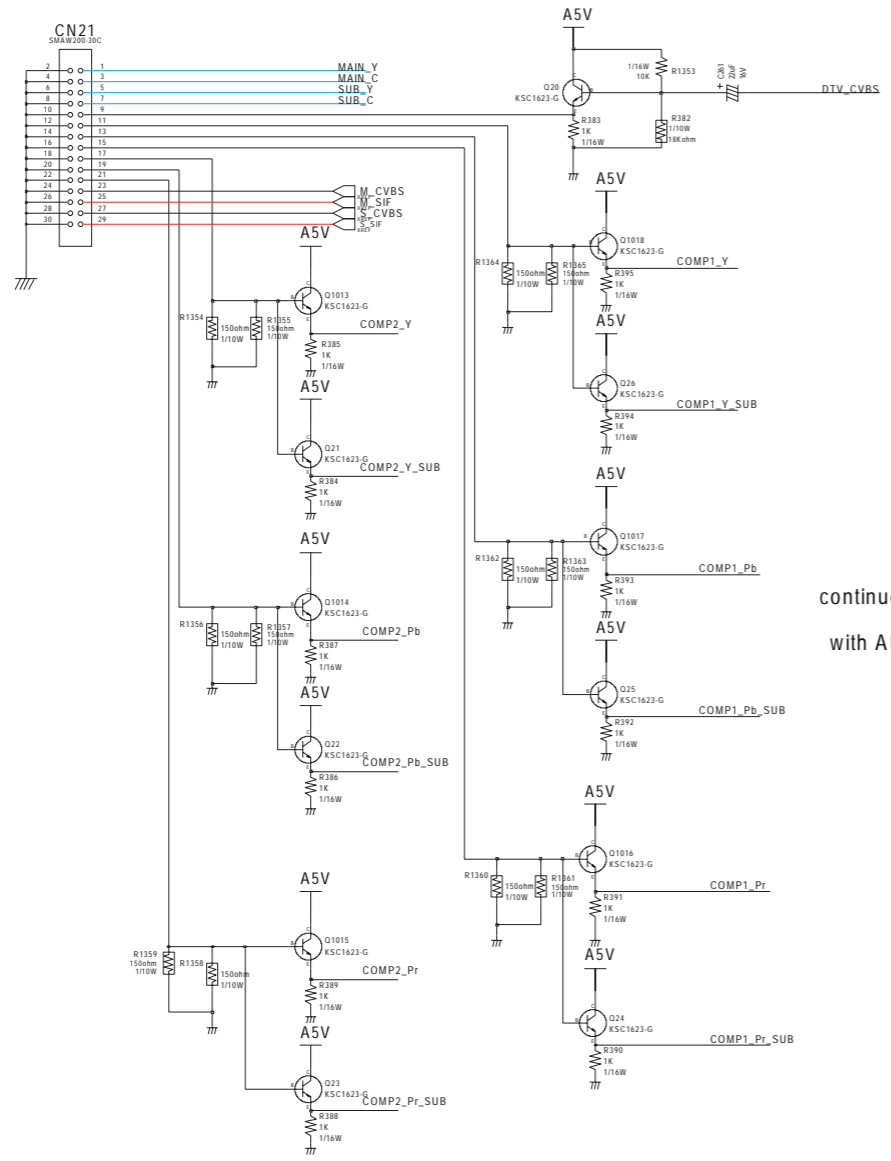
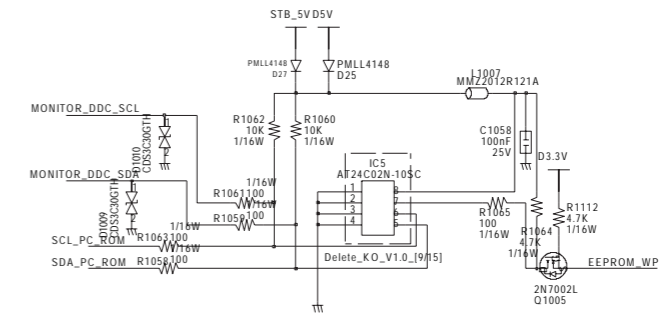
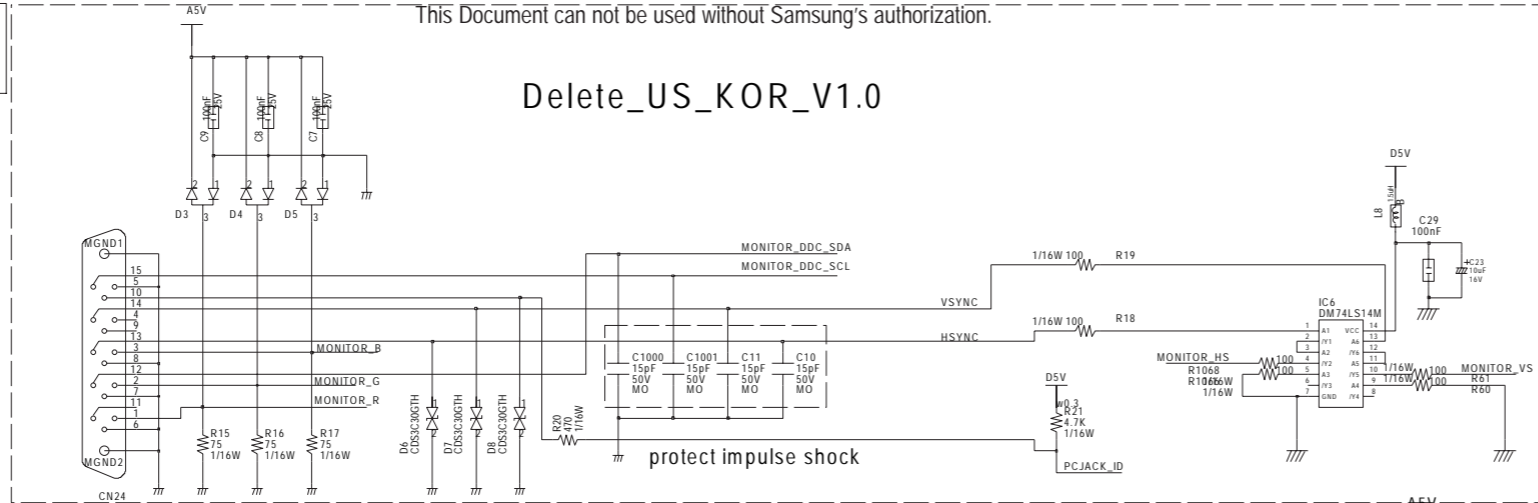

continue # 14 - 13
with ADV7402

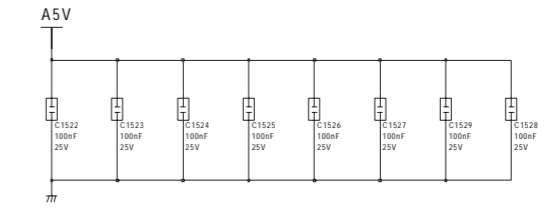
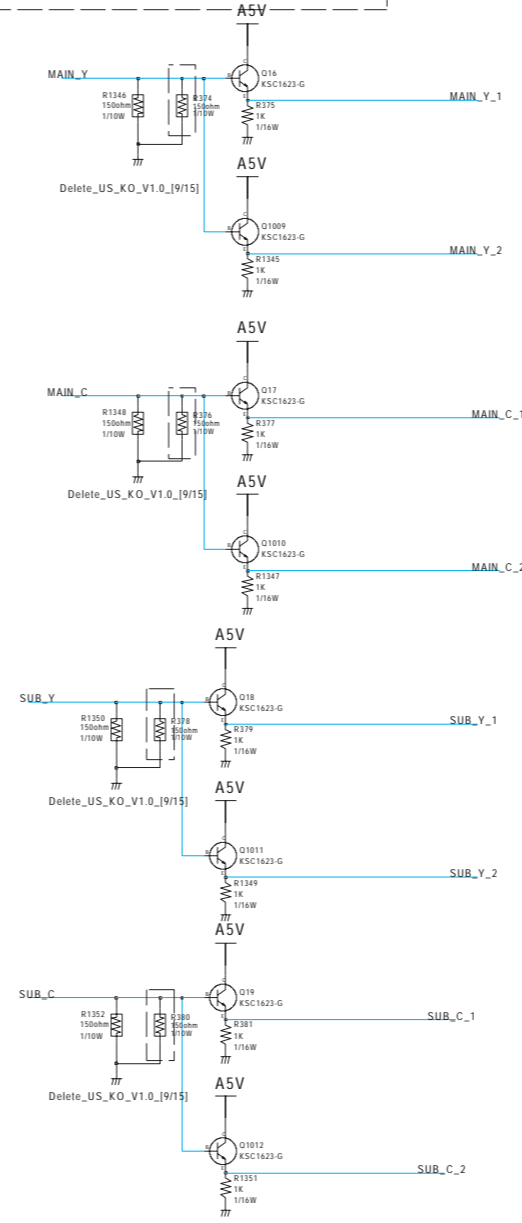

10-2-14 DTV Module-14

This Document can not be used without Samsung's authorization.

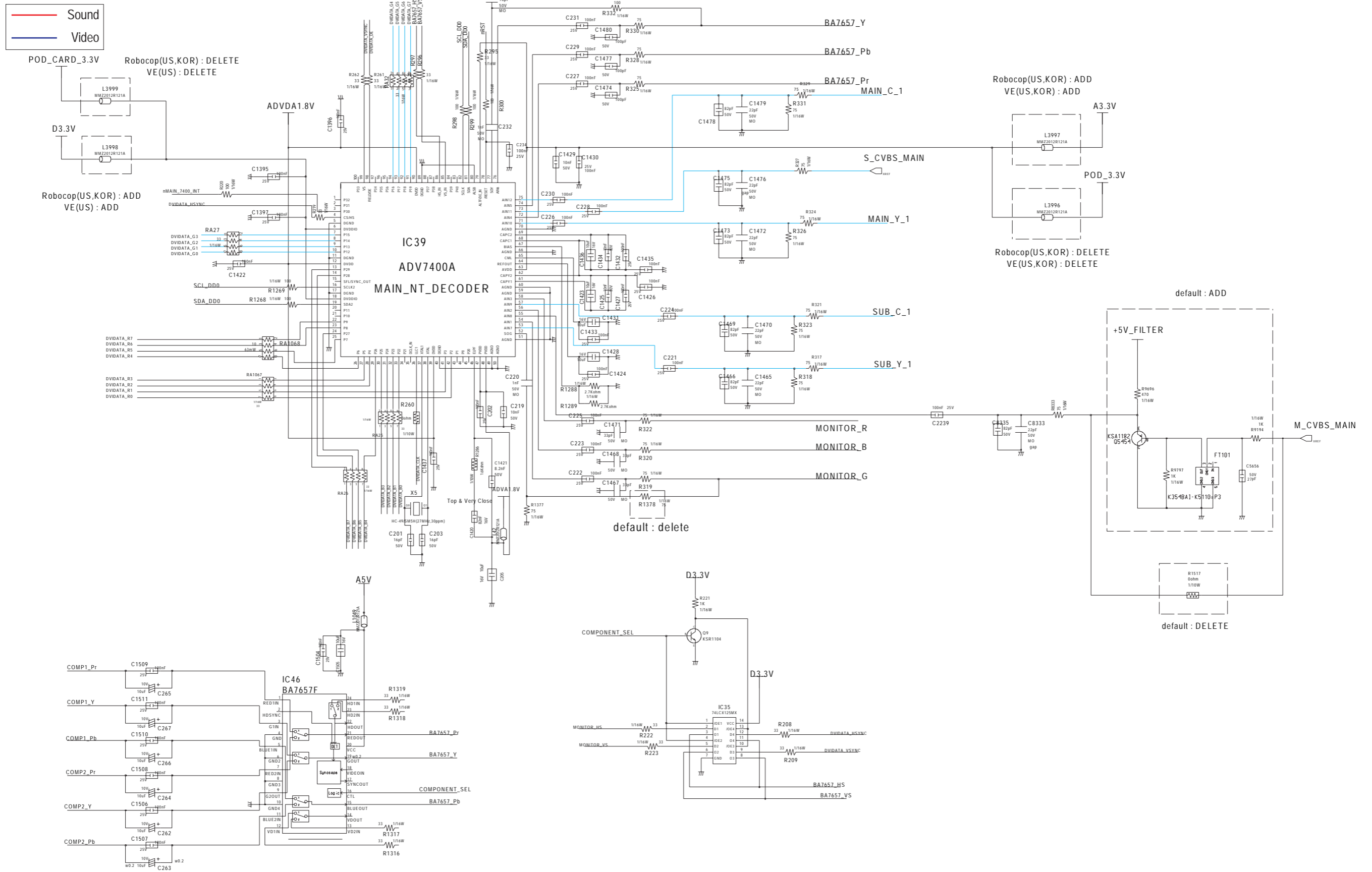

10-2-15 DTV Module-15

This Document can not be used without Samsung's authorization.

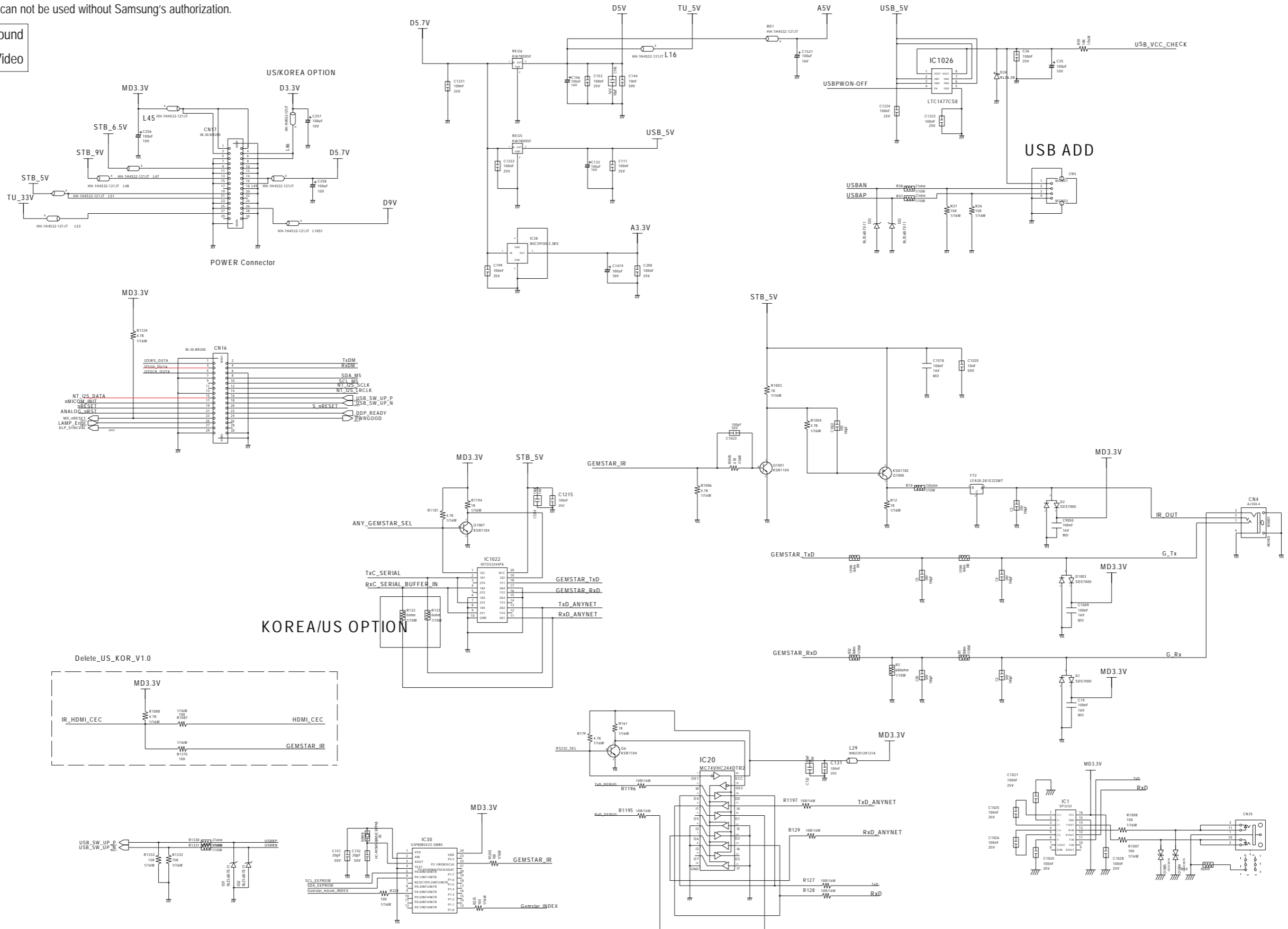

10-2-16 DTV Module-16

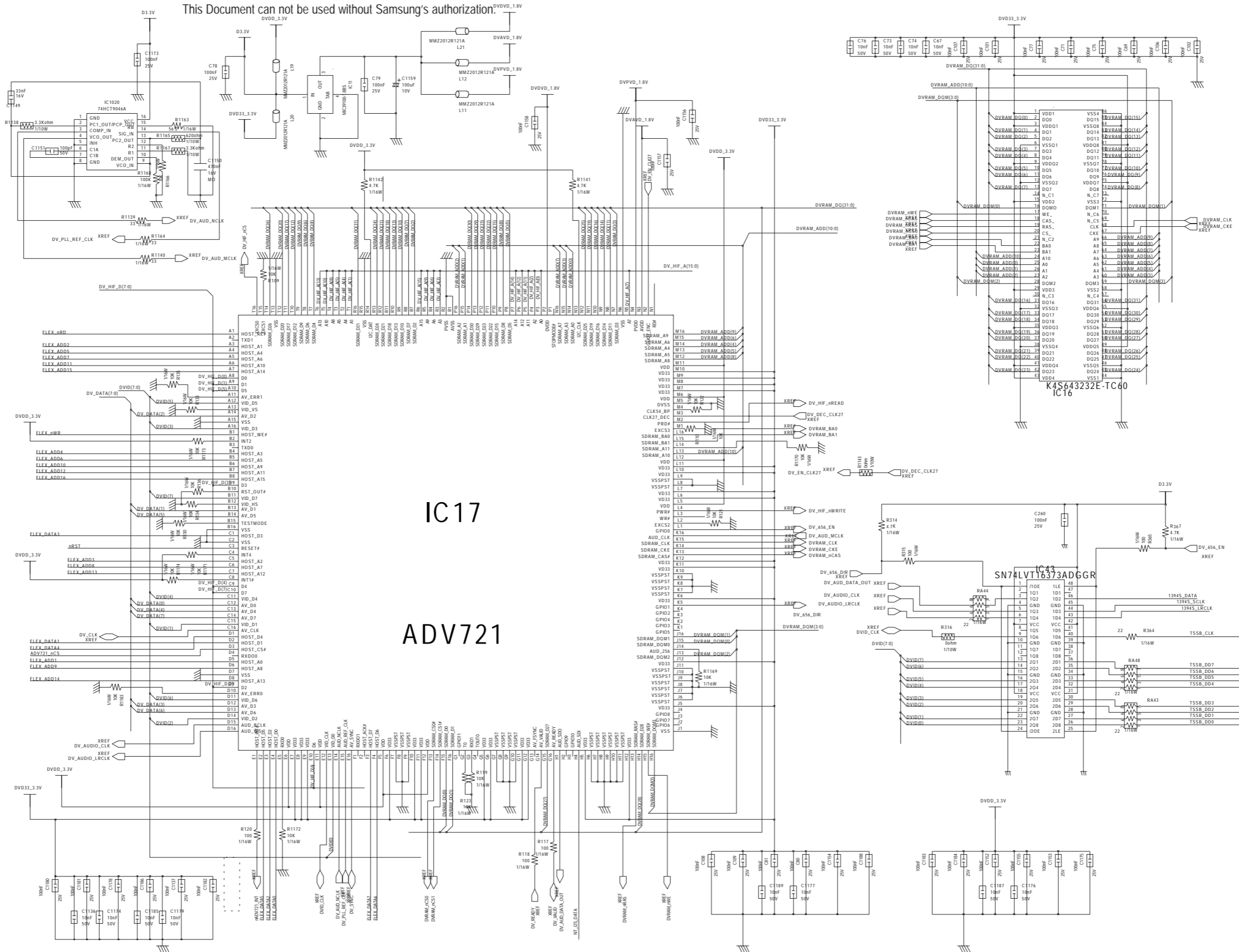

IC17
ADV721

K4S643232E-TC40
IC16

10-2-17 DTV Module-17

This Document can not be used without Samsung's authorization.

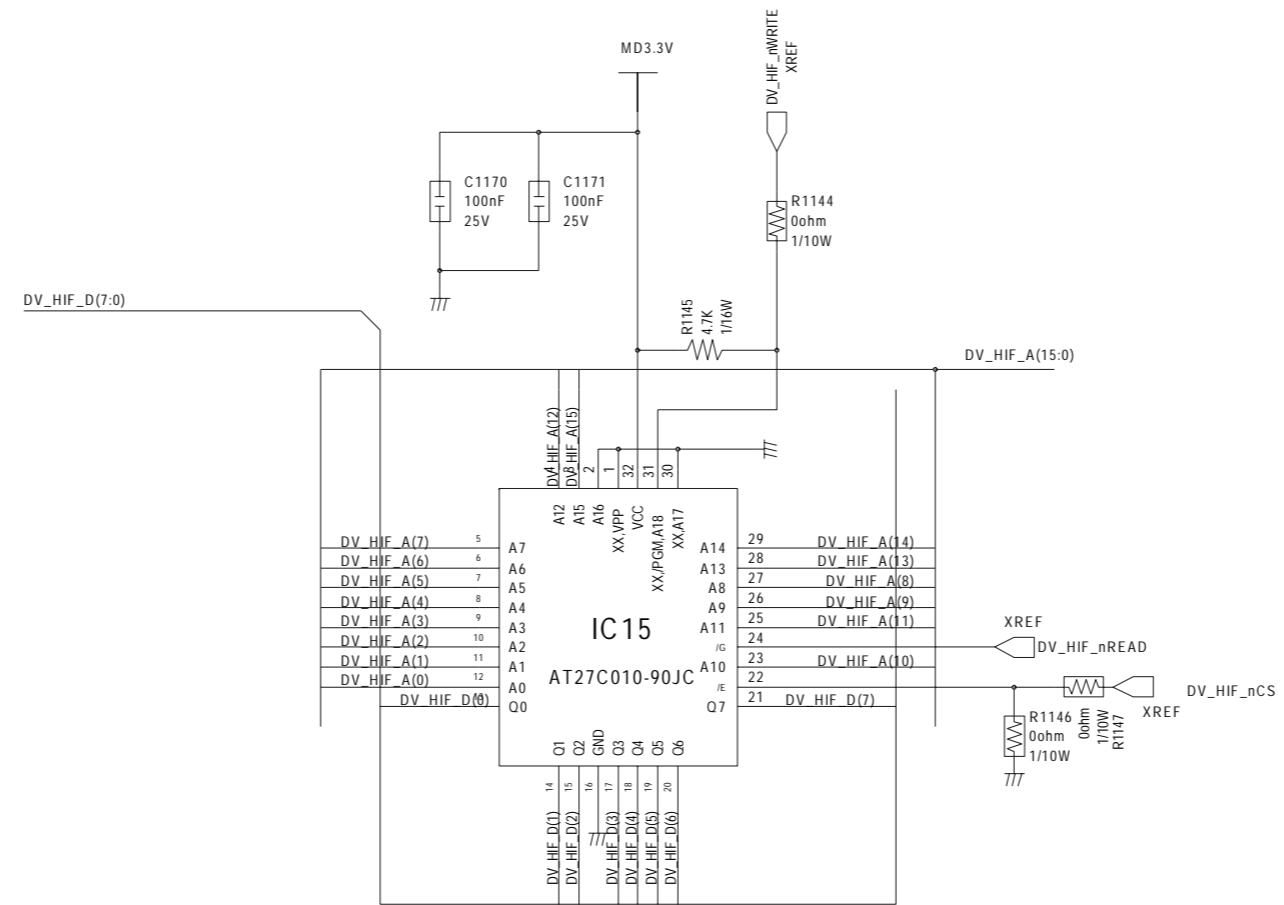

10-2-18 DTV Module-18

This Document can not be used without Samsung's authorization.

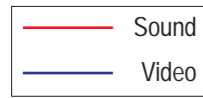

KO Olmy - Sub alps NIM tuner

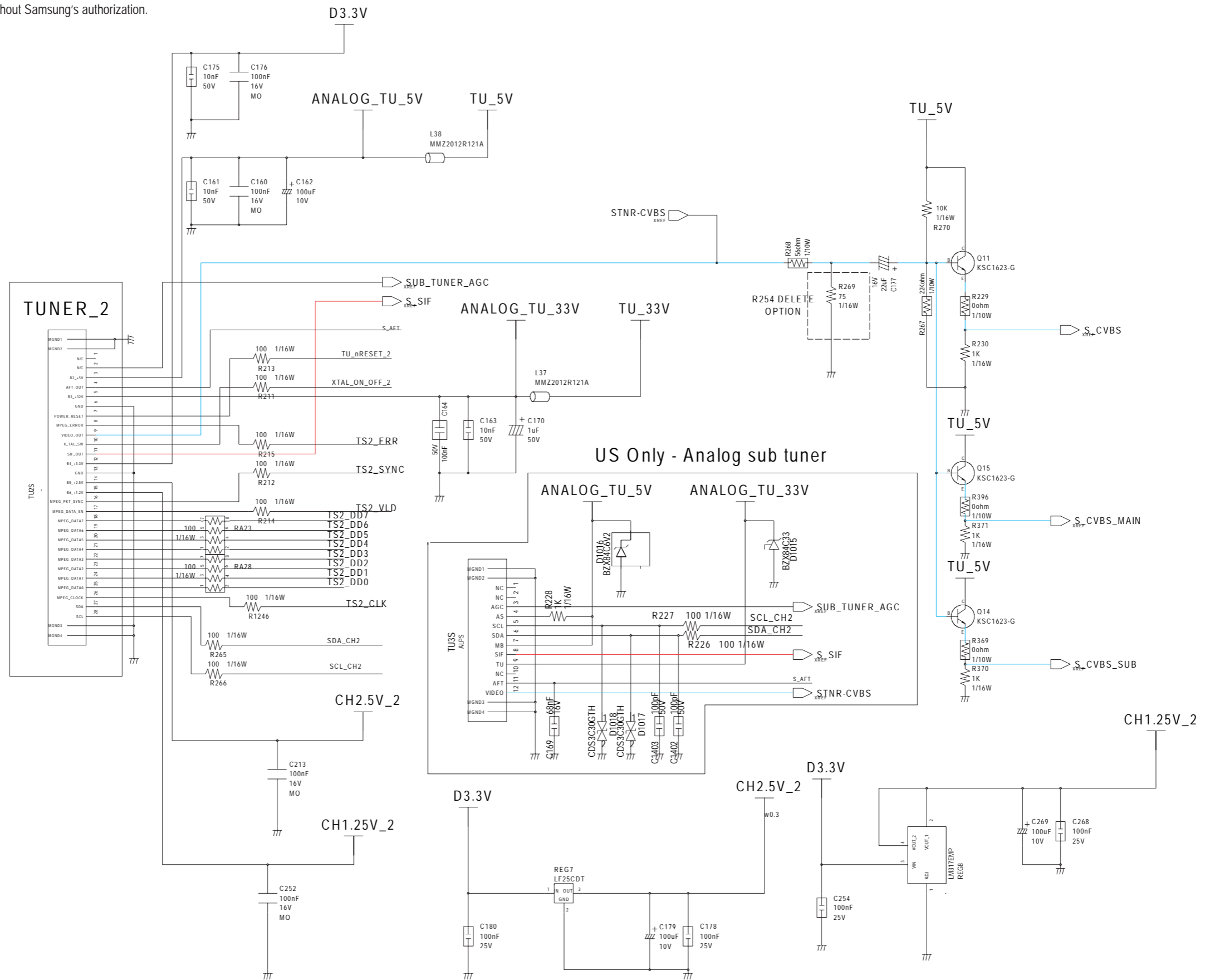

10-3 DMD Board

10-3-1 DMD Board-1

This Document can not be used without Samsung's authorization.
 (DDP1011 CONTROL OPTION FROM PC)

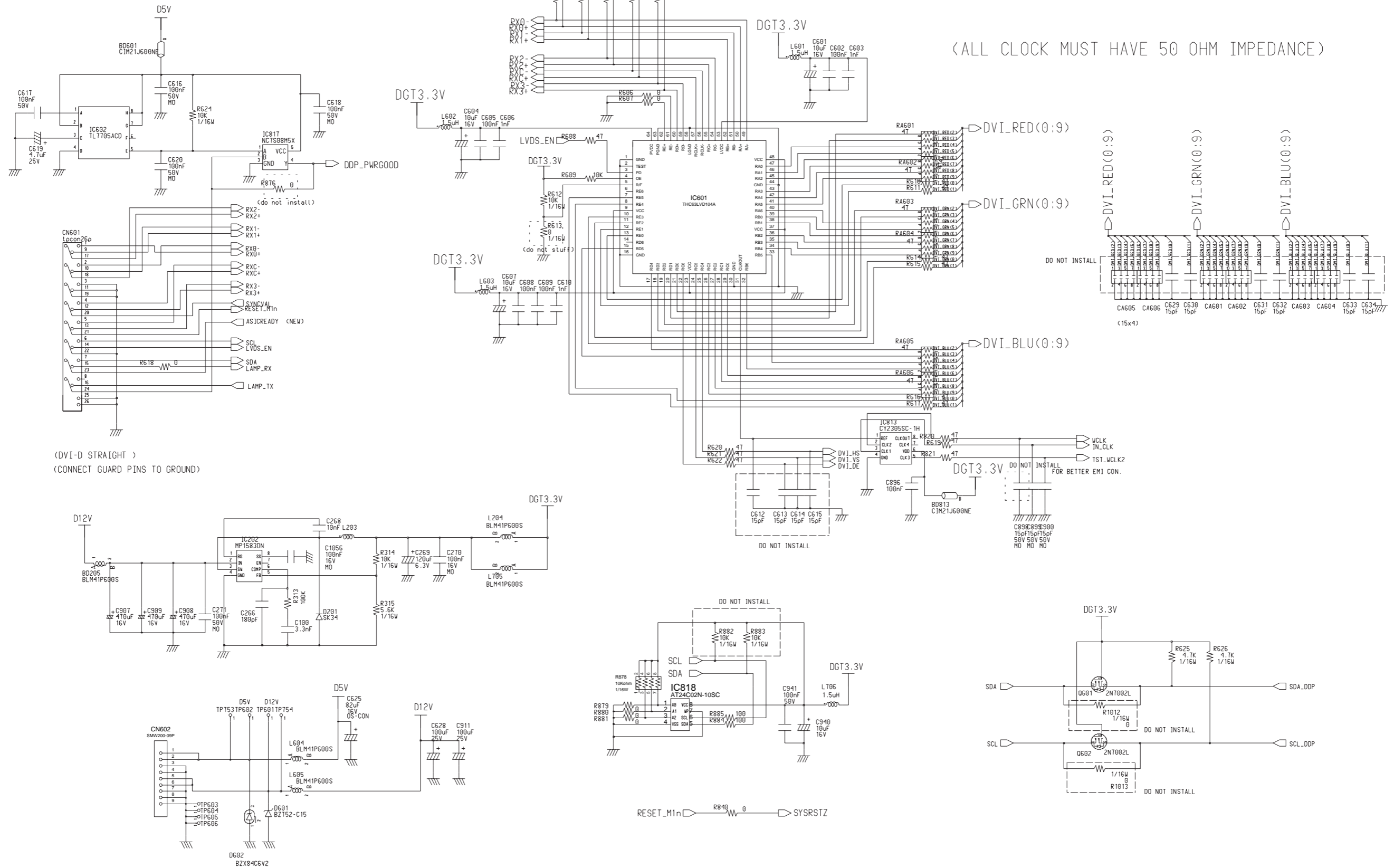

10-3-2 DMD Board-2

This Document can not be used without Samsung's authorization.

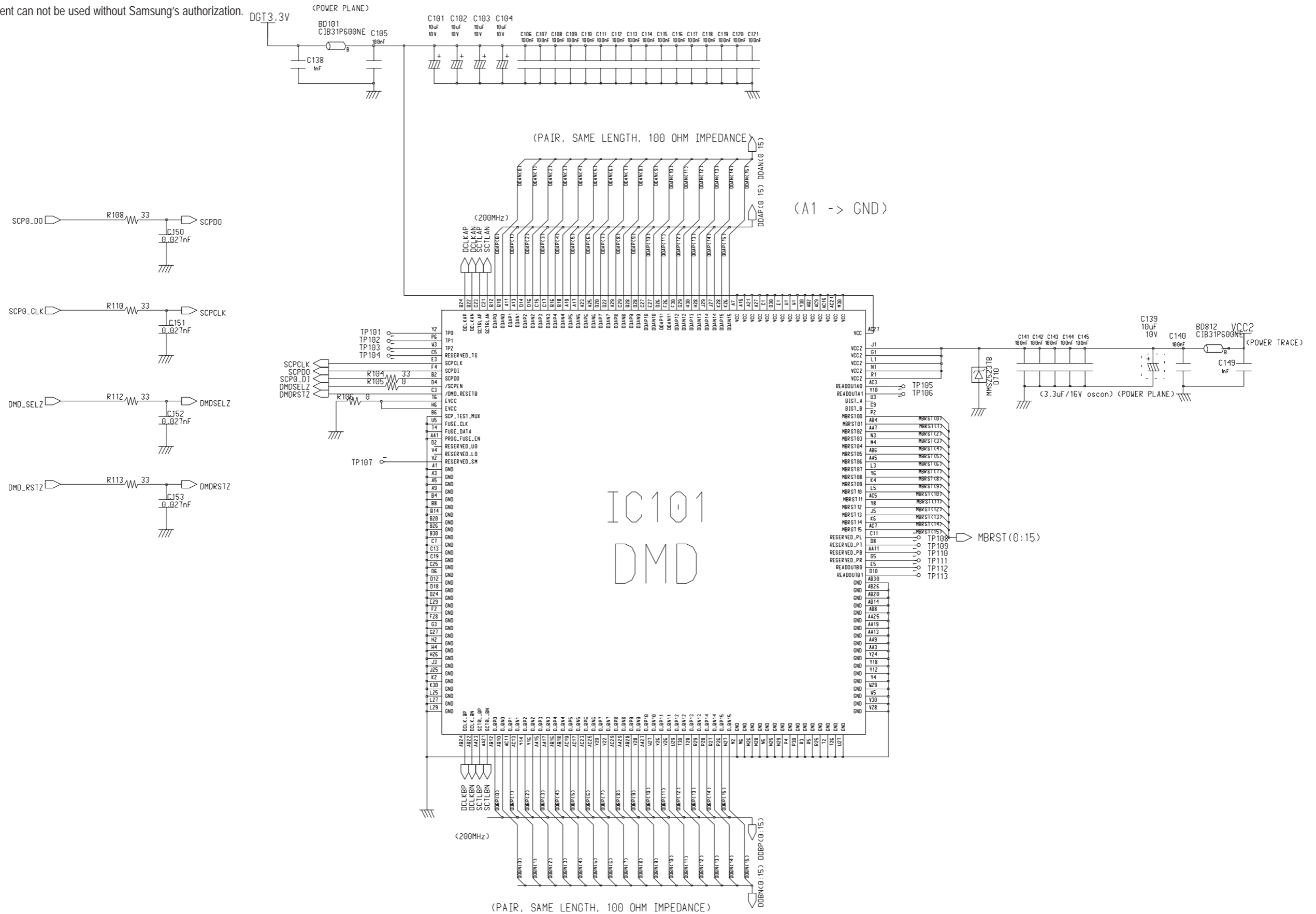

10-3-3 DMD Board-3

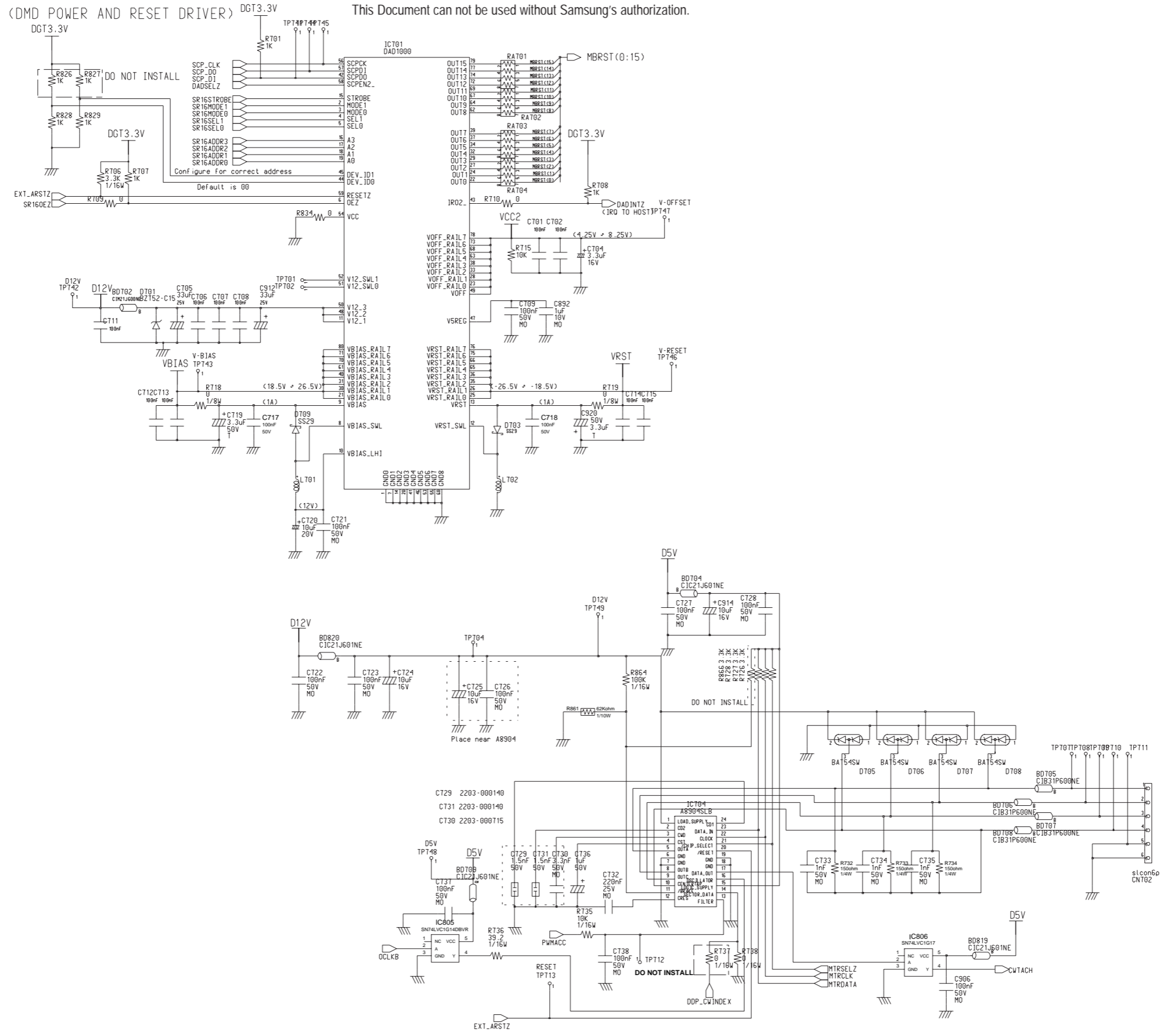

10-3-4 DMD Board-4

This Document can not be used without Samsung's authorization.

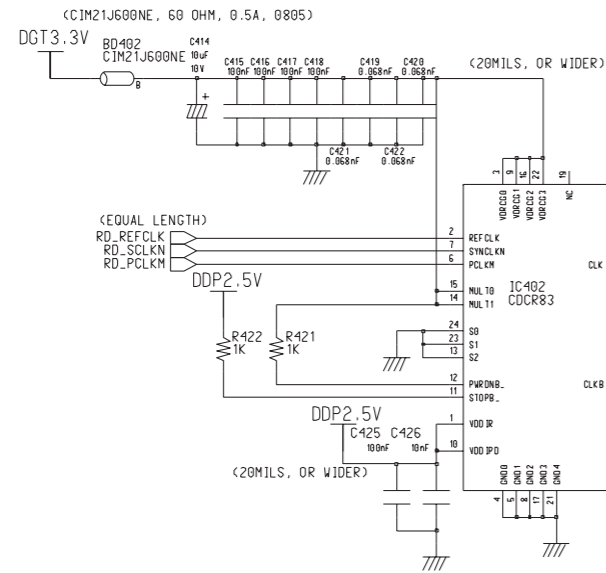
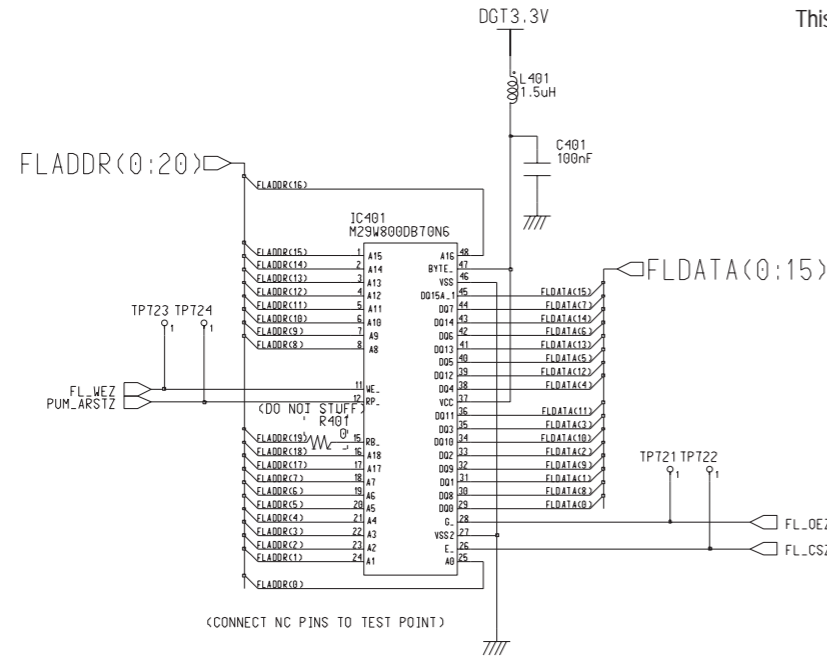

<PAIR, IMPEDANCE: UNLOADED :40 OHM, LOADED:60.6 OHM>
 <ROUTING: CDCR83-> RDRAM(CTM) -> DDP1010(CFM) -> RDRAM -> TERMINATION RESISTOR)>
 <RSL : RD(0:7), RQA(0:8), ROB(0:8), RD_CTM, RD_CTMN, RD_CFM, RD_CFMN, RD_CMD, RD_SCK)>
 <50 OHM IMPEDANCE : RD_REFCLK, RD_SCLKN, RD_PCLKN)>
 <ALL RSL SIGNALS, SCK, CMD, DIFF CLOCK PAIRS MUST HAVE MATCHED ELECTRICAL LENGTH>

< CHANNEL IMPEDANCE : 40 OHM>
 <TRACE THICKNESS : 1 OZ CU>
 <LENGTH OF LOADED SEGMENT : 748 MILS>
 <TRACE WIDTH FOR UNLOADED SECTION : 10.4 MILS -> DEPENDENT ON VENDOR>
 <MINIMUM UNLOADED PITCH : 30 MILS>
 <FINISHED DIELECTRIC THICKNESS : 8 MILS -> DEPENDENT ON VENDOR)>

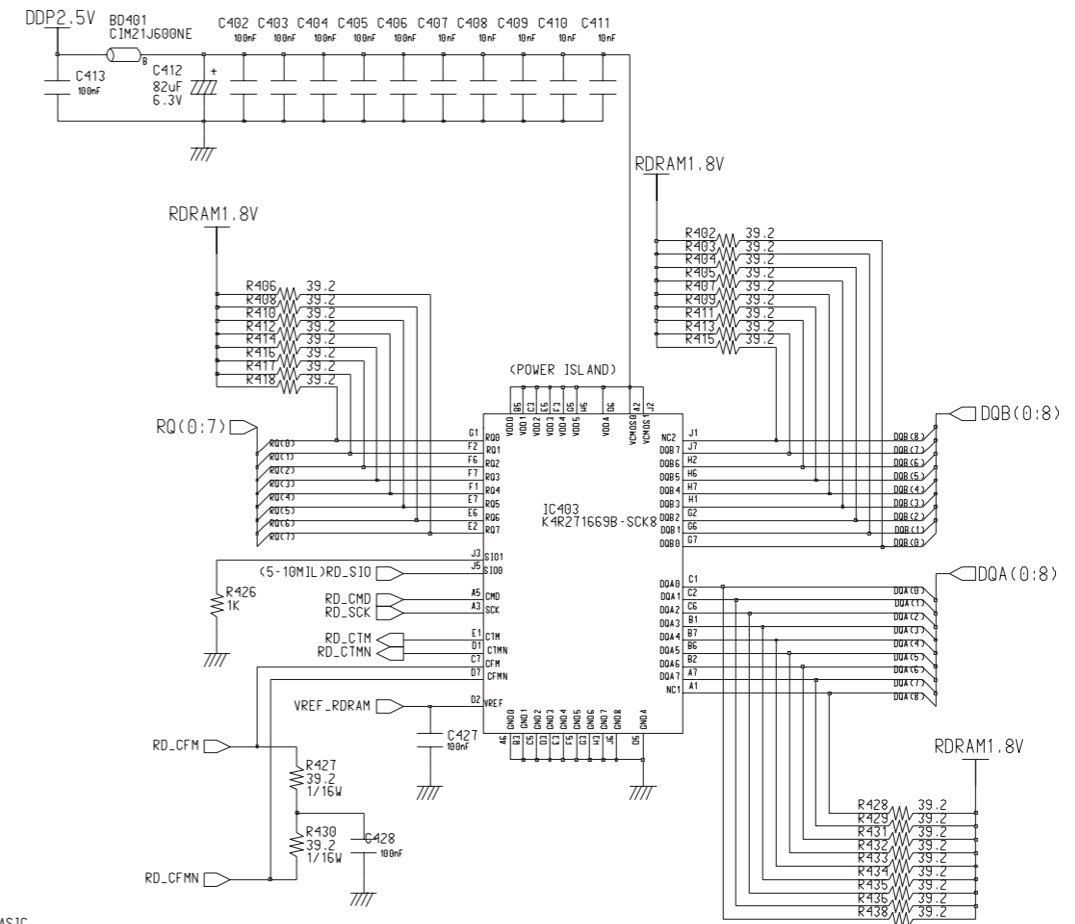

<RDRAM FOR SHORT CHANNEL, 54PIN>

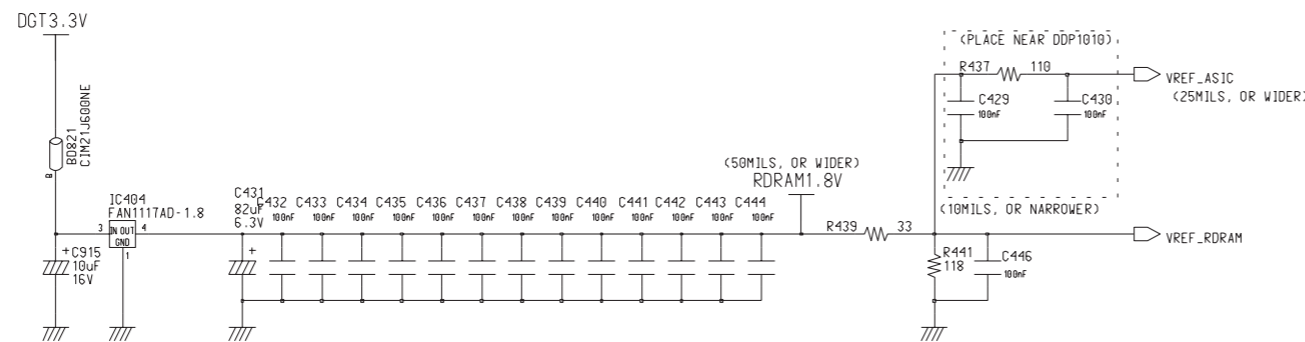

10-3-5 DMD Board-5

This Document can not be used without Samsung's authorization.

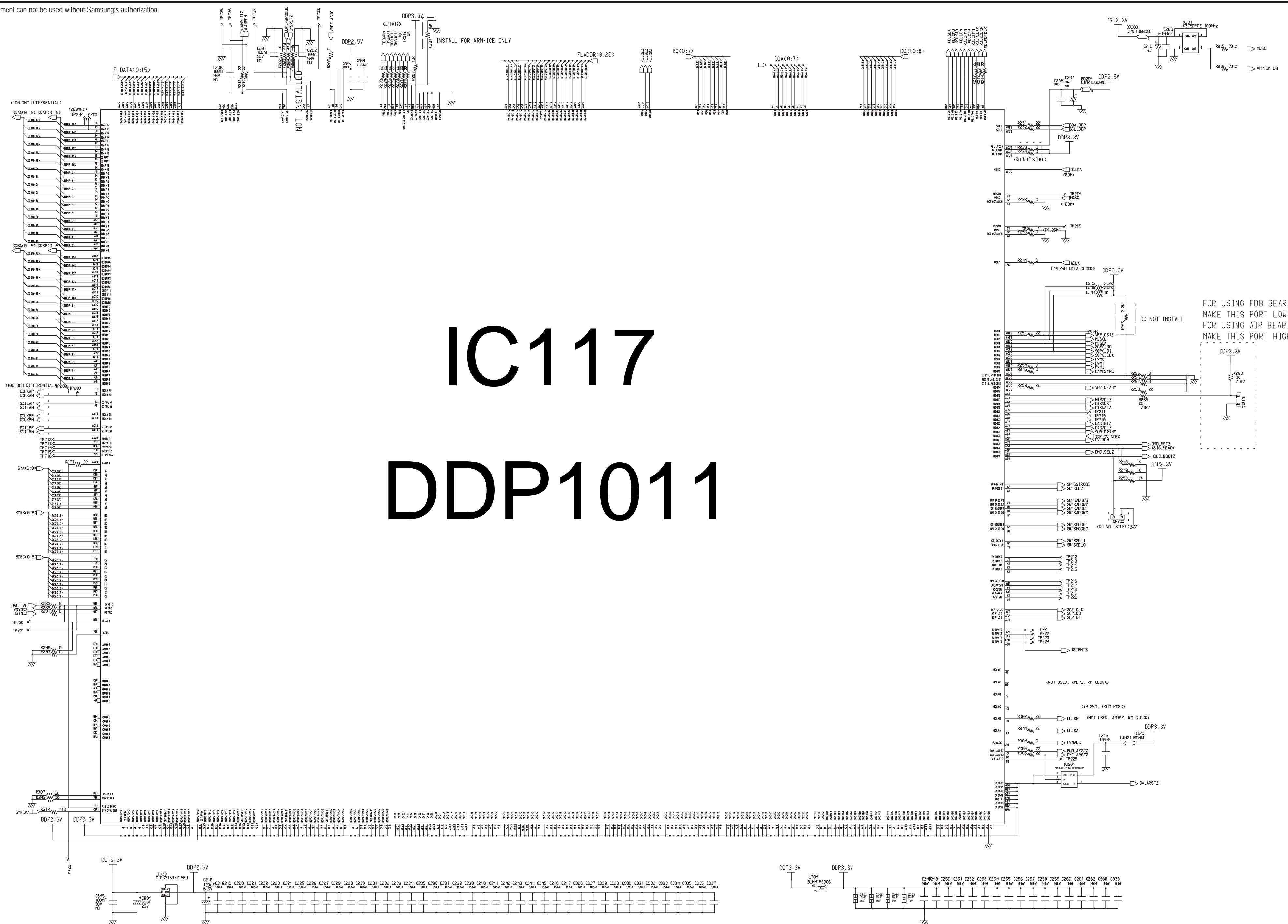

IC117

DDP1011

10-3-6 DMD Board-6

This Document can not be used without Samsung's authorization.

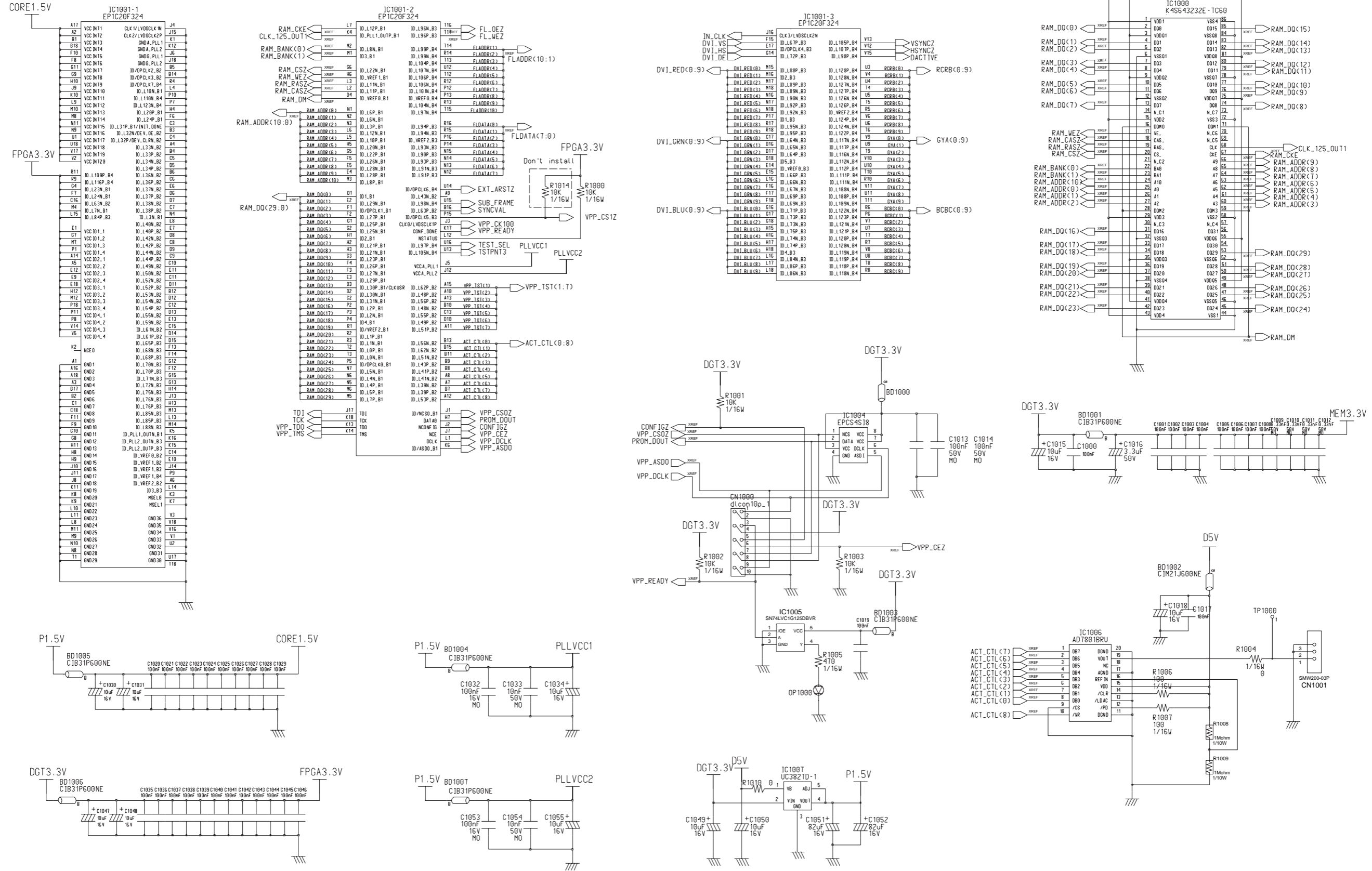

10-3-7 DMD Board-7

This Document can not be used without Samsung's authorization.

(COLOR WHEEL SENSOR DETECTION)

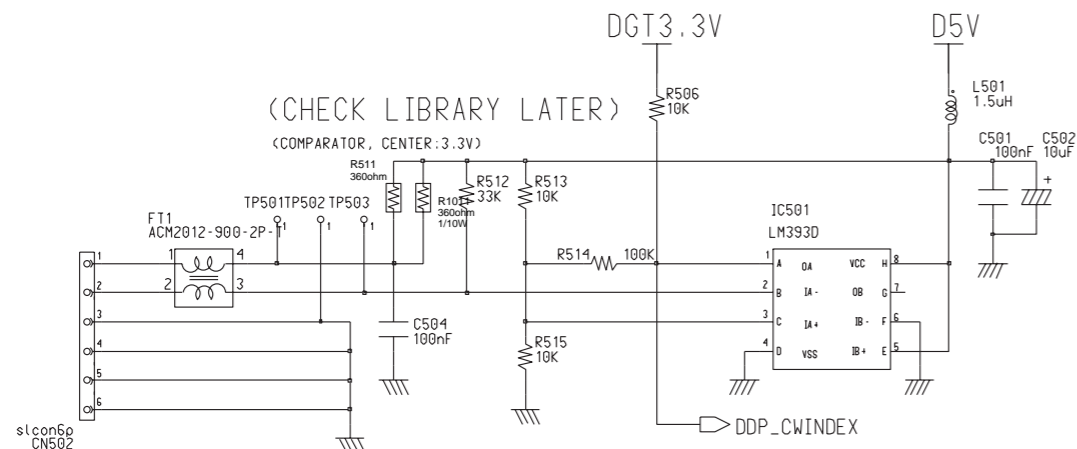

(LAMP CONTROL)

For Ballaster by Tho/Osr

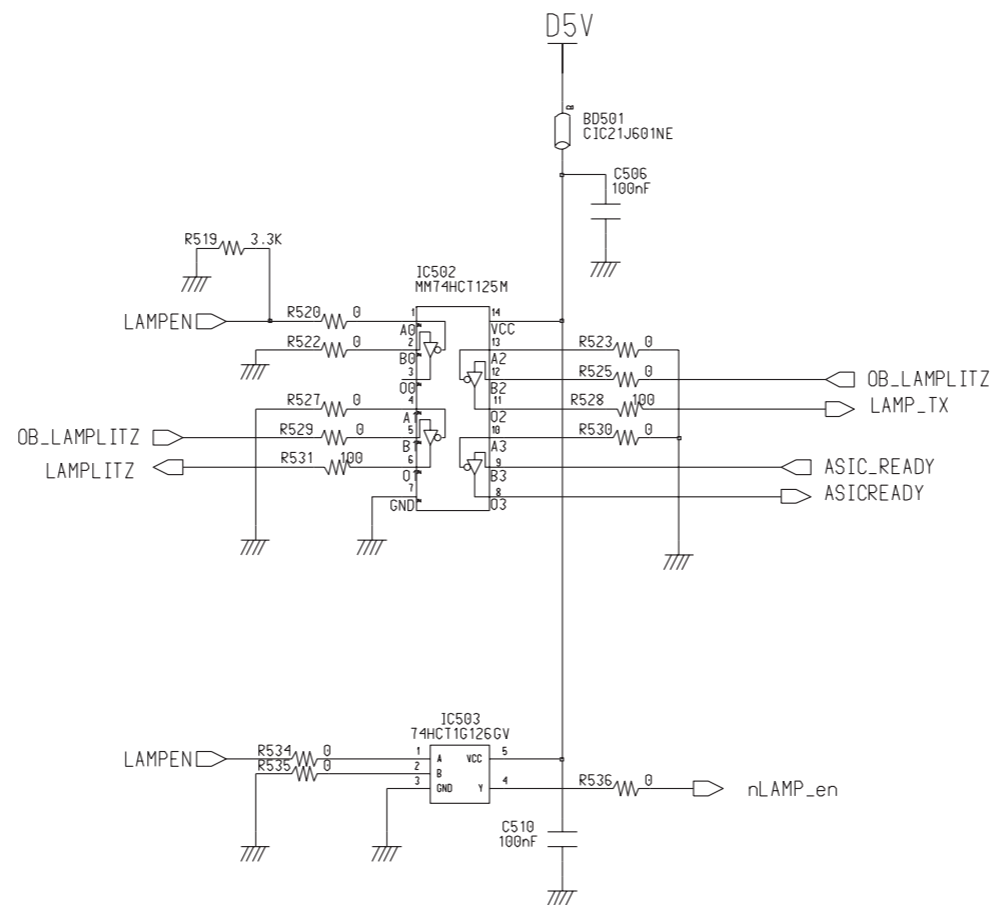

For Ballaster by Philips

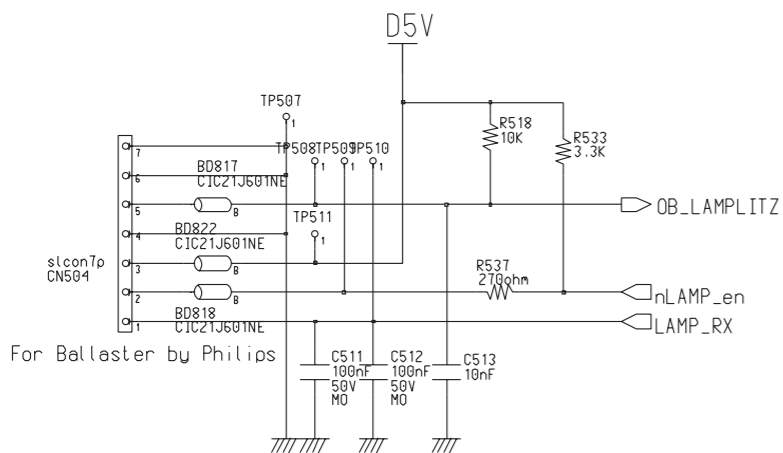

JTAG Configuration	R505	R830
Normal Operation	Not Installed	Installed
ARM-ICE Debug	Installed	Not Installed

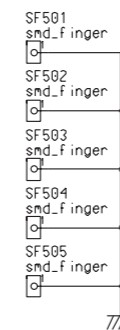
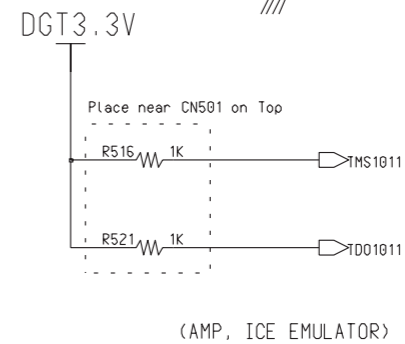
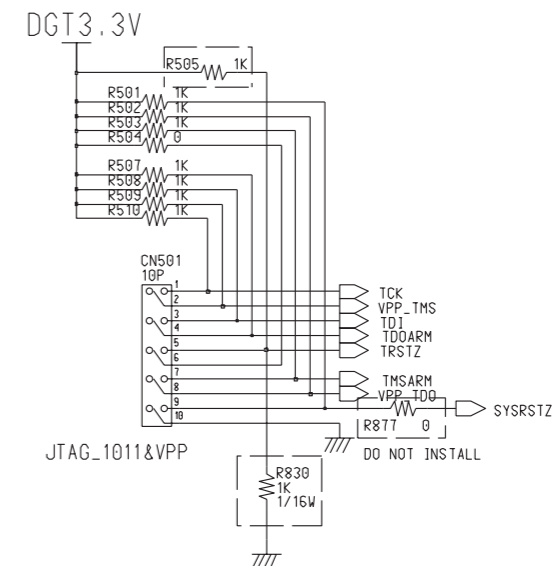

10-4 Actuator Board

This Document can not be used without Samsung's authorization.

(SIGNAL FROM ANALOG BOARD)

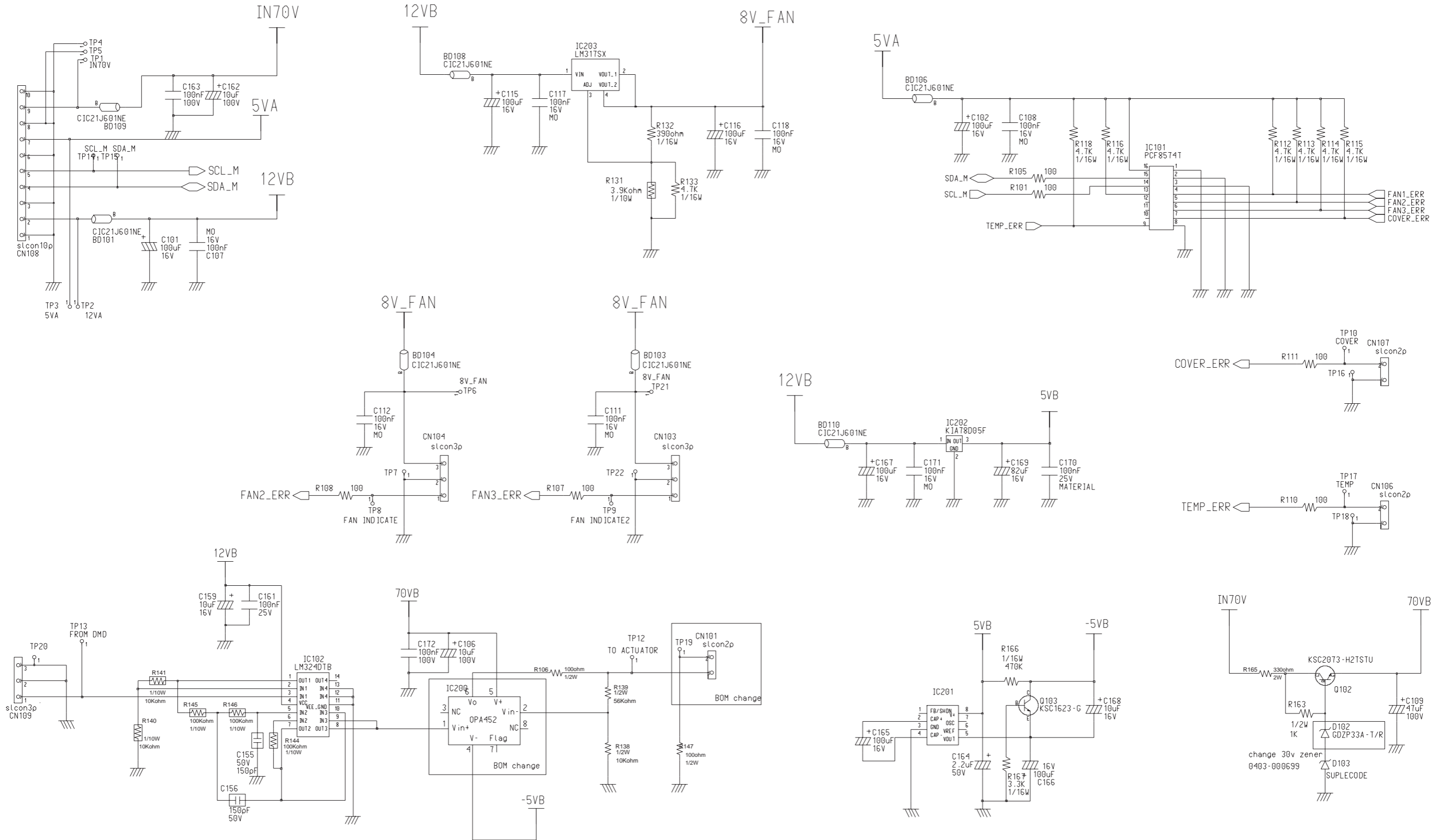

10-5 Ballast

This Document can not be used without Samsung's authorization.

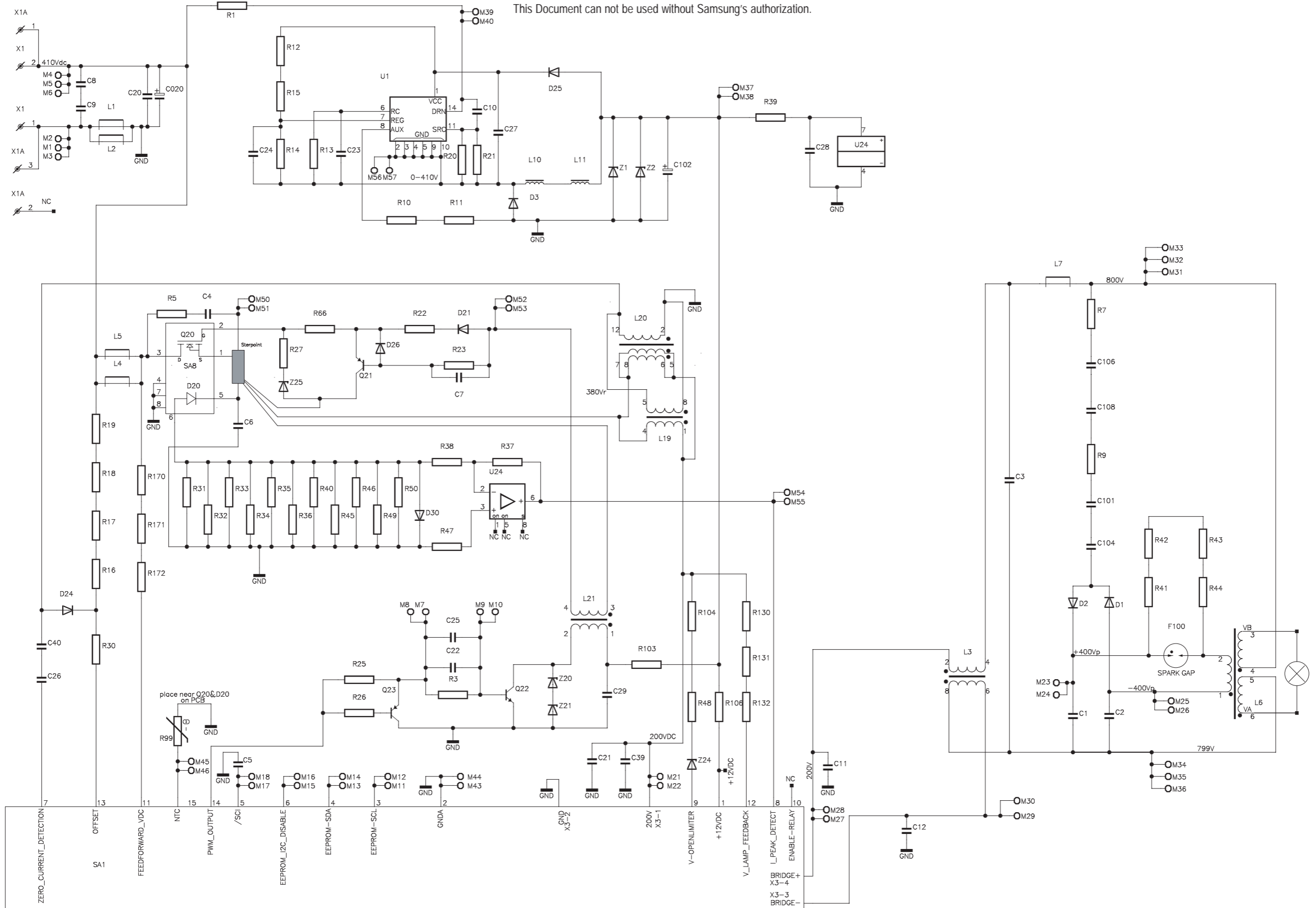

10-6 Power Board

This Document can not be used without Samsung's authorization.

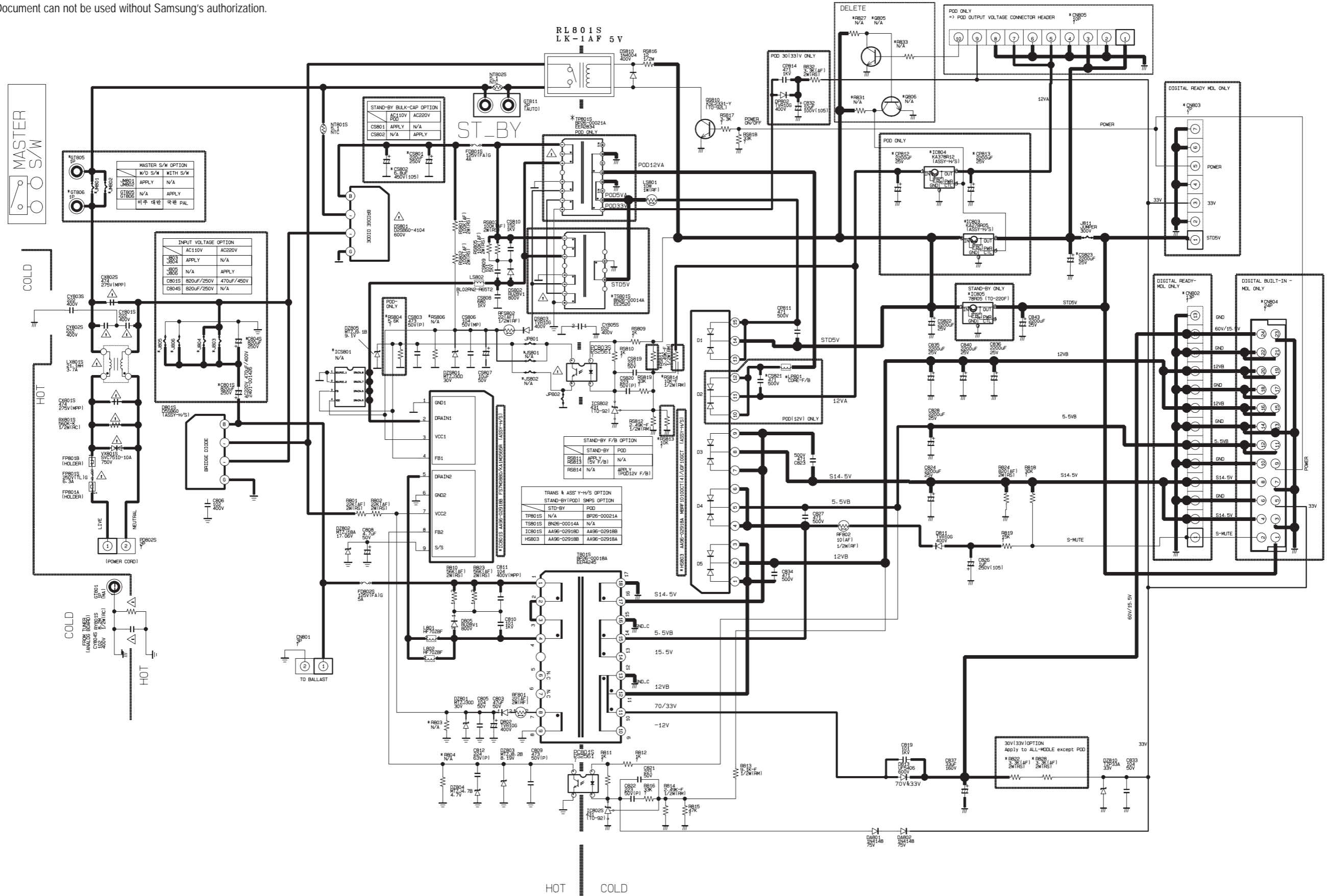

10-7 Combined Bridge and Control Module

This Document can not be used without Samsung's authorization.

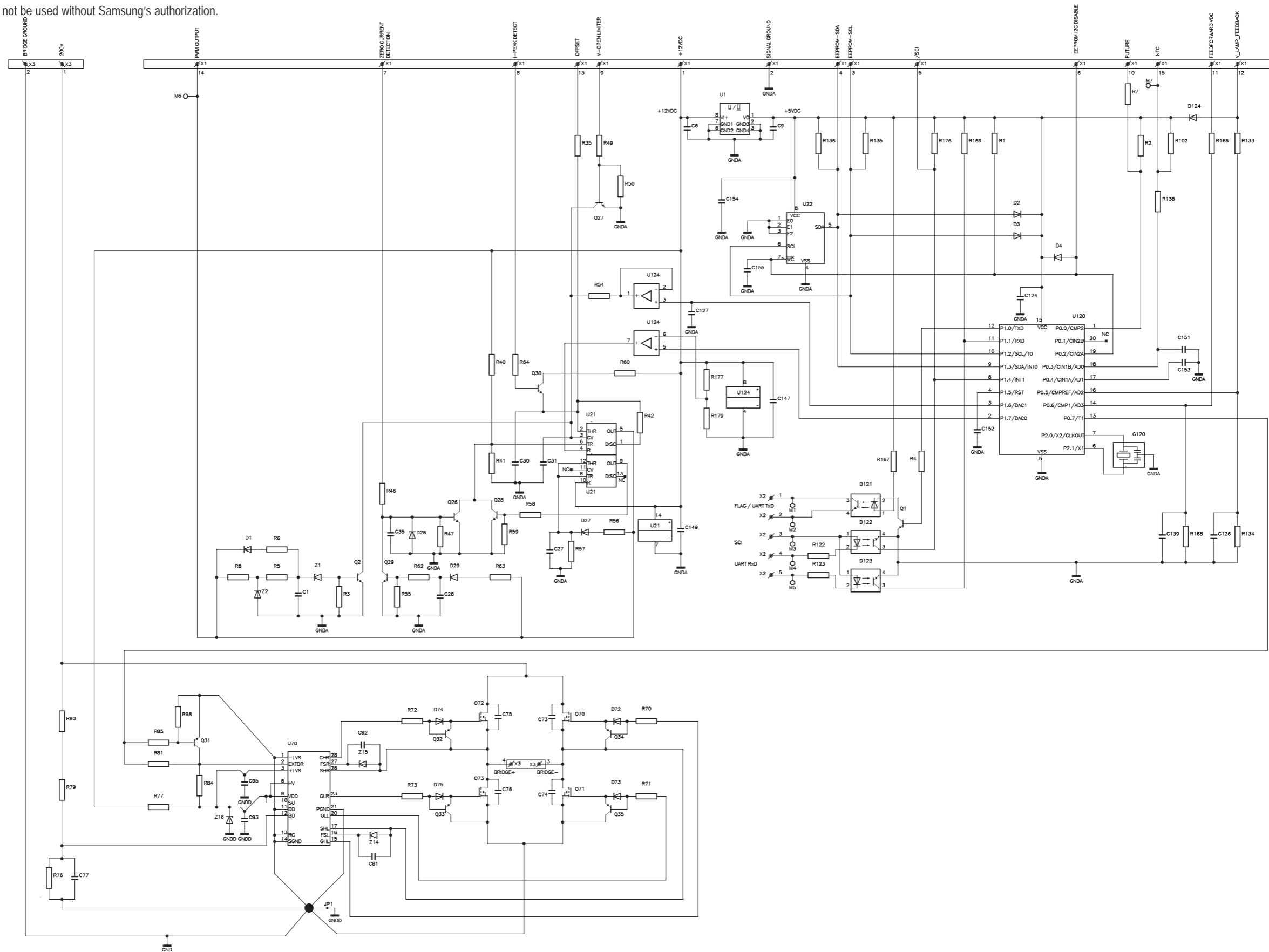

10-8 Detect

This Document can not be used without Samsung's authorization.

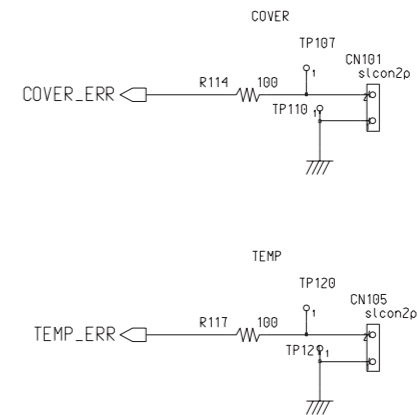
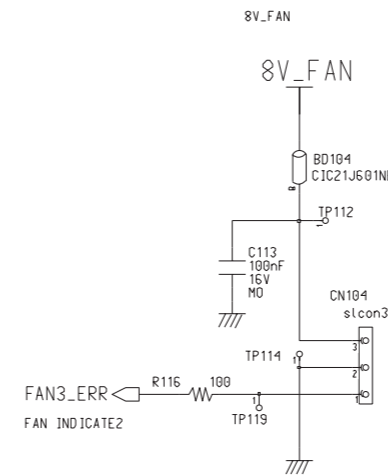
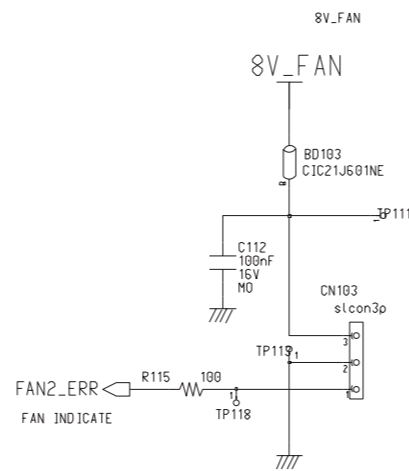
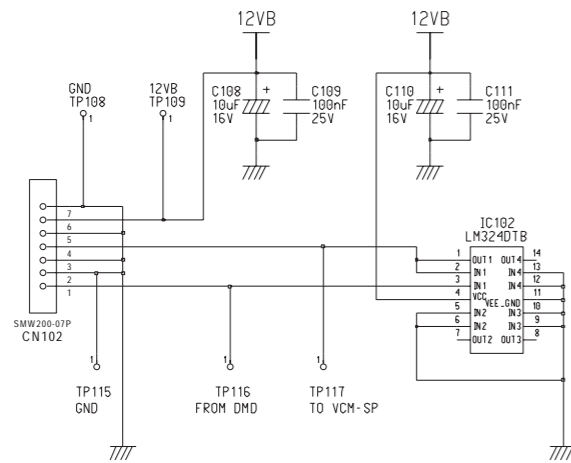
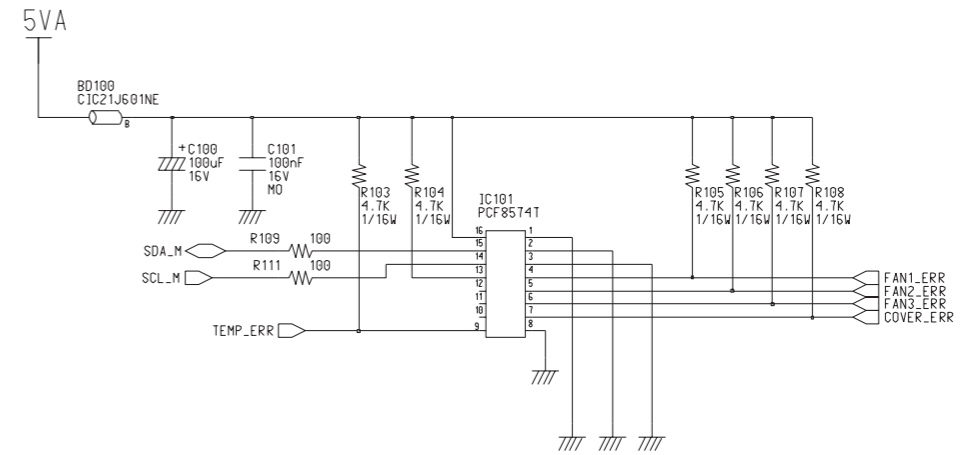
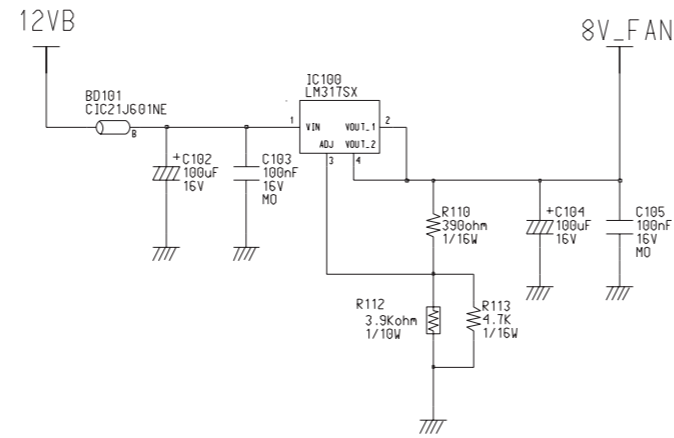
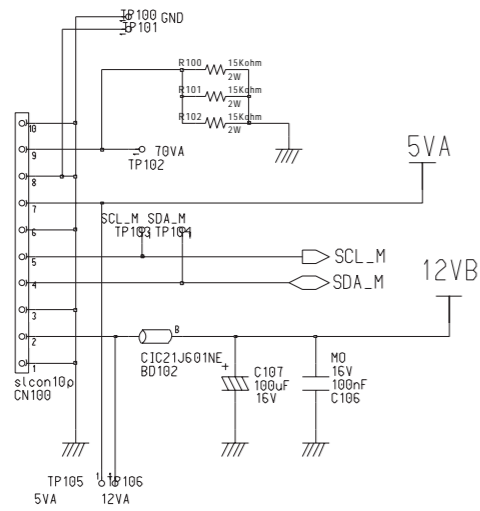

10-9 Side-AV

This Document can not be used without Samsung's authorization.

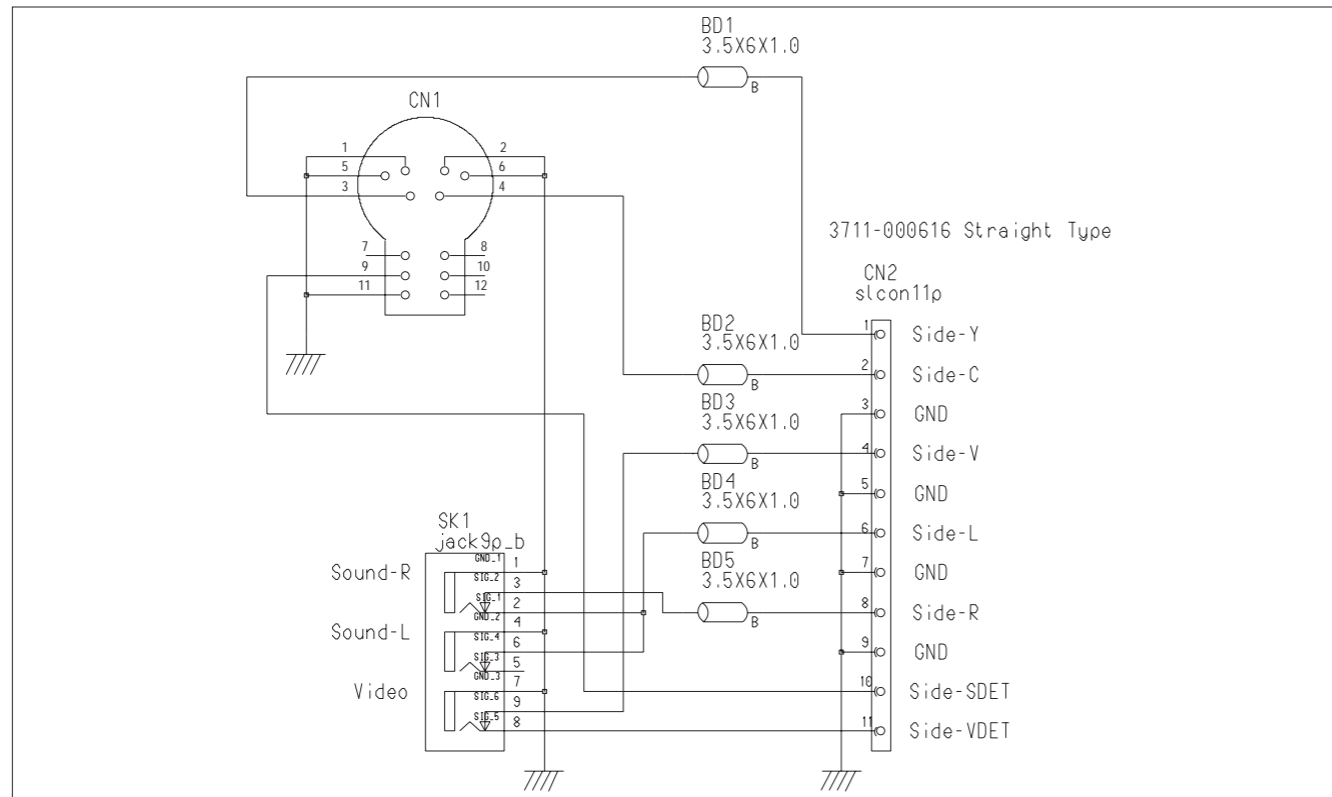

10-10 Key Control

This Document can not be used without Samsung's authorization.

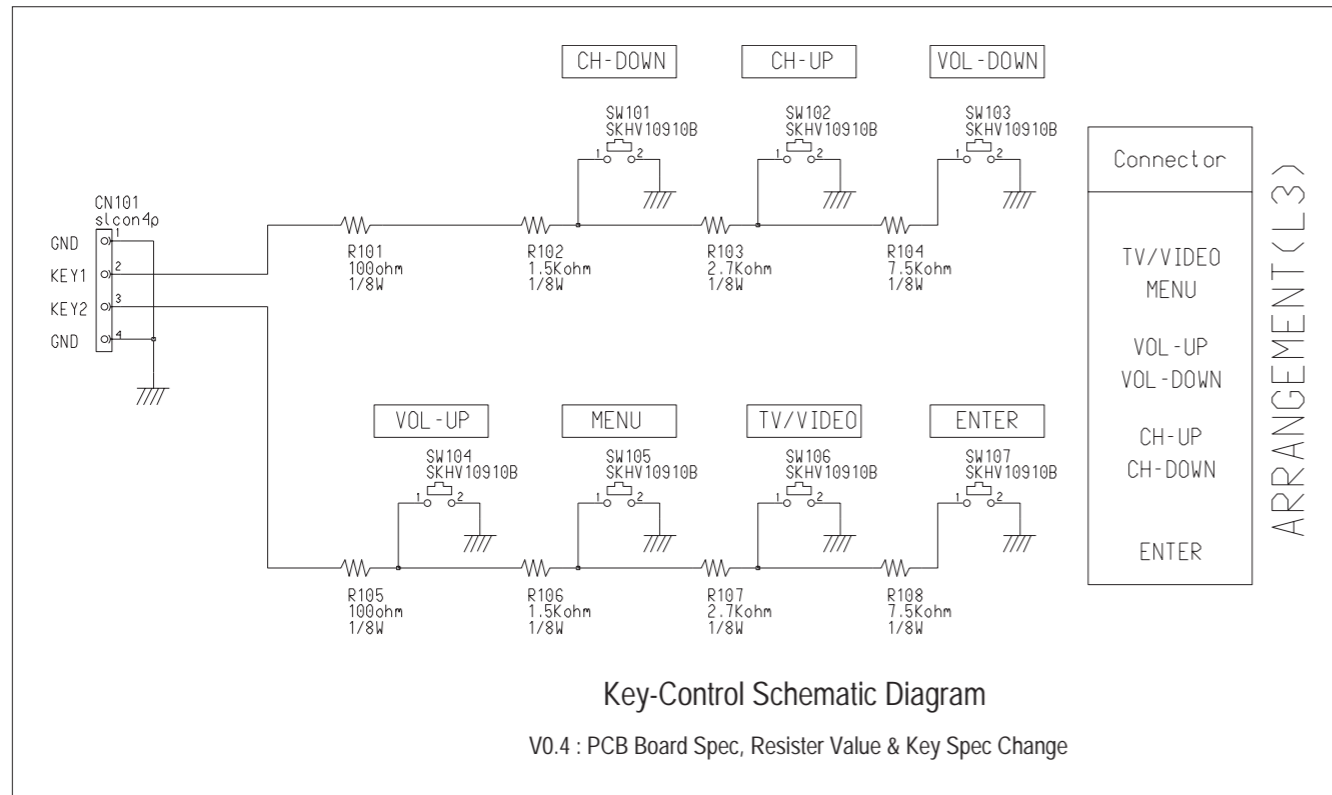

10-11 RMC-LED

This Document can not be used without Samsung's authorization.

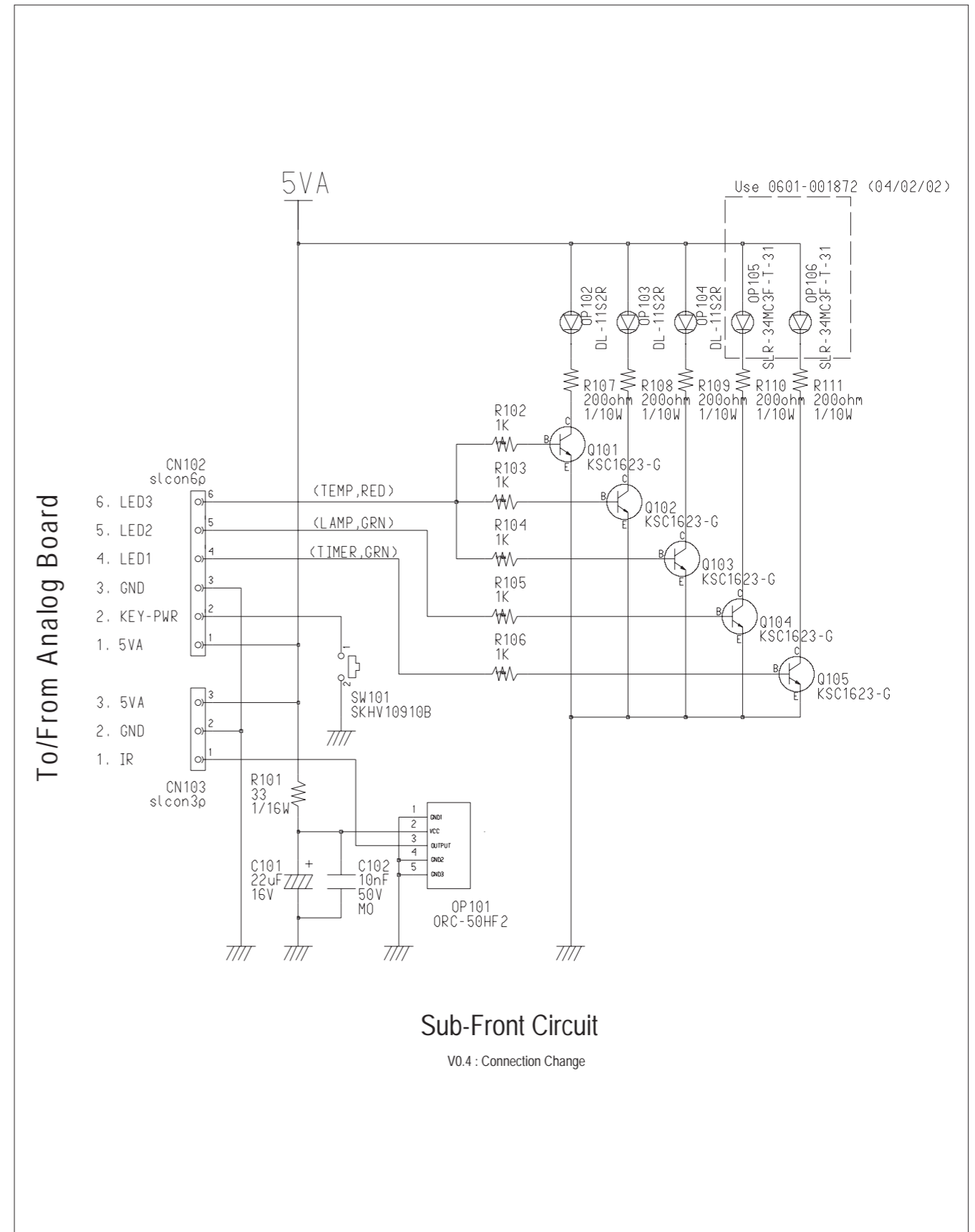

11. Operation Instruction & Installation

11-1 Product Features and Functions

11-1-1 Right side buttons

The buttons on the right side panel control your TV's basic features, including the on-screen menu system. To use the more advanced features, you must use the remote control.

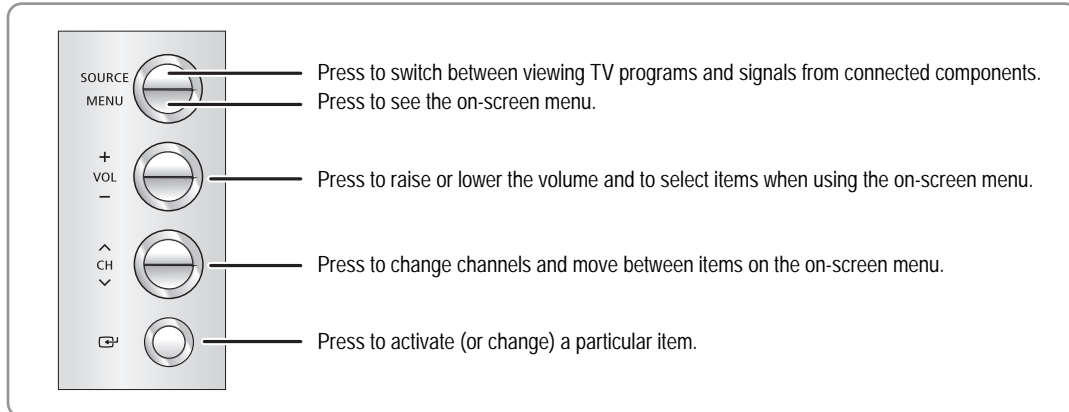

11-1-2 Side Panel Jacks

Use the right side panel jacks to connect a component that is used only occasionally (a camcorder or video game, for example).

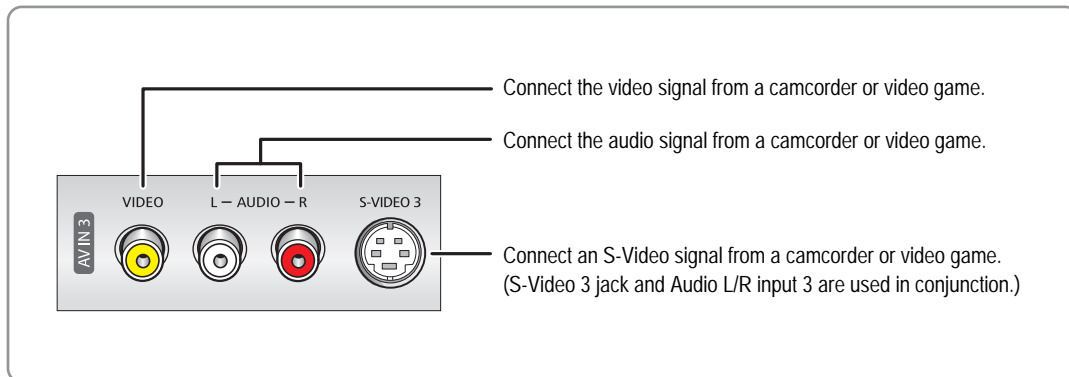

11-1-3 Front Panel LED Indicators

The three lights on the front panel indicate the status of your TV.

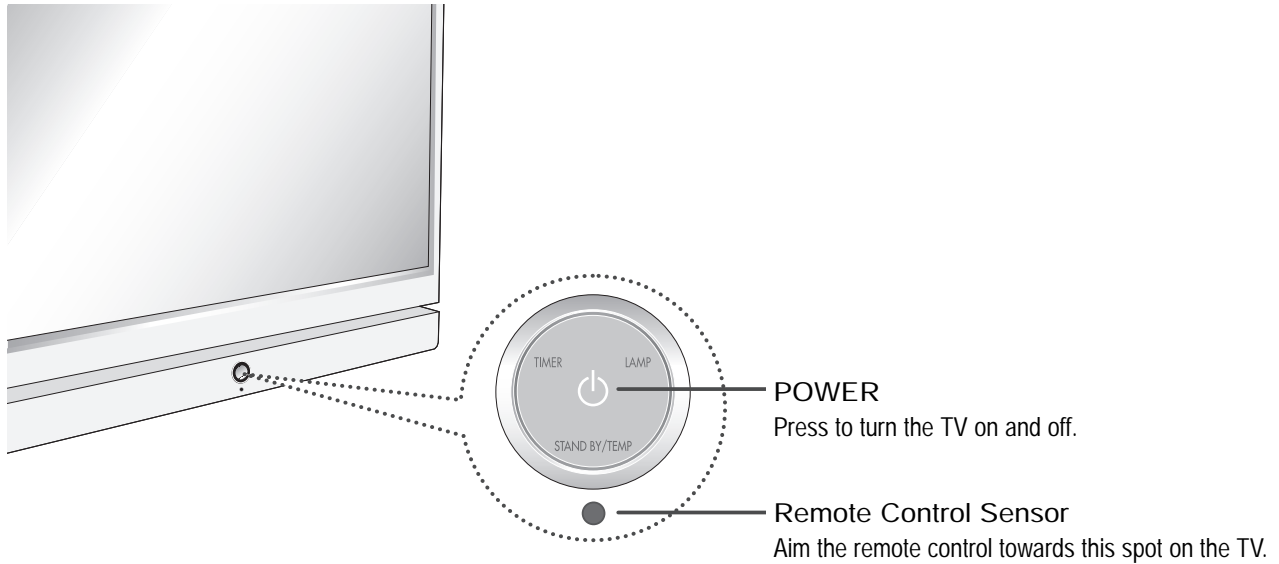

Indicator Light Key

- : Light is On
- ◐ : Light is Blinking
- : Light is Off

TIMER	LAMP	STAND BY/TEMP	Indication
○	○	●	Standby state.
○	◐	○	The picture will automatically appear in about 15 seconds.
●	◐	○	Auto Timer ON/OFF has been set and the set will automatically be turned on in about 25 seconds.
◐	○	◐	A cooling fan inside the set is not operating normally.
○	◐	◐	Lamp cover on the rear of the set is not properly shut.
○	○	◐	Check if the ventilation hole on the rear of the set is blocked, because if the inner temperature is too high, the power will shut off.
◐	◐	◐	Lamp may be defective.

- It takes about 30 seconds for the TV to warm up, so normal brightness may not appear immediately.
- The TV has a fan to keep the inside lamp from overheating. You'll occasionally hear it working.

11-1-4 Rear Panel Jacks

Use the rear panel jacks to connect components such as a VCR. You can connect different components such as VCRs, Set-Top Box and a DVD player etc., because there are two sets of video input jacks and two sets of component video input jacks on the rear panel of your TV. For more information, see "Connections".

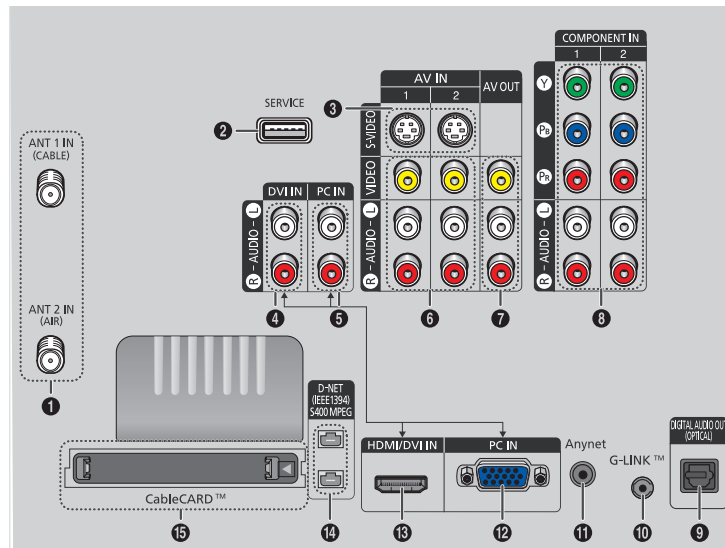

- ① **ANTENNA terminals**
Two independent cables or antennas can be connected to these terminals. Use "ANT1 IN (CABLE)" and "ANT2 IN (AIR)" terminals to receive a signal from VHF/UHF antennas or your cable system.
- ② **SERVICE**
This jack is for software upgrades..
- ③ **S-VIDEO INPUT jacks**
Connects an S-Video signal from an S-VHS VCR or DVD player.
- ④ **DVI (Digital Video Interface) AUDIO INPUT jacks**
Connect to the digital audio output jacks of a device with DVI output.
- ⑤ **PC AUDIO INPUT jacks**
Connect these to the audio output jacks on your PC.
- ⑥ **VIDEO/AUDIO INPUT jacks**
Connect video/audio signals from external sources, such as VCR or DVD players.
- ⑦ **VIDEO/AUDIO OUTPUT jacks**
Sends video/audio signals from the TV to an external source, such as a VCR. These jacks are available only in RF, Video and S-Video modes.
- ⑧ **COMPONENT1, 2 jacks (Y, PB, PR, L, R)**
Use these jacks to connect the component video/audio signals from a DVD player or a Set-Top Box.
- ⑨ **DIGITAL AUDIO OUT(OPTICAL) jack**
Connect to a Digital Audio Component.
- ⑩ **G-LINK™**
Connect the IR controller cable to the G-LINK™ terminal on your TV.
- ⑪ **Anynet**
Please refer to the Anynet Owner's Instruction.
- ⑫ **PC VIDEO INPUT jack**
Connect these to the video output jack on your PC.
- ⑬ **HDMI (High Definition Multimedia Interface)/ DVI INPUT jack**
Connect to the HDMI jack of a device with HDMI output. These inputs can also be used as a DVI connection with separate analog audio inputs. An optional HDMI/DVI cable will be necessary to make this connection. When using the optional HDMI/DVI adapter, the DVI analog audio inputs on your TV allow you to receive left and right audio from your DVI device.
- ⑭ **D-NET (IEEE1394) S400 MPEG**
Connect to external IEEE1394 digital products. Two jacks are provided for this purpose, which allow for a high degree of flexibility for connecting your D-Net controlled system.
- ⑮ **CableCARD™**
Insert the CableCARD into the slot.

11-1-5 Remote Control

You can use the remote control up to about 23 feet from the TV. When using the remote control, always point it directly at the TV. You can also use your remote control to operate your VCR, Cable box, DVD player or Samsung Set-Top Box.

- | | |
|--|---|
| <p>1. POWER
Turns the TV on and off.</p> <p>2. TV Guide
Press to display the TV Guide On Screen™ Interactive Program Guide (IPG). (Refer to TV Guide On Screen™ manual.)</p> <p>3. ANTENNA
Press to select "AIR" or "CABLE".</p> <p>4. CHANNEL NUMBER
Press to directly tune to a particular channel.</p> <p>5. -
Press to select additional channels (digital and analog) being broadcast by the same station. For example, to select channel "54-3", press "54", then press "-" and "3".</p> <p>6. VOL +, VOL -
Press to increase or decrease the volume.</p> <p>7. MUTE
Press to mute the TV sound.</p> <p>8. Anynet
Runs the Anynet view functions and sets up Anynet devices.</p> <p>9. MENU
Displays the main on-screen menu.</p> <p>10. CH.LIST
Displays the channel list.</p> <p>11. FAV.CH (Favorite Channel)
Press to switch between your favorite channels.</p> <p>12. MODE
Selects a target device to be controlled by the Samsung remote control (i.e., TV, STB, VCR, CABLE, or DVD).</p> <p>13. PRE-CH
Tunes to the previous channel.</p> <p>14. SOURCE
Press to display all of the available video sources (i.e., TV, Set-Top Box, VCR, DVD, DTV, PC).</p> <p>15. CH/PAGE ^ / ∨
Press to change channels. Moves from one set of screen information to the next in the TV Guide On Screen™.</p> <p>16. INFO
Press to display information on the TV screen.</p> | <p>17. EXIT
Press to exit the menu.</p> <p>18. ▲, ▼, ◀, ▶, ENTER
Press to select highlight up, down, left, or right. While using the on-screen menus, press the ENTER to activate (or change) a particular item.</p> <p>19. D-Net
Runs the D-Net view function.</p> <p>20. PIP (Picture In Picture)
Displays the available channels in sequence. (These buttons change channels in the PIP window only.)
PIP : When in the TV Guide On Screen, toggles the state between locked and unlocked in the Video Window.</p> <p>21. STILL
Press to pause the current screen.</p> <p>22. P.SIZE
Press to change the screen size.</p> <p>23. REC
Records a program in the TV Guide On Screen™.</p> <p>24. DNle (Digital Natural Image engine)
Activates DNle Demo mode.</p> <p>25. SET
Used during set up of this remote control, so that it will work compatibly with other devices (Set-Top box, VCR, Cable box, DVD, etc.)</p> <p>26. MTS (Multichannel Television Stereo)
Press to choose Stereo, Mono or SAP (Secondary Audio Program).</p> <p>27. PIP Controls CH ^ / ∨
Press to displays the available channels in sequence. (These buttons change channels in the PIP window only.)</p> <p>28. CAPTION
Controls the caption decoder.</p> <p>29. VCR/DVD Controls
Controls VCR or DVD functions: Rewind, Stop, Play/Pause, Fast Forward.
(◀◀/Day-, Day+ / ▶▶): Moves forward or backwards in 24 hour increments in the Listings Grid in TV Guide menu.)</p> <p>30. RESET
If your remote control is not functioning properly, take out the batteries and press the reset button for about 2-3 seconds. Re-insert the batteries and try using the remote control again.</p> |
|--|---|

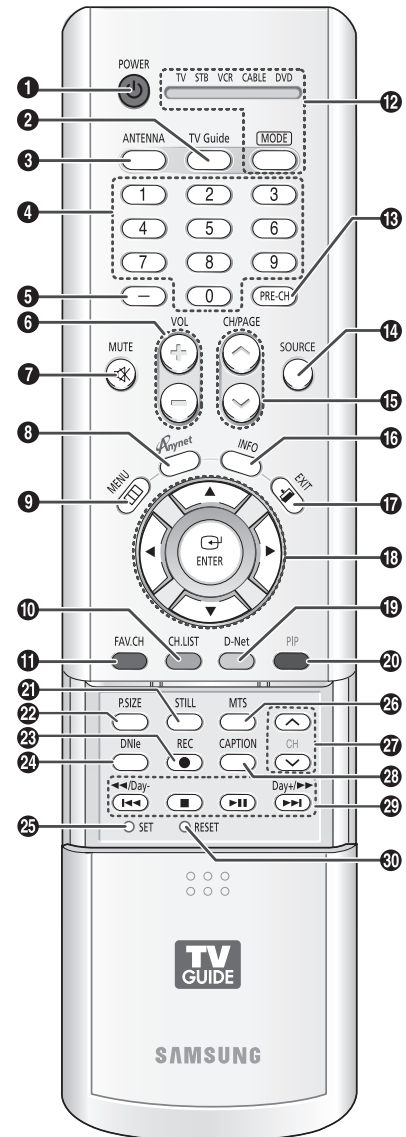

11-2 New Features

11-2-1 D-Net(IEEE1394)

D-Net(IEEE1394) is a cross-platform implementation of the high-speed serial data bus -- defined by the IEEE 1394-1995, IEEE 1394a-2000, and IEEE 1394b standards -- that can move large amounts of data between computers and peripheral devices. It features simplified cabling, hot swapping, and transfer speeds of up to 3.2 gigabits per second (on machines that support 1394b).

Major manufacturers of multimedia devices have been adopting the D-Net(IEEE1394) technology.

D-Net(IEEE1394) speeds up the movement of multimedia data and large files and enables easy connection of digital consumer products -- including, digital video tapes, digital video disks, set-top boxes, and music systems -- directly to a personal computer.

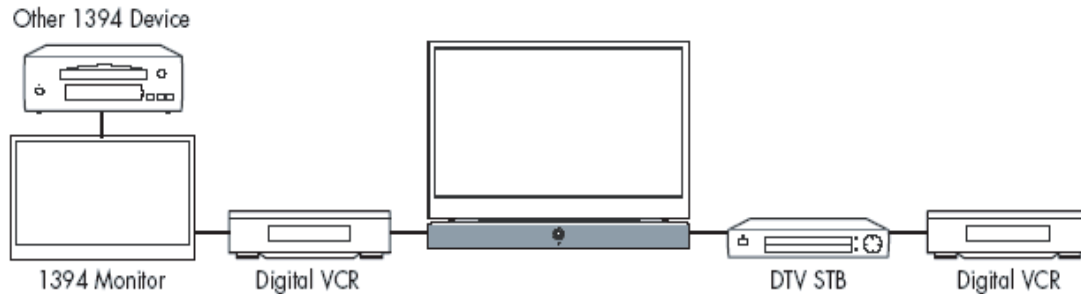

■ Key Features

- Real Time Audio/Video Transmission(MPEG-2, ...)
- High speed Data Transmission
 - 1394 upto 400Mbps
 - 1394.b upto 3.2 Gbps
- Hot Plug & Play
- AVC, CMP, EIA775, CEA931, 5C, ...
- Variety of Compatible devices :DTV, STB, DVHS, AVHDD, MPEG Camcorder, ...
- Copy protection

11-2-2 TV Guide On Screen

TV Guide On Screen is an interactive program guide that is built directly into consumer electronics products, including DLP, plasma and LCD televisions, personal video recorders and recordable DVD players.

The guide offers interactive on-screen program listings that enable viewers to quickly and easily navigate, sort, select, and schedule television programming for viewing and recording, all with simple remote control commands.

TV Guide On Screen's patented technology delivers continuously updated program listings to users, regardless of whether they receive their television signal via cable or over-the-air broadcast. TV Guide On Screen works by simply plugging in the television or recording device and activating the guide through an express set-up process.

The guide requires no subscription or special connection and is available at no cost to the consumer.



■ Key Features

- Listings Service:

Displays eight days of viewers' local program listings and descriptions for broadcast and cable;

Viewers can tune to any program, schedule a program to record, or set a reminder, with the press of a button;

The Video Window lets viewers monitor the last channel tuned while viewing program listings, or preview channels as they page through listings;

Color-coded program genres help viewers quickly identify movies, sports, and children's programming.

- Search Feature:

Viewers can search for programs by categories such as HDTV, movies, sports or children's shows. Within categories, viewers can sort by show type, such as baseball or football.

Viewers can sort alphabetically, or by a key word such as a show title or a starring actor.

- One-touch Recording:

To record, viewers simply highlight a program title and then press a button on the remote control. TV Guide On Screen will automatically record the program;

Programs may be set to record one time or every time they air;

TV Guide On Screen is a critical component of the recordable devices into which it is built. A week's worth of listings and powerful sorting and recording features make advanced recording simple

- Reminder Feature:

Viewers may set reminders to ensure they never miss their favorite shows;

Reminders can even be set to automatically turn on the TV when a show begins.



11-2-3 CableCARD

A small PCMCIA device, not working by itself, designed to run specialized tasks in association with a DCR TV, such as a conditional access sub system or to provide resources required by an application but not provided directly by the host.

12. Disassembly & Reassembly

12-1 Overhaul Disassembly & Reassembly

12-1-1 Separation of the back cover and the chassis

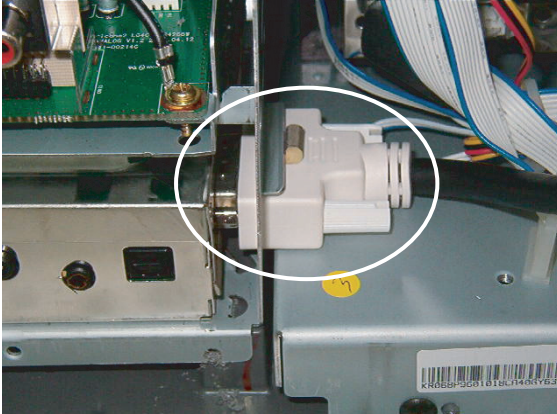
Part Name	Description	Description Photo
Back Cover	① Remove 12 screws to remove the back bottom cover. : TH,B,M4.L15,BLK,SWRCH18A	
Terminal Board	① Loosen and remove the 5 screws on the terminal board and jack. : TH,B,M4.L15,BLK,SWRCH18A	
Holder Chassis	① Separate the DVI cable. ⚠ : The DVI screw is made of soft plastic and may easily break when applying excessive force through a screw driver. Ensure that extreme caution is taken when loosening the screw.	

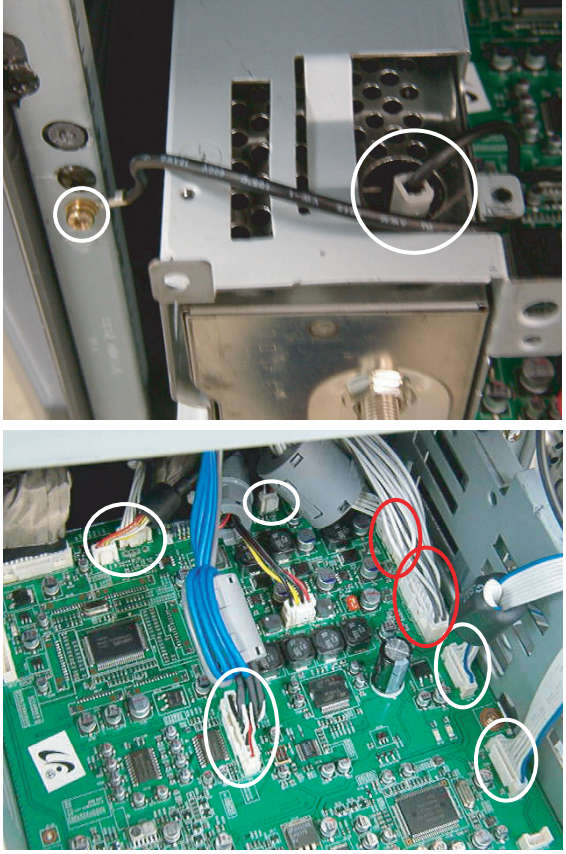
Part Name	Description	Description Photo
Holder Chassis	<ol style="list-style-type: none"> <li data-bbox="305 205 529 233">① Seperate the Gt-wires. <li data-bbox="305 262 513 289">② Seperate the cables. 	

12-1-2 Separation of the Analog and Digital Board

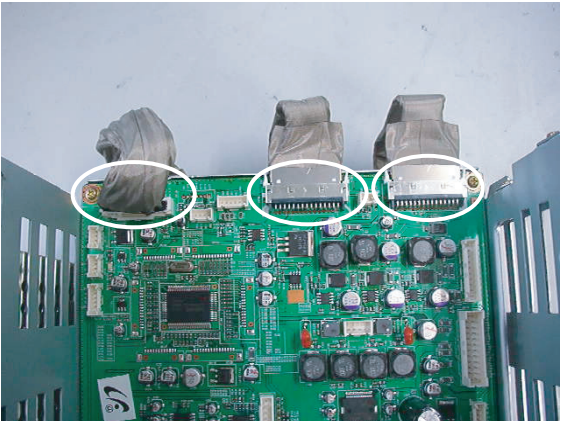
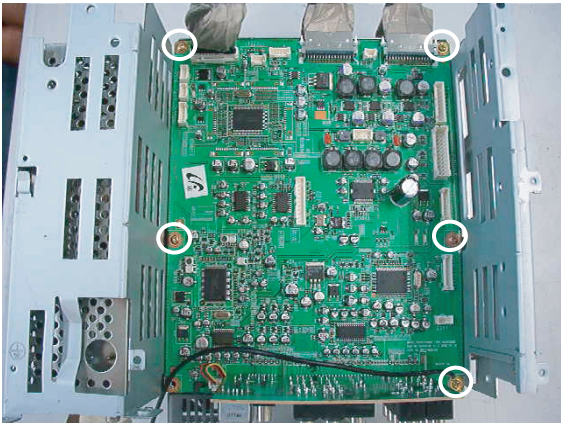
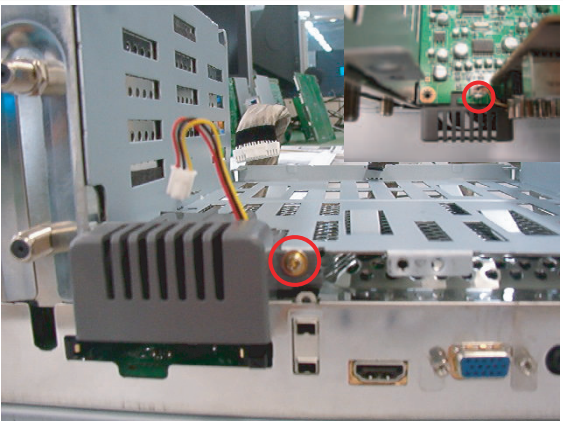
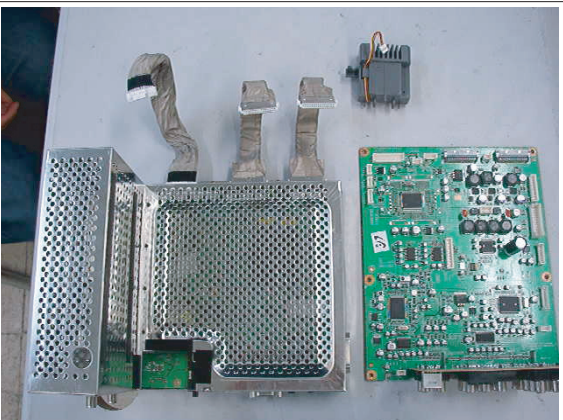
Part Name	Description	Description Photo
Analog Board	<p>① Separate the cables.</p> <p>⚠ : The 30 pin shield cable should be removed by holding the two lock ends of the cable, as failing to do so, could damage the connector.</p>	
	<p>① Remove the 5 screws : PWH,B,M3,L10,ZPC(YEL),SWRCH18A</p>	
Fan	<p>① Remove both the connector and the screws before removing the fan. Then remove the fan from the holder chassis. : PWH,B,M3,L10,ZPC(YEL),SWRCH18A</p>	
Analog Board/ Digital Board/ Fan	<p>① Analog, Digital Board and Fan.</p>	

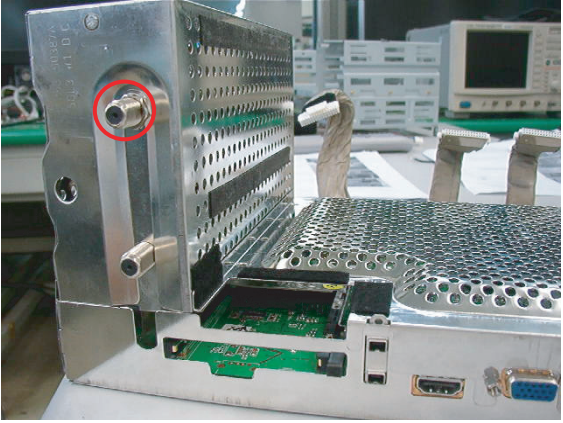
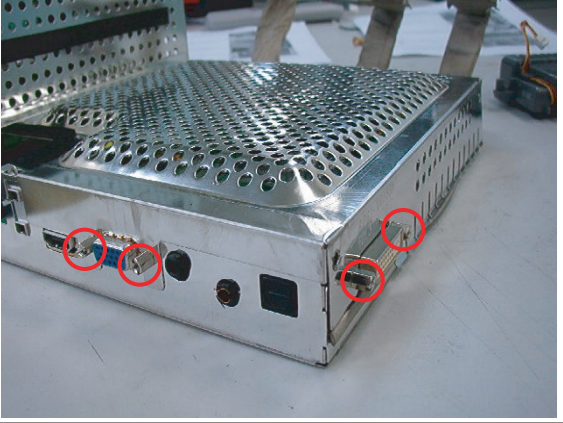
Part Name	Description	Description Photo
Digital Board	<p>① Use the long-nosed pliers to remove the hex nuts. Nut-Hexagon : -,M3/8X32,ZPC(WHT),MBSBD</p>	
	<p>① Remove the 4 standoffs. StandOff : M3,L5,Ni PLT,SUM24L,#4-40</p> <p>⚠ : The standoff may easily break through applying excessive force. Ensure that extreme caution is taken.</p>	
	<p>① Remove the 2 screws and 3 cables. : PWH,B,M3,L10,ZPC(YEL),SWRCH18A</p> <p>⚠ : The 30 pin shield cable should be removed by holding the two lock ends of the cable, as failing to do so, could damage the connector.</p>	
	<p>① After Removing the Top Shield Case.</p> <p>⚠ : Use the two lock holes on either side of the shield case when removing it.</p>	

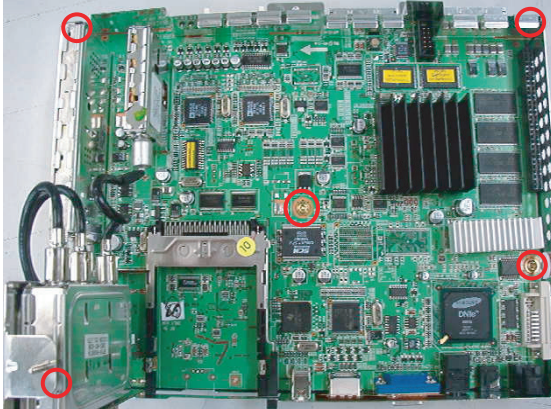
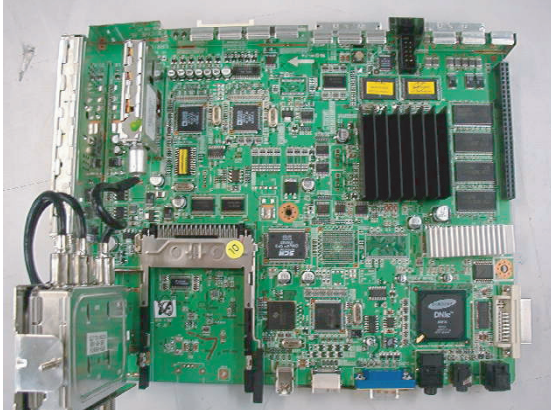
Part Name	Description	Description Photo
Digital Board	<p>① Remove the 5 screws before removing the shield case at the bottom. : PWH,B,M3,L10,ZPC(YEL),SWRCH18A</p>	 A top-down photograph of a green printed circuit board (PCB) populated with various electronic components. Five screws are highlighted with red circles: two at the top corners, one in the center, and two at the bottom corners. The board features a large black heat sink, several integrated circuits, and various connectors.
	<p>① Digital Board.</p>	 A bottom-up photograph of the same green PCB, showing the reverse side of the components. It displays various surface-mount components, connectors, and the underside of the heat sink.

12-1-3 Separation of the Optical Engine

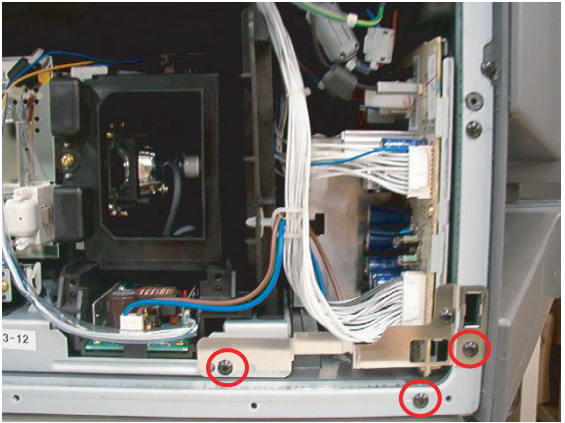
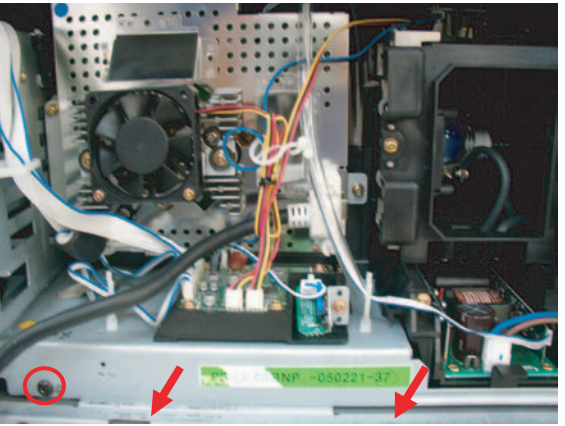
Part Name	Description	Description Photo
Optical Engine	<p>① Remove the 3 screws to remove the bracket. : TH,B,M4.L15,BLK,SWRCH18A</p>	
	<p>① Remove the screw and Remove the engine by pulling it out of the cabinet. : TH,B,M4.L15,BLK,SWRCH18A</p> <p>⚠ : Be careful when removing the Light Engine as it may get caught up by the upper cable of the case.</p>	

12-1-4 Separation of the Power Board

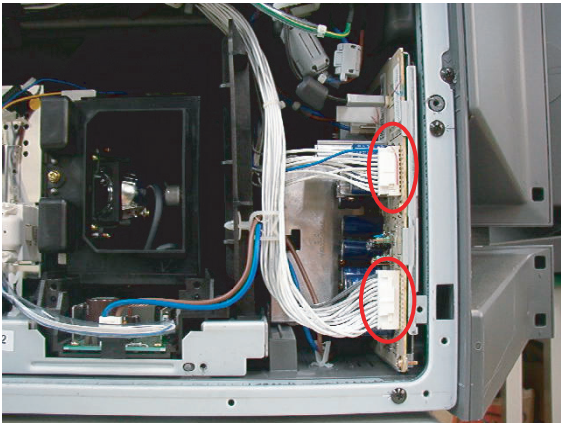
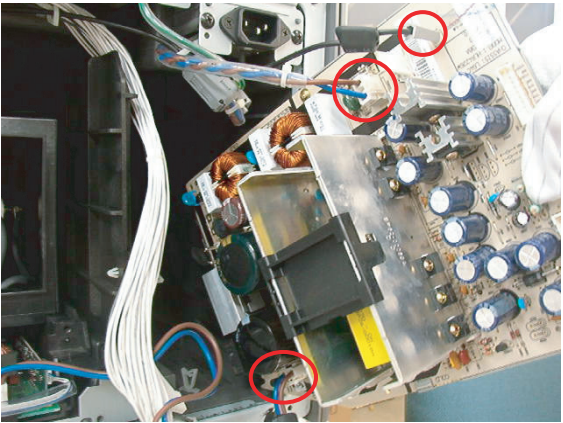
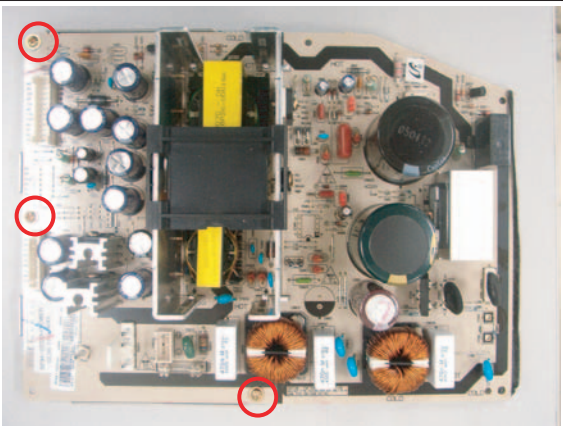
Part Name	Description	Description Photo
Power Board	① Separate the 2 cables.	
	① Remove the power board carefully before disconnecting the cables. ⚠ : Wear gloves when handling the power board as there may be some remaining electrical charge in the capacitors. Specifically, avoid touching any part of the capacitors.	
	① After removing the 3 screws, separate the bottom power bracket. : PWH,B,M3,L10,ZPC(YEL),SWRCH18A	

12-1-5 Lamp Replacement

⚠ Notice

1. Replace with the correct code numbered lamp to avoid damage to the TV.
2. Turn the power off and wait for 30 minutes before replacing the lamp as it will be hot.
3. Do not touch the glass part of the lamp with your bare hands nor insert any foreign object inside the cover as it may cause poor screen quality, electric shock or fire.
4. Do not place the old lamp near flammable objects or within the reach of children.
5. Be sure to connect this TV directly to an AC wall outlet. If the TV's AC plug is connected to a cable box or other source, it will not allow for proper cool down time.

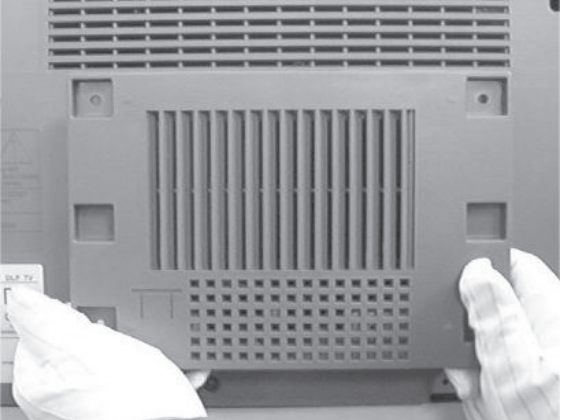
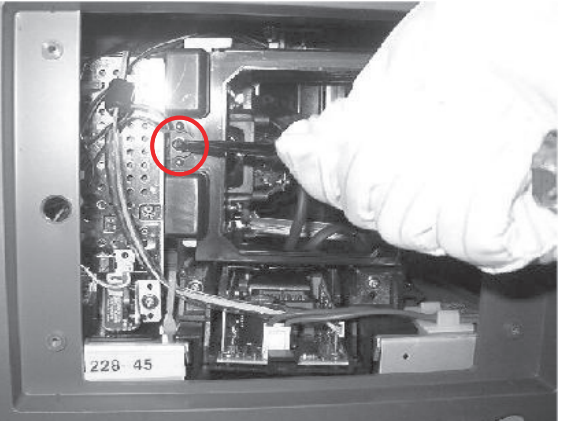

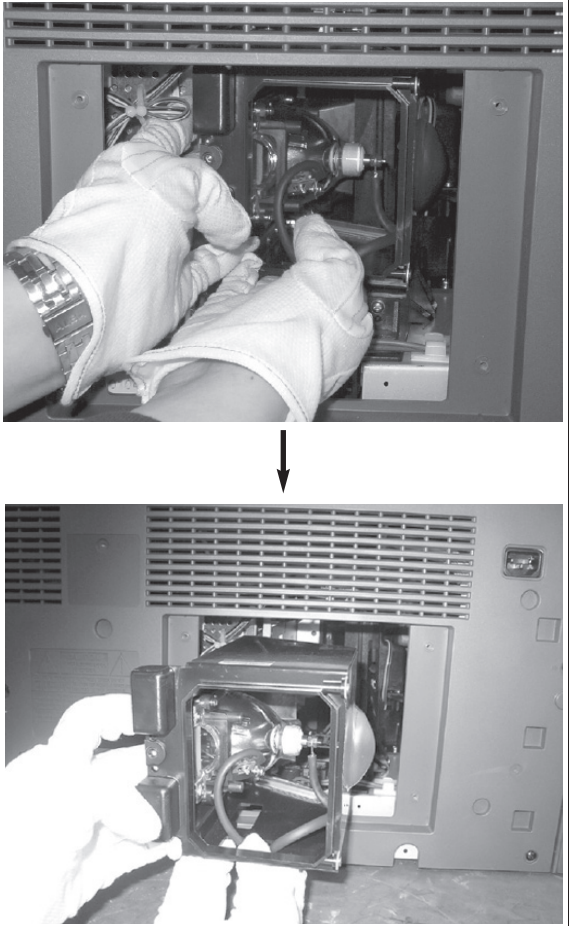
Part Name	Description	Description Photo
Lamp	① Unplug the TV, then use a screwdriver to remove the 4 screws. : WSP,PH,+,M4,L12,ZPC(YEL),SM10C	
	① Remove the Lamp cover.	
	① Remove the screw securing the Lamp by using a screwdriver. : WSP,PH,+,M4,L12,ZPC(YEL),SM10C	

Part Name	Description	Description Photo
Lamp	<p data-bbox="302 201 841 260">① Separate the Lamp from the engine by holding the handle and pulling it out.</p> <p data-bbox="302 289 834 319">② To reinstall the Lamp, follow these steps in reverse order.</p>	 <p>The 'Description Photo' column contains two sequential images. The top image shows a person's hands, wearing white gloves, pulling a rectangular lamp assembly out of the engine compartment of a device. The bottom image shows the lamp assembly being held out, with a black arrow pointing downwards between the two images, indicating the sequence of steps.</p>

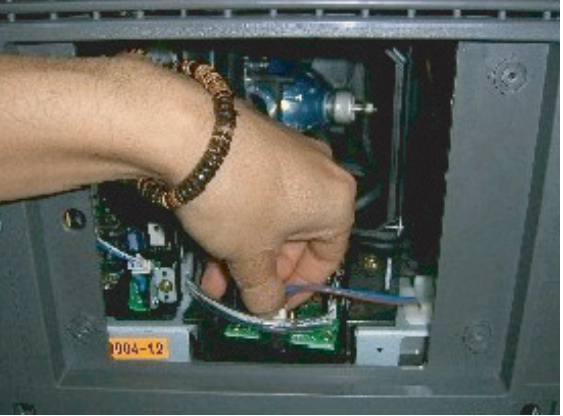
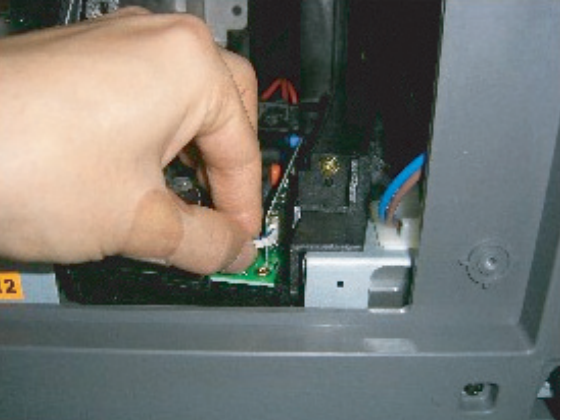
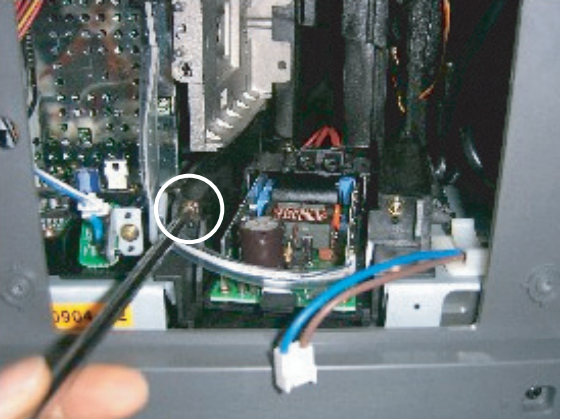
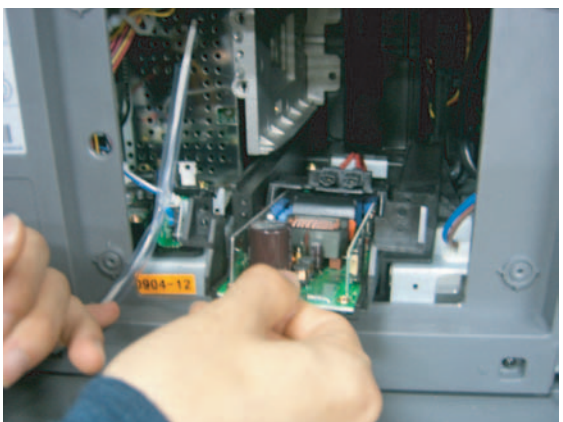
12-1-6 Ballast Replacement

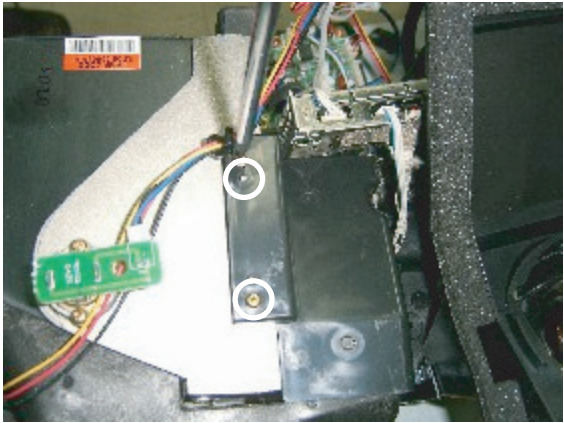
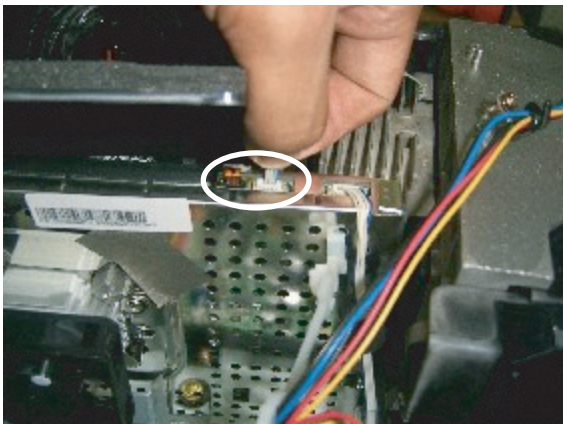

Part Name	Description	Description Photo
Ballast Board	① Remove the lamp, referring to lamp replacement.(12-8page) Remove the ballast power cable.	 A close-up photograph showing a person's hand, wearing a watch, pulling a blue and red power cable away from a green ballast board. The board is mounted inside a grey metal chassis. A yellow label with the number '1904-12' is visible on the board.
	① Remove the Ballast SCI cable.	 A close-up photograph showing a hand disconnecting a white SCI cable from a connector on the ballast board. The board is still inside the chassis. A yellow label with the number '2' is visible.
	① Remove the two screws at the Holder Ballast. : PWH,+ ,B,M3,L10,ZPC(YEL),SWRCH18A,-	 A close-up photograph showing a hand using a screwdriver to remove a screw from a metal ballast holder. A white circle highlights the screw being worked on. The ballast board is visible in the background. A yellow label with the number '1904' is visible.
	① Pull out the Ballast assembly. ② Replace it with a new one and re-assemble it in the reverse order.	 A close-up photograph showing a hand pulling the ballast board and its holder out of the grey metal chassis. The board is held by the holder. A yellow label with the number '1904-12' is visible.

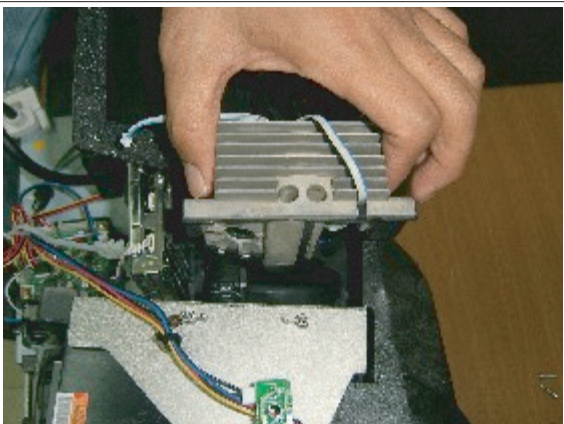
12-1-7 Color Wheel Ass'y Replacement

Part Name	Description	Description Photo
Color Wheel	① Remove 2 screws to remove the color wheel cover. (L620 doesn't have the cover color wheel.) : WSP,PH,+,M3,L8,ZPC(YEL),SW	
	① Remove two cables at the DMD Board.	
	① Remove 2 screws. : PWH,+,B,M3,L10,ZPC(YEL),SWRCH18A,-	
	① Disassemble the color wheel assembly.	

Part Name	Description	Description Photo
<p>Color Wheel</p>	<p>① Replace it with a new color wheel and rubber assembly.</p> <p>⚠ : Never touch the color wheel. Touch only the cover assembly.</p>	

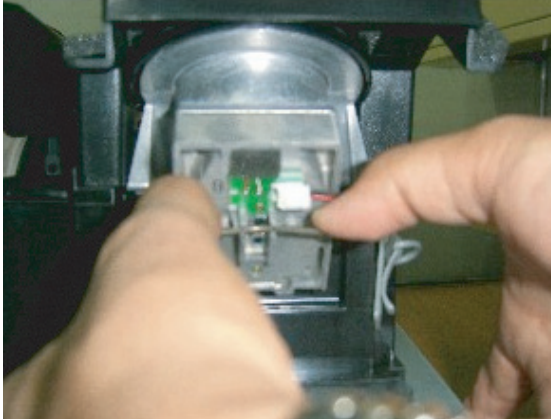
12-1-8 Actuator(Smooth Picture) Replacement

Part Name	Description	Description Photo
Actuator	① Remove the cable at the Actuator.	
	① Push the steel spring wire to bottom of the Actuator Assy.	
	① Replace it with a new actuator.	

MEMO

13. Circuit Description

13-1 Overall Block Description

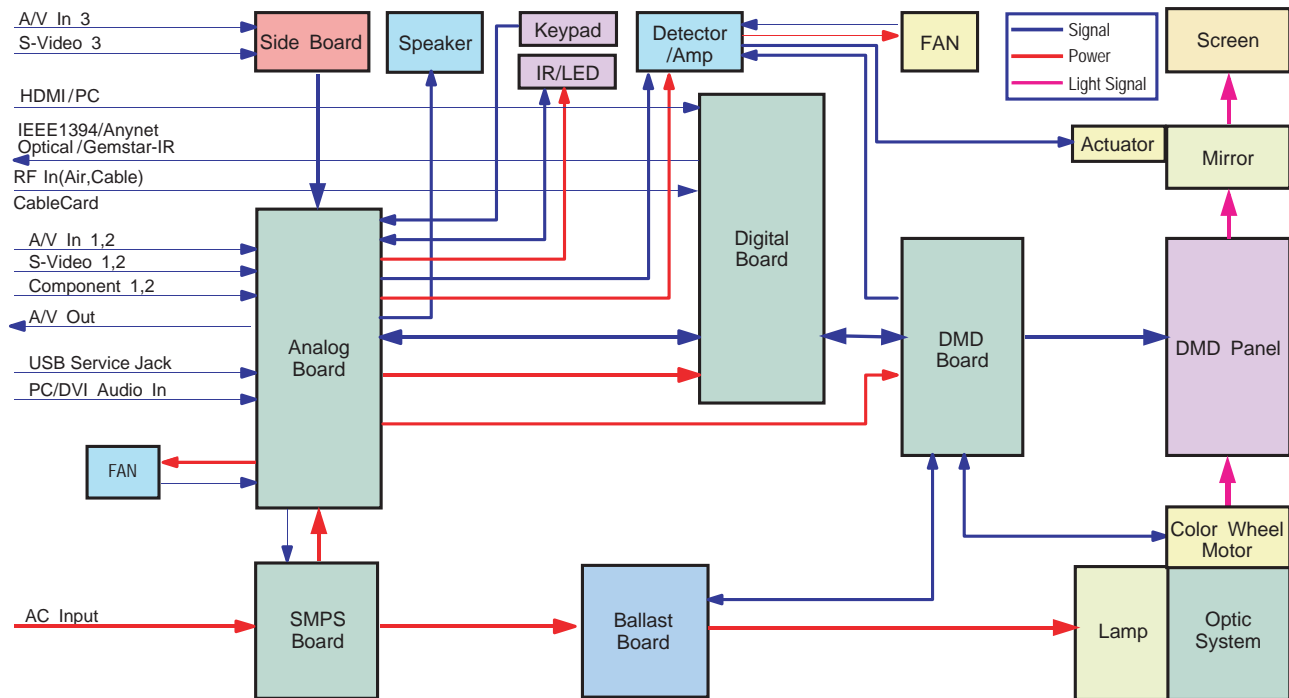

The DLP TV is largely divided into: Power part, Engine part and Analog + Digital parts.

The ass'y that consists of the DMD board, Detect (Actuator) board, lamp, ballast and optical devices is called the Engine.

The analog + digital board parts receive the AV signals to output voice signals and process the remote control signals.

The engine part displays the video data on the screen, which is generated in the analog + digital boards.

The AV signals are input through the analog and digital boards. ADV7401 processes the MUX and decoding while X226 B processes the CPU functions, MPEG and I2S.

Finally, the improved DNle image is sent to the DMD engine board.

The final data by DNle is processed in DDP1011 of the DMD board to display the image on the DMD panel. This image is created by the light of the lamp through the color wheel which is enlarged and projected onto the screen.

This is the DLP of the L3 or L6 type that the actuator operates additionally during this process.

The power terminal generates the DC power needed for the product and sends it to the analog board. The analog board supplies the power to the digital and DMD boards.

In the meantime, the power source board supplies DC220v - 400v directly to the ballast in order to light the lamp.

The ballast is like a stabilizer for lighting the lamp.

The ultimate purpose of the TV set is to project an image onto the screen and output the voice signals synchronized with the image. And based on the DMD panel used, a 1-panel TV requires a color wheel while a 3-panel TV does not. The HD4 panel needs an actuator while the HD2 does not. However, the drive mechanism and the overall block structure of the two panels are the same.

13-2 Partial Block Description

13-2-1 Power Board Block Description

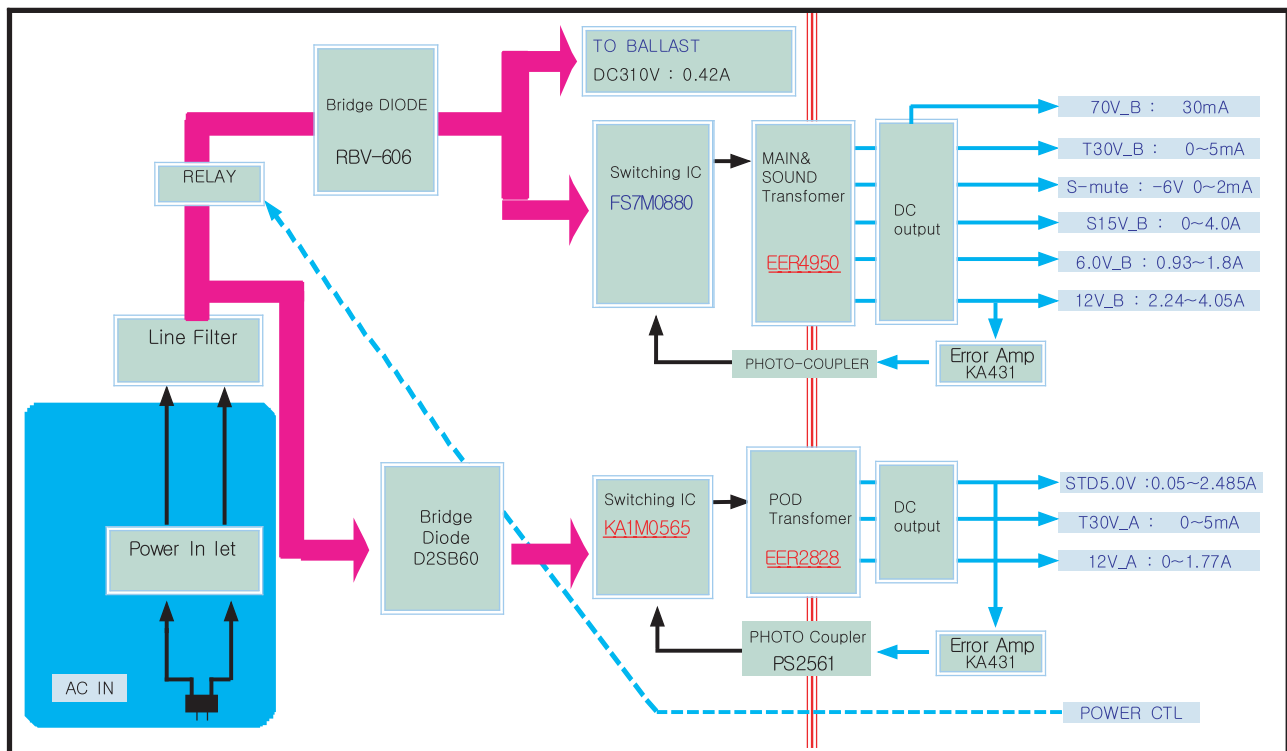

1. What is SMPS?

This is an acronym for Switching Mode Power Supply and this is responsible for receiving AC input voltage (Line frequency: 50HZ~60HZ) and supplying insulated DC output.

2. SMPS Components

- 1) Standby Power: A combination of ICS801 (SWITCHING IC) and TS801S (TRANS) that supplies STAND-BY 5V for operating the Micom.
- 2) Multi Power: The voltage supplied when the power is turned on.
It is a combination of IC801S and T801S that supplies various voltages including D12V, A6.5V, S14.5V, T30V and A65V.

3. SMPS Operation

- 1) SMPS System: Uses Fly-Back technology for both standby and multi power.
- 2) Operation: Fly-Back is one of the most popular power-supply systems and uses less power than 200W as well as being the cheapest of all multi output SMPS systems.

Let's have a look at how it operates...

- a. Converts AC input into DC (HOT) (rectifies to DS801 before smoothing to CS801)
- b. The converted DC voltage is high, especially compared to ground, so touching it will cause electric shock.
Use T801S (Trans) to insulate the secondary voltage and take advantage of the PWM operations of T801S and IC801S to induce it.
- c. The secondary induced voltage is 66KHz square wave power, which goes through the smoothing cap (CS822) to be generated in the standby 5V.
- d. Multi power also operates the same way.

4. Input&Output voltage

- 1) Input voltage
 - * America(AC120V) - OPTION
 - * Korea(AC220V) - OPTION
 - * The others(AC100V~AC240V) - OPTION
- 2) Output voltage
 - * D12V / 2.5A - 12V , 3.3V , 1.8V : For signal processing
 - * A6.5V / 1A - For driving the tuner
 - * S14.5V / 4A -For driving sound processor
 - * T30V / 5mA - For driving the tuner
 - * A65V / 30mA - For driving the actuator

13-2-2 Digital Board Block Description

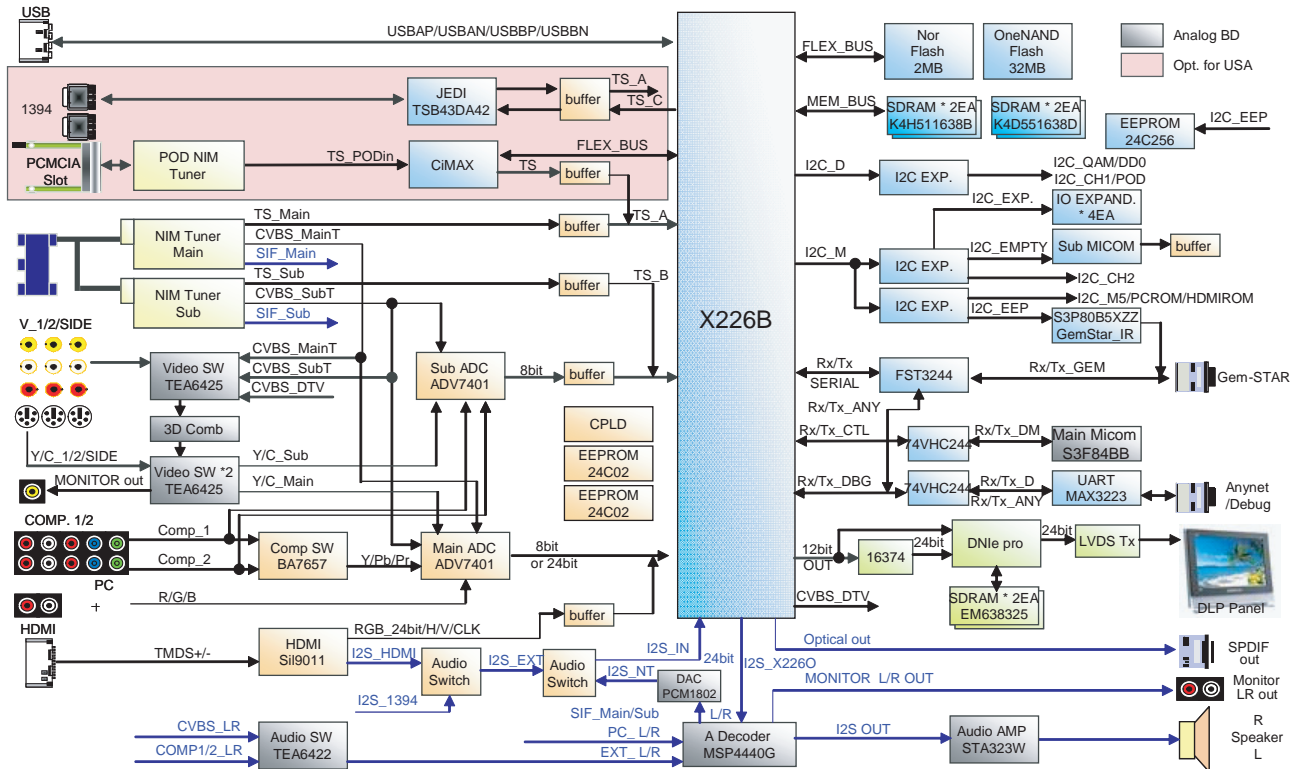

- ADV7401: Analog YPBPR, CVBS, Y/C(SUPER), Input MUXING and Video Decoding
- X226: CPU, + MPEG Decoder, Audio signals transferred to MSP of the analog board by I2S
- DNIE: Uses a noise-filtering and picture quality improvement algorithm to implement natural colors.
- Tuner: Two HD tuners, each taking the role of the analog tuner.
- HDMI: Receives one input signal and transfers it to X226 in 24 bits.
- Others: Anynet implementation, Optical Power Port, USB Update Port (not available for MP3)

The L3HD or L6HD digital board contains two HD tuners to implement analog as well as digital signals from air/cable broadcasting. It decodes Y PB PR CVBS, Y/C(SUPER) and HDMI inputs using ADV7400 and silicon chips, which are transferred to X226 (ATI), a combination of the main CPU and the MPEG decoder.

All video/audio inputs are transferred to X226 for digital processing and all video output goes through DNIE to the DLP DMD board.

Audio signals are transferred to the MSP chip of the analog board using I2S and are emitted through the speaker.

It also has an Anynet port, a 5.1 channel optical port and a USB port for a S/W update.

13-2-3 Analog Board Block Description

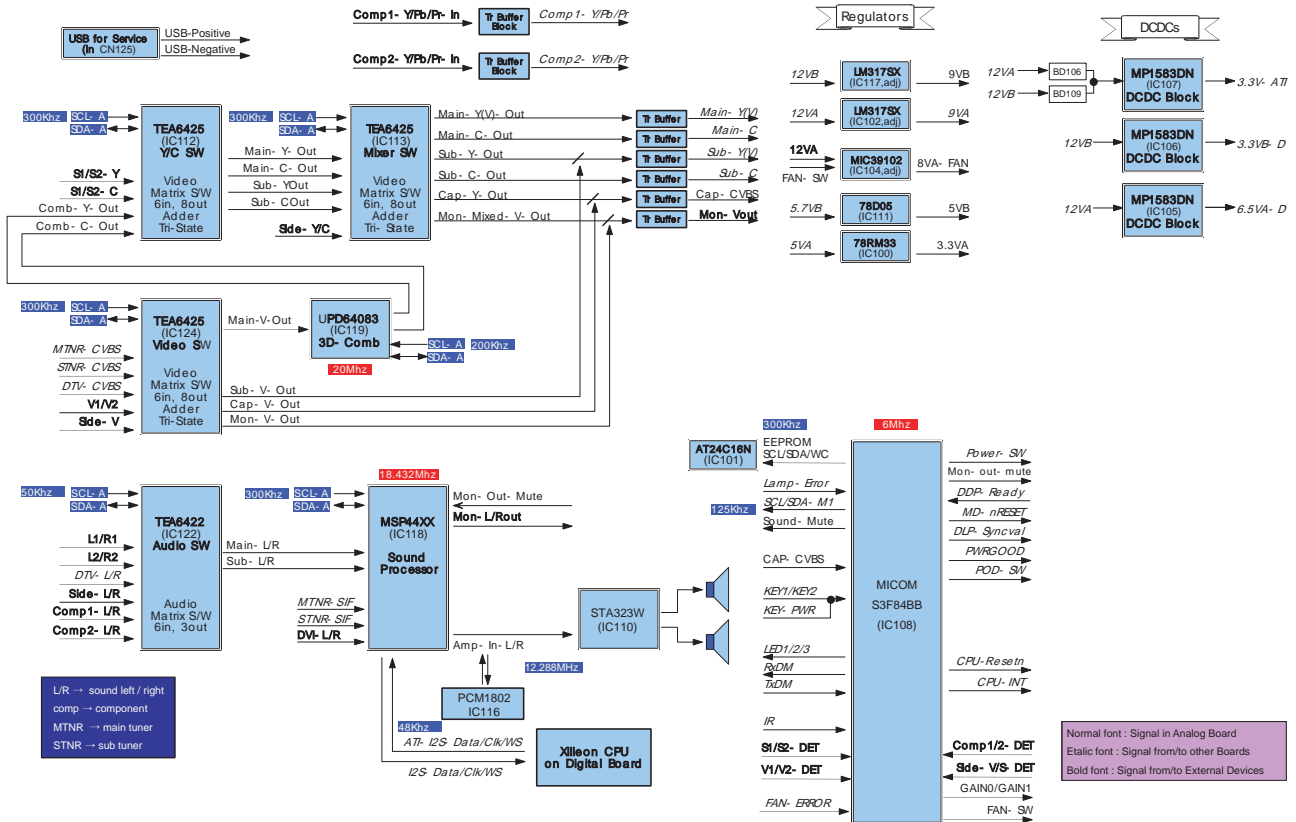

■ Analog Video Signal Processing

■ Select Sound/Video

One is selected from multiple inputs by the switching ID. MICOM decides which port is used for output. For broadcasting signals, sub-outputs are transferred in CVBS and, the main outputs in Y/C through the 3D Comb, to the digital board.

Sound signals are selected by the switching IC, of which only one input is transferred to the speaker.

■ Detection Signal Flow

When each port is connected to a signal cable, the detection signal is "low" and can be checked by Micom scanning.

13-2-4 DMD Board Block Description

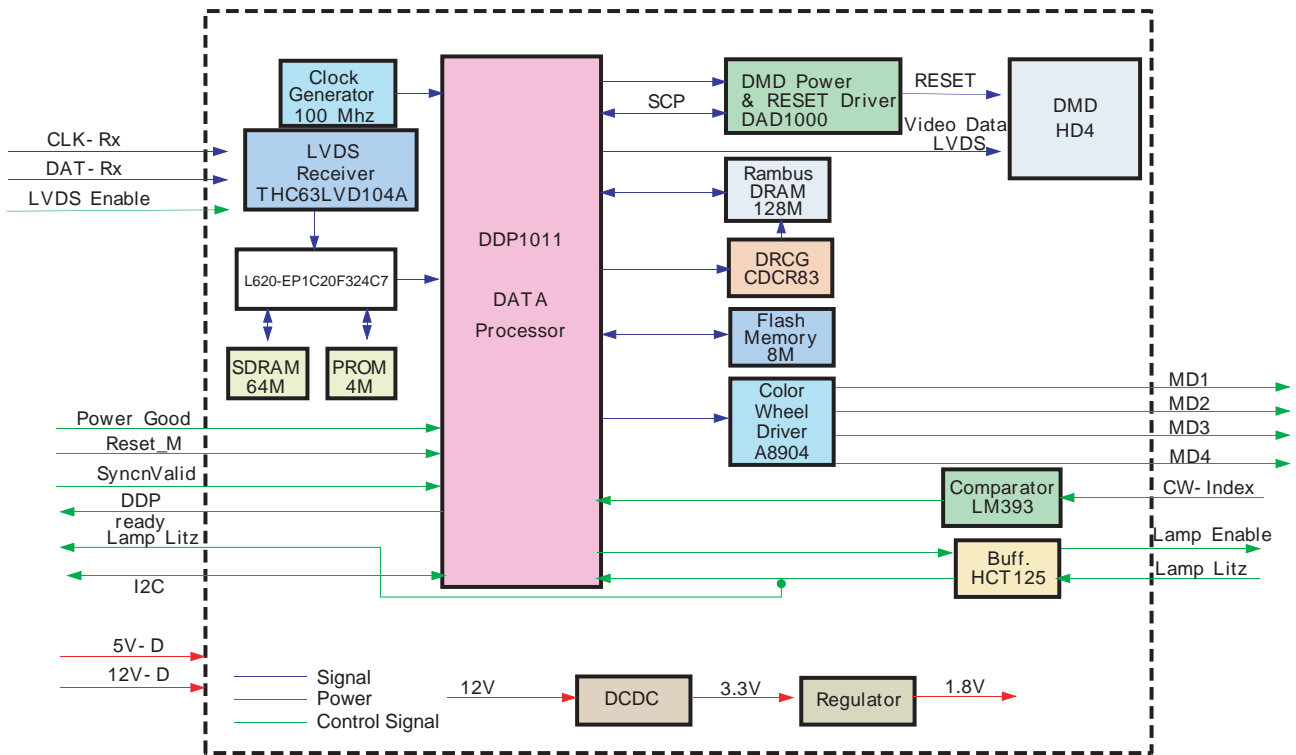

- Controls the lamp (ON/OFF)
- Drives the color wheel motor
- Drives the panel
- Controls the sensors

13-3 New Circuit Description

13-3-1 Output Voltage States of the DMD Board Parts

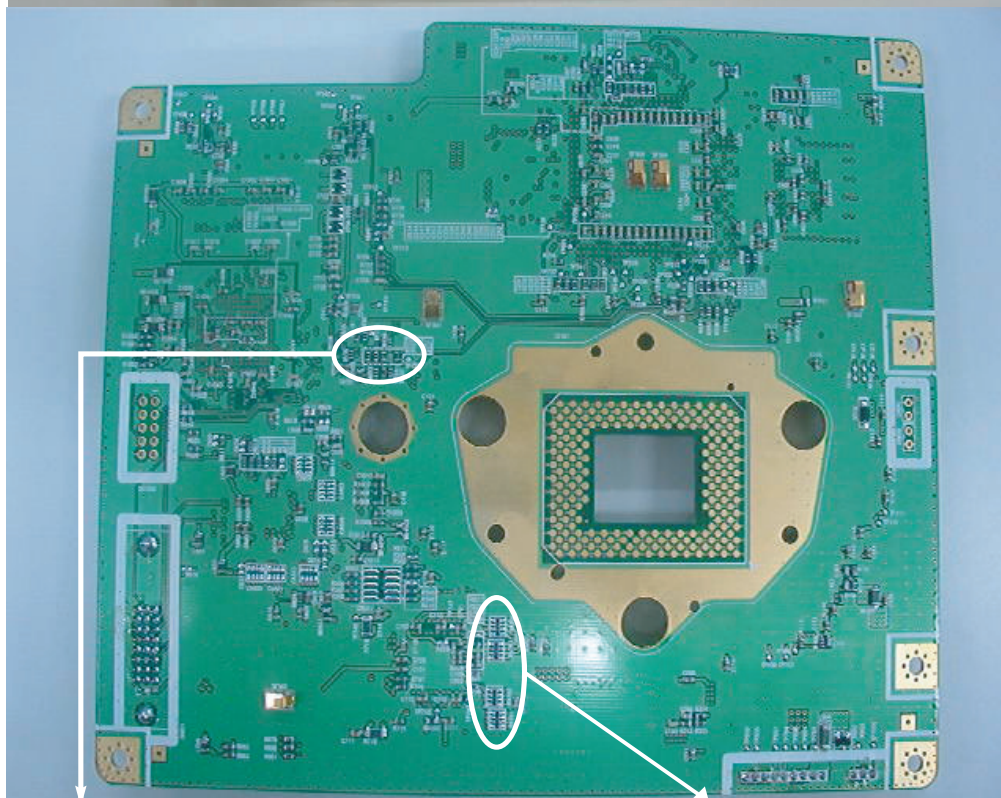
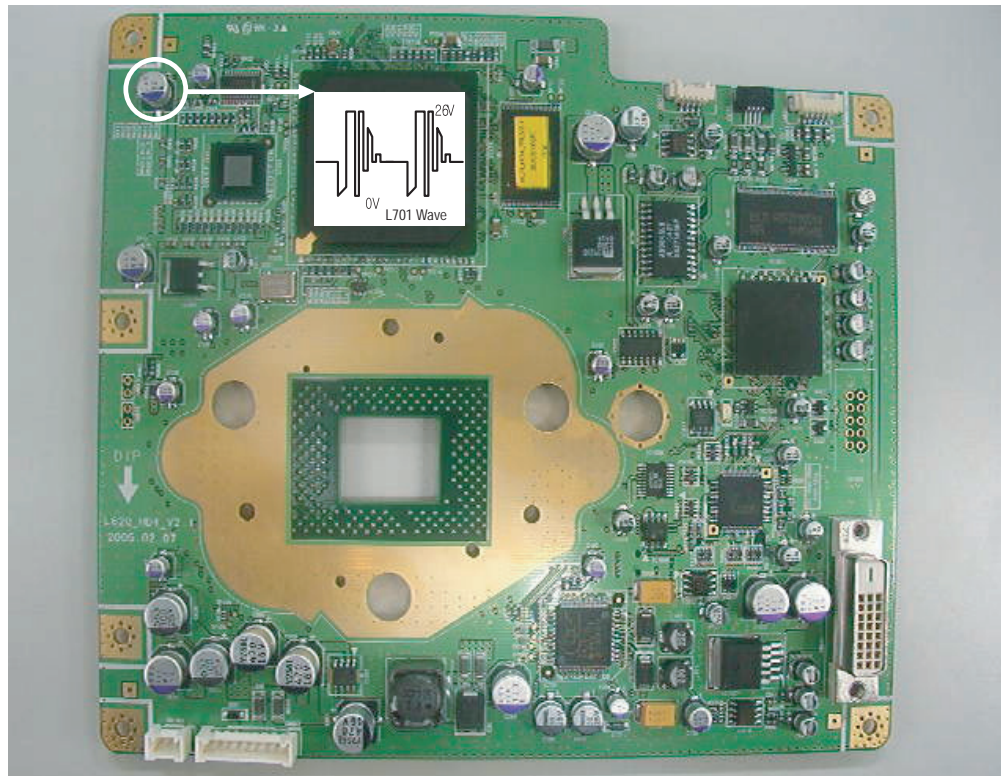

Loc.	Characteristics	
R534	LAMP EN	High from DDP1010
R531	LAMP LITZ	High (5V) before the lamp turns on. Low (0V) when the lamp turns on.

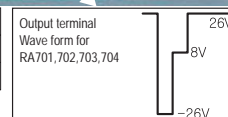

13-3-2 DMD Panel Pin Terminal Characteristics Diagram

※ Remove the heat sink attached to the DMD Board and tighten the screws in four places and then inspect the characteristics of each pin terminal.

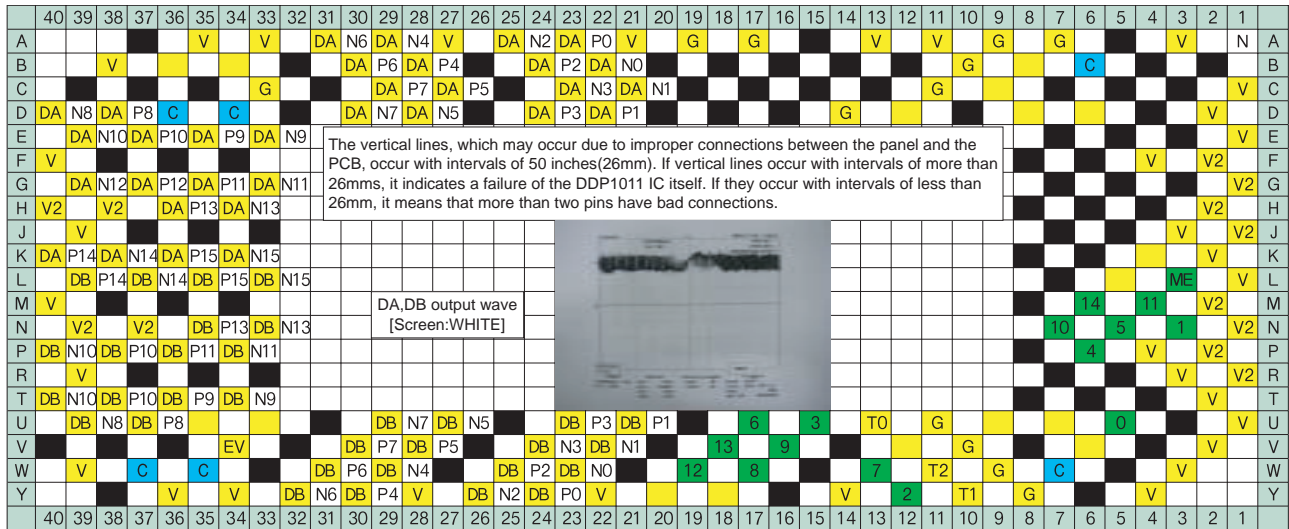

Pin Name	Description	Pin Name	Description
V	Voltage : 3.3V	T	Test Point
V2	VCC2 : 8V	ME	Mirror Bias Extra
DA	A Channel Data Bus [When measured, there should be a waveform]	C	Clock
DB	B Channel Data Bus [When measured, there should be a waveform]	P#	A,B Channel Positive
NO.	MBRST# (Mirror Bias Rest) 26V	N#	A,B Channel Negative
G	The part from the present position to the GND (The black part is also a GND.)		

13-3-3 Description of Terminal Characteristics

Pin Name	Description
SCTRL_BN/P	B channel LVDS serial control
DCLK_BN/P	B channel LVDS CLOCK
SCPDI	SERIAL CONTROL DATA INPUT
SCPDO	SERIAL CONTROL DATA OUTPUT
SCPENB	SERIAL CONTROL ENABLE
SCPCK	SERIAL CONTROL CLOCK
DMD RESETB	DMD LOGIC RESET
MBRST(14:0)	MIRROR BIAS RESET
MBRST_EXTRA	UNUSED MIRROR BIAS RESET
SCR_CLR	TEST CLEAR PINS(NORMAL GND)
READOUTA(1:0)	A-CHANNEL SERIAL DATA OUT DURING SPAM READ TEST OPERATION
READOUTB(1:0)	B-CHANNEL SERIAL DATA OUT DURING SPAM READ TEST OPERATION
TP(2:0)	MANUFACTURING TEST POINT(NO CONNECTED DURING NORMAL CPERATION)
RSV_A(4:0)/RSV_B(4:0)	RESERVED PINS(NORMAL:GND)
EVCC	REFERENCE VOLTAGE DURING SPAM READ TEST OPERATION(NORMAL GND)
VCC2	MIRROR ELECTRODE VOLTAGE(7.3V)
VCC	LOGIC SUPPLY
VSS	LOGIC GROUND

13-3-4 Engine Failure Inspection Flow Chart for the DMD Board

No.	Description	Key Point	Remark
1	1) When the power cord is plugged in, 2) DC 330V is automatically supplied to the ballast.	Check whether the DC 330V power is supplied to the ballast.	
2	1) When the power key is pressed via the remote control, the micom of the analog board outputs high (5V) PWR signals. 2) The power board operates normally. 5V and 12V are supplied to the DMD CN602 terminal.	Check whether 5V and 12V are supplied to the CN602 terminal.	* 12V must be supplied to operate the motor.
3	1) The MTR Reset signal is supplied to the TP713 terminal of the motor IC704 from the micom on the digital board and then the motor starts to drive. 2) If the color wheel rotates for a certain time and then stops, check whether the color wheel sensor is normal. (Check the waveform on the No.2 terminal below CN502.) 	After the set is powered on, check whether 5V is detected on pin No.20 of IC704. → After a while, the sound generated by the rotating color wheel is heard.	* If 5V is not detected, the motor will not operate.
4	1) Check whether the signal (SCI: START CONTROL INPUT) that turns on lamp #2 of CN504 on the DMD board is high (5V).	Check whether CN504 #2 signal is 5V.	* When SCI is high (5V), the lamp litz of CN504 is low (0V). * CN504 #2 terminal voltage changes to pulse wave form 14 seconds after (for 50 inch TV) the time that the voltage is 5V.
5	1) Method for checking whether the DDP1011 IC RESET is normal.	If the voltage R204 is 3V, it is normal.	* When about 4 seconds have passed after changing to pulse waveform, the screens are displayed on the set.

13-3-5 IC Line Up

1. Power Board

Items	Descriptions	Remarks
Main SMPS	FS7M0880, Fairchild	IC-PWM Controller ; Main Power
Stand-by SMPS [America]	KA1M0565, Fairchild	IC-PWM Controller ; Stand-by Power
Stand-by SMPS [Korea]	KA5M0165, Fairchild	IC-PWM Controller ; Stand-by Power

2. Digital Board

Items	Descriptions	Remarks
MPEG2 Decoder	X226B	CPU(MIPS), TS Demux, MPEG2 Decoder, Format converter, Deinterlacer, Scaler, USB
analog Decoder, ADC	ADV7401	Video Processor, ADC
HDMI Receiver	SiI9011	Digital Receiver for HDMI with HDCP
COMPONENT S/W	BA7657	COMPONENT S/W, H/V Sync S/W
Video Enhance	SDP32 SAMSUNG	RGB Processor
Program ROM	AT49BV x 2	32M(1M x 16) x 2, Nor-Type Flash Memory
Frame Buffer	192MB DDR, 64M ,Samsung	Frame Memory
LVDS Transmitter	THC63LVDM83R, THINE DTC34LM85A, DOESTEK	DTC34LM85A, DOESTEK
IEEE1394	JEDI(TSB43DA42A)	IEEE1394 Interface
Gemstar EPG	Yamu MICOM(3P80B5X)	IR Blaster

3. Analog Board

Items	Descriptions	Remarks
Video Switch	TEA6425, SGS-Thomson	Video Switch IC for TV *3
Audio Switch	TEA6422, SGS-Thomson	Audio Switch IC for TV
3D-Comb	uD64083, NEC	3 Dimensional Y/C Separation LSI
Sound Module	MSP4440, Micronas	Multistandard Sound Processor With TruSurround XT
Sound AMP	TPA3001D, TI	1 Channel Digital Audio Power Amplifier *2
Micom	SDA55xx, Micronas	Micro Controller

4. DMD Board

Items	Descriptions	Remarks
DMD Driver	DDP1011, TI	DLP Data Processor
Reset, Power	DAD1000, TI	DMD Power and Reset Driver
Motor Controller	A8904, Allegro	12V VCM/Spindle Pre-Driver
Frame Buffer	K4R271669, Samsung	128M(246K x 16 x 32B), Rambus DRAM
Clock Generator	CDCR83, TI	Direct Rambus Clock Generator
Program ROM	M29W800BT, ST	8M(1M x 8 or 512K x 16), Flash Memory
Actuator Driver	Cyclone, Altera	Frame Extractor 60Hz(1 frame) → 120Hz(1/2 frame)
LVDS Receiver	THC63LVD104, Thine	LVDS Digital Receiver, 75MHz

14. Reference Information

14-1 Other issues related to other products

Problem	Descriptions
A fixed screen can cause permanent damage to the TV Braun tube.	Braun, PDP and LCD TVs can all be damaged. When a still image is displayed in a sequence, this can leave stains or after-images due to the characteristics of the panel. However, the DLP TV has the advantage that no stains or after-images are left on the screen. The DLP TV has mirror pixels on the DMD panel that project the beam onto the screen, in which the mirror is a digital representation of 0s and 1s, leaving no trace of light. The mirror returns to a blank state so that no stains or after-images are left.
Confusion between the ANYNET Port and the SERVICE Jack Port	The SAMSUNG SKY500N model has both an ANYNET port and a SERVICE jack port. Because the shape of the ANYNET port on the DLP TV is the same as that of the SERVICE jack port of the SKY500N, it fails to turn the TV off after a connection has been reported. The ANYNET port uses an RS232 port called Phone Jack, and the SERVICE jack port also uses the RS232 port. However, you must not connect the SERVICE port and the ANYNET port. Check if the port is the ANYNET port or the SERVICE port before connecting the port. Even if the TV cannot be turned on after connecting, the TV will turn on if you disconnect the connection.
Length of DVI Cable / PC RGB Cable	<p>- A too long DVI cable may cause a malfunction or degradation of the visual quality due to an attenuation of the signal. There is no recommendation for the cable length at present. In general, although a cable length of up to 5 meters should work, please check if video is properly displayed on the screen after connecting. If you think the length of the cable is longer than for normal use, check the visual quality of the video on the screen and shorten the length, if necessary.</p> <p>- This also applies to the PC RGB (D-Sub) cable. When the length of the cable is longer than for normal use, video may not be displayed on the screen. In this case, shorten the cable length.</p>
When a digitally distributed TV user receives HD-rated broadcasts:	The digital distributed TV (Ready Technique) can render HD sources as HD-rated. However, you need to install a set-top box for this purpose. The digital TV alone cannot render HD broadcasting as HD-rated. Install the formal set-top box for HD broadcasts.
When a digital distributed TV user selects normal size (4:3) to receive SD-rated digital broadcasts:	The digitally distributed TV (Ready Technique) renders any broadcasting service as SD-rated. However, when connected to a set-top box, the digital TV renders HD broadcasts as HD-rated and renders SD as SD-rated. The screen size is scaled to 4:3.
When a digitally built-in TV user receives SD (air) broadcasting:	The digitally integrated TV ("built-in" type) renders SD broadcasting as SD-rated. This can be understood easily. Even a high-resolution TV cannot improve a low resolution picture into high quality. In contrast, an SD-rated TV cannot represent HD broadcasting as HD because the resolution of the TV is lower than the original.
When selecting a picture size of 4:3 in connection with a computer or a multimedia device:	The representation capability of SD or HD-rated depend entirely on the TV set. The HD TV can render HD broadcasting as HD-rated only when it receives HD sources. In the meantime, the HD TV renders SD as SD-rated when it receives SD sources. The picture size has nothing to do with the resolution; TV models like SVP-XXL3HD or SVP-XXL6HD have a size adjustment feature to 16:9, 4:3, Panorama, Zoom1, Zoom2 and Auto Wide. This is about the aspect ratio of the top and bottom boundaries to the overall screen and users can select their preference.

■ SD/HD broadcasts and the TV's display capability are related

1. A digital broadcast should be transmitted in wide screen (an aspect ratio of 16:9) HD. If the broadcasting station converts a conventional program created in normal screen (aspect ratio of 4:3) into a digital signal and broadcasts the signal, the left and right of the picture will not be displayed.

This symptom also appears in other manufacturer's TV's. The three appliance companies are trying to resolve the problem through the Ministry of Information and Communication.

- * When watching an SD (normal) broadcast through a Digital (Wide) TV (480P normal broadcast)
- * When watching an SD (normal) broadcast through a Digital Ready (Wide) TV (Using a set-top-box)
- * When watching an analog (normal) broadcast through a wide TV
(When watching a broadcast after changing the aspect ratio of the TV from 16:9 (wide screen) to 4:3)

2. When watching a DVD title or video tape in wide screen (21:9) through a wide (16:9) TV, watching video from a computer or game console by selecting the aspect ratio to 4:3, or watching video from a DVD, VCR, computer or game console through a wide TV by selecting the aspect ratio to normal (4:3) or wide (21:9), the left and right, or top and bottom of the picture will not be displayed.

This symptom appears in other manufacturer's TV's. The three appliance companies are trying to resolve the problem through the Ministry of Information and Communication.

■ Changing the Order of the Picture Size for 16:9 Display Devices

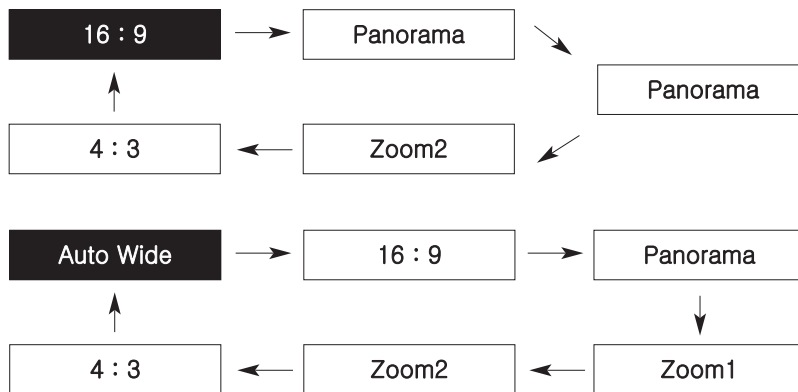

■ Changing the Order of the Picture Size for DTV 1080i/720p Sources



■ Restrictions

1. When you want to change the picture size in PIP 'ON', you must turn the PIP off before changing the size. However, you can change the main picture size even in PIP ON for products with no restrictions.
2. When the picture size is not Normal (4:3 for 4:3 display devices, 16:9 for 16:9 display devices) and you turn PIP on, the picture size is changed to Normal. However, you can turn PIP on without changing the picture size for products with no restrictions.
3. In the OSD notation for the picture size, 16:9 is represented as "Wide" instead of "16:9" for devices other than with 16:9 displays.
Ex: For LCD 15:9 devices, "Wide" is displayed on the OSD instead of "16:9".
4. The picture size can be changed even in the blue screen.
However, the picture size should be controlled by the product specifications if the change is impossible due to hardware restrictions.

14-2 Technical Terms

PIP (Picture In Picture)

A feature to enable two video images being displayed on one screen at the same time. For instance, you can see the TV channel and the video image at the same time.

Digital Broadcasting

The ATSC (Advanced Television Systems Committee) signals that the station digitalizes before transferring the audio/video signals.

Mono

A sound system that transmits voice signals in only one channel. It is hard to experience a 3D effect but can be run with one speaker.

LNA (Low Noise Amplifier)

This uses satellite technologies to amplify weak signals for improved quality even in poor reception areas.

Stereo

A sound system that transmits voice signals in two channels. This implements 3D effects by transmitting to both speakers (left/right).

Analog Broadcasting

The conventional system in which the station transfers the audio/video signals in NTSC formats.

Antenna Terminal

A terminal which the TV antenna is connected to. A round coaxial cable is connected to this terminal, which is usually used to watch air broadcasts.

English Captions (Subtitle)

A feature to provide English captions or character information services, which the user can use to study English using AFKN broadcasting or video tapes marked with "CC".

Audio/Video Terminal

The old 3- or 4-channel TV with no AV terminal has a low quality issue for video tape. The problem can be resolved using an A/V terminal that separates the audio and video signals. The video terminal is in yellow; the audio terminal is divided in two, white for left and red for right.

External Source

This includes sources from the video recorder, DTV set-top box and DVD player, (anything but the TV).

DVI-I Cable

One of the DVI cables that can transfer both digital and analog signals.

Satellite Broadcasting

This uses a satellite system to support a maximum of 100 channels including air services and provides high quality pictures anywhere in the country, even in poor reception areas. A set-top box (unbundled) is required to watch satellite broadcasting.

Closed Broadcasting

Other than VHF and UHF, this includes movies, entertainment and educational programs broadcast by hotels or schools. This is different from cable broadcasting.

Multiplexing

Two languages are provided at the same time when broadcasting foreign movies, dramas and news programs. You can choose either a native or foreign language, or choose both at the same time.

Component Terminal (Green, Blue, Red)

This provides maximum quality by dividing the contrast signals before transferring.

Cable Broadcasting

Compared to air broadcasting, it uses the cable system to transfer the signals. You should subscribe to a local cable broadcasting company and install a separate receiver.

Tuner

A device used to select a particular frequency from the TV set or the radio receiver.

Anynet

An AV networking system of Samsung's various AV devices, which enables the user to conveniently control AV devices using the TV.

DVD (Digital Versatile Disc)

This is a CD-sized, high storage disk that can store multimedia data including videos, games and audio applications using MPEG-2 compression technology.

DVI (Digital Visual Interface) Terminal

This is a digital signaling standard.

This uses TMDS to reduce the signal loss rate for sharper images.

DVI-D Cable

One of the DVI cables that can only transfer digital signals.

HDMI (High Definition Multimedia Interface)

An interface into which the digital signals as well as the high quality image data can be connected with one cable. There is no need to compress the bit rate.

S-video Terminal

This is, called "Super-video", divided into video and color signals for sharper image display.

VHF/UHF

VHF refers to the 2 - 13 channel system; UHF indicates the 14 - 69 channel system.